

The product accompanying this document has been guaranteed a California Air Resources Board (ARB) exemption, an "EO" number, or is a direct or consolidated replacement part. It is 50-state legal, per the manufacturer's application guide.

designation is:  **COLOR CODE GREEN**

The product for which this document was issued is emission-sensitive and is subject to certain federal and state regulations; the manufacturer has assigned an identification color code designating its intended use.

### Jet Powertech Performance Product

*The information shown below is provided for future reference*

Place this card in the glove box along with the vehicle registration and/or warranty



### WHAT TO DO BEFORE TAKING YOUR VEHICLE IN FOR SERVICE

If a problem occurs that may require you to take your vehicle to a mechanic or dealership for service, first remove the JET Performance Chip or Module and reinstall back to stock. If the problem disappears when you remove the JET Performance Product, call JET and we will troubleshoot the product. However, if returning to stock does **not** cure your problem, there is nothing wrong with your JET Performance Product and you will need to have your vehicle serviced.

**Anytime** a diagnostic machine is to be used, the vehicle must be back to stock. Diagnostic machines expect to find the original stock program and often cannot correctly analyze the problem if other devices are installed. Failure to reinstall your system back to stock can result in unnecessary and costly repairs not covered by JET. Before you have any work done on the vehicle that you feel may have been related to the JET Performance Chip or Module, please call JET at 714-848-5515.

### Limited Warranty

JET Performance Products warrants Chips and Modules to be free from defects in material and workmanship under normal use and if properly installed. This limited lifetime warranty is to the original purchaser for as long as he or she owns the vehicle on which the product was originally installed, provided all information requested is furnished. If found to be defective as mentioned above, it will be replaced or repaired at the sole discretion of JET if returned prepaid along with proof of date of purchase.

All other products and services performed by JET are warranted in defects in material and workmanship for a period of 6 months from date of purchase. This warranty is to the original purchaser for as long as he or she owns the vehicle on which the product was originally installed. Repair, Replacement, or Credit will be based on the date of purchase. Costs for labor are specifically excluded and are the sole responsibility of the purchaser.

This warranty does not apply to Custom Programming or any product incorrectly installed, modified by the purchaser, or to any product that has been subjected to misuse, negligence or accident.

To obtain warranty service and Return Authorization Number, contact our Customer Service Department at 714-848-5515 between 8 am and 5 pm Pacific Standard Time, Monday through Friday.

Defective Products may be brought or sent prepaid (with Return Number) to JET Performance Products, 17491 Apex Circle, Huntington Beach, CA 92647.

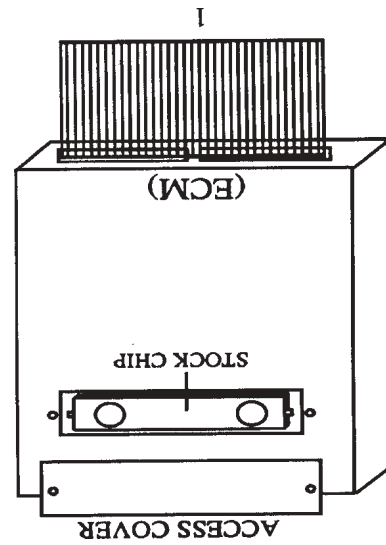

2. Remove the access cover located on the top of the ECM and remove the stock chip.

1. Locate ECM (see the location chart on page ) and remove the mounting screws and unplugging the ECM wiring harness. It is not necessary to unplug the battery.

## Installation Instructions Jet 6-PAK chip (Memcal)



## 6-PAK Installation Instructions

**Technical (714) 848-5515**

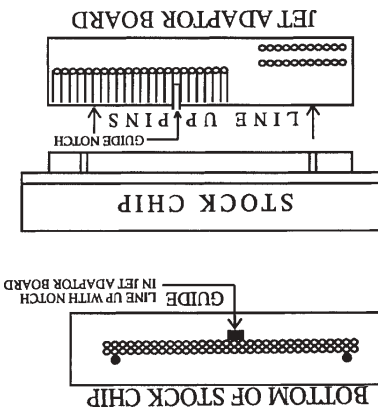

4. To assemble the 6-PAK, line up the notch in the JET Memcal adapter with the guide on the stock chip and push the chip on to the pins of the adapter.

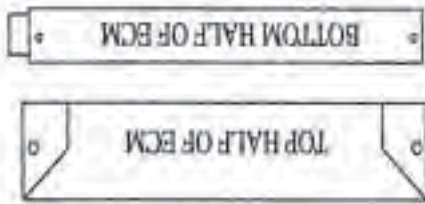

3. In some cases, it is necessary to remove the top half of the ECM to install the 6-PAK chip. To do this, remove all the external screws that hold the ECM together (most have 6 to 9 screws) and remove the top half of the ECM.

E.C.M. LOCATION CHART	
1-Behind Passenger Kick Panel	7-Passenger Side-Under Hood
2-Under Dash (passenger side)	6-Drivers Side Under Hood
3-Behind Glove Compartment	5-Behind Drivers Seat (next to battery)
4-In Center Console	

## INSTALLATION INSTRUCTIONS POWERTECH 24 PIN 6-PAK CHIP

1. Lower ECM (see location chart, remove mounting screws and remove ECM wiring harness.
2. Remove the access cover located on the top of the ECM and remove the stock chip.
3. Position the 6-PAK over the access cover, lining up the pins with the socket (be careful not to bend the pins). It is sometimes easier to install at a slight angle to spread the pins apart in the socket.
4. Install supplied screws to retain the 6-PAK, tighten them evenly and just snug them down.
5. Mount the switch box in a convenient location (usually in the glove box or under the dash) with the self tapping screws supplied with the kit, and connect the wire harness to the 6-PAK chip.
6. Reinstall the ECM in the original location.

### CHEVROLET

YEAR	MODEL	CHART#
1983-1994	Astro Van	1
1981	Camaro	4
1982-1994	Camaro	2
1993	Camaro	7
1981-1982	Corvette	5
1984-1990	Corvette	2
1984-1995	5 C/K 10,20,30	3
1982-1988	Monte Carlo	1
1984-1994	S10/GMC S15	2
1991-1994	Corvette	6
1988-1994	Beretta	1
1986-1994	Cavalier	3

### PONTIAC

YEAR	MODEL	CHART #
1981	Firebird	4
1982-1993	Firebird	2
1988-1991	Grand Prix	1

### OLDSMOBILE & BUICK

YEAR	MODEL	CHART #
1983-1987	Regal	1
1983-1989	Cutlass	1