



Equipped with AEM® Dryflow™ Filter
No Oil Required!

INSTALLATION INSTRUCTIONS

PART NUMBER:22-433

2004-2005	MITSUBISHI	Eclipse	Manual Trans.	L4-2.4L	SEE * NOTE
2000-2003	MITSUBISHI	Eclipse	Manual Trans.	L4-2.4L	C.A.R.B. E.O. # D-670

* **NOTE:** Legal in California only for racing vehicles which may never be used upon a highway

PARTS LIST

Description	Qty.	Part Number
Element Parts Kit 2.75 X 5" Dry Ele.	1	21-202DK
Short Pipe	1	2-4331
Adapter, MAF Mitsu.	1	2-606
Elbow, 2.75" 90 Degree	1	30217
Hose, Adapter 2.50/3.0" X3"	1	5-253
Mount, Rubber 1" X 6mm	1	1228599
Hose; 3/8"ID X 7"L	1	5-1007
Bracket, Support	1	32-3030
Bolt, Socket M6-1 X 30mm	4	1-2020
Bolt, Hex M6 X 1.0 X 16mm	1	1-2030
Washer, 6mm Soft Mount	2	559999
Nut, M6 Hex Serrated	5	444.460.04
Hose Clamp, 3/4"	2	4093-5
1/2" Bnd. Hose Clamp, 2.31-3.25"	3	9444
1/2" Bnd. Hose Clamp, 2.90"-3.75"	1	9452
1/2" Bnd. Hose Clamp, 2.56"-3.50"	1	9448

Read and understand these instructions **BEFORE** attempting to install this product. Failure to follow installation instructions and not using the provided hardware may damage the intake tube, throttle body and engine.

The AEM® intake system is a performance product that can be used safely during mild weather conditions. During harsh and inclement weather conditions, you must return your vehicle to stock OEM air box and intake tract configuration. Failure to follow these instructions will void your warranty.

1. Preparing Vehicle

- a. Make sure vehicle is parked on level surface.
- b. Set parking brake.
- c. If engine has run in the past two hours, let it cool down.
- d. Disconnect negative battery terminal.
- e. Do not discard stock components after removal of the factory system.

2. Removal of stock system



a. Factory air box system installed.



b. Pull breather hose off of valve cover. Loosen the upper and lower hose clamps on the stock inlet tube.



c. Unplug the MAF sensor. Remove stock inlet pipe. Release four clamps on the air box and remove upper air box from the vehicle.

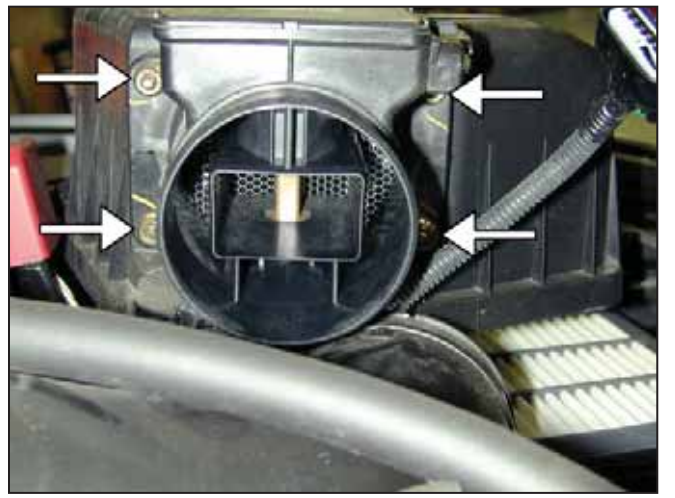

d. Loosen the four nuts that hold the MAF sensor to the airbox. Carefully set aside the MAF sensor.



e. Release air snorkel by first pressing in the centers of the plastic rivets.

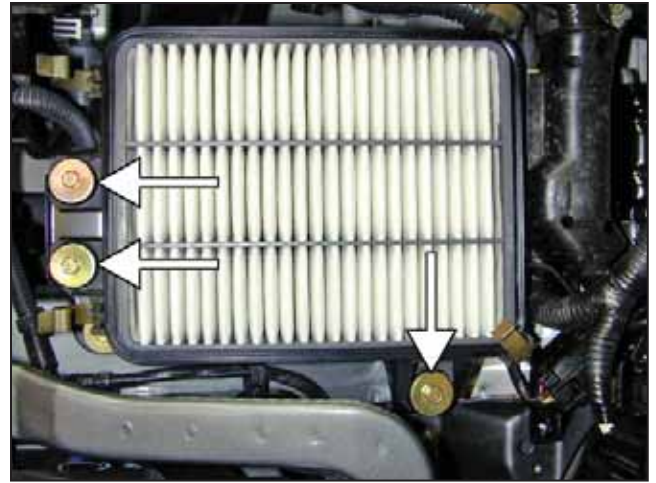

f. Loosen the three bolts holding down the air box. Remove air box and snorkel from vehicle.

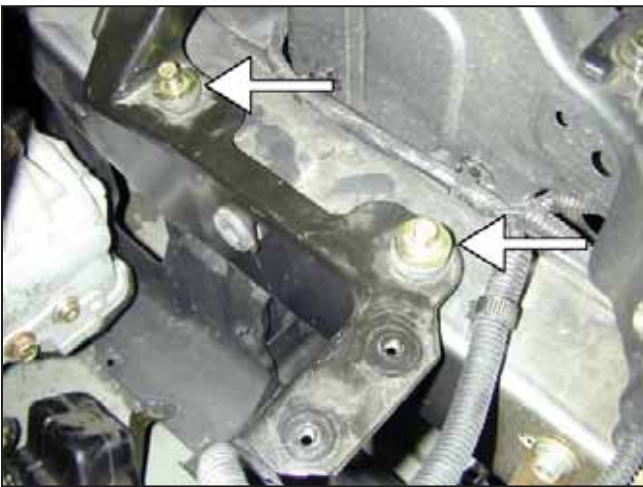

g. Remove lower mounting bracket.



h. Loosen the three bolts that hold in the lower air box and remove it from the vehicle.

3. Installation of AEM® intake system.

a. When installing the intake system, do not completely tighten the hose clamps or mounting hardware until instructed to do so.



b. Attach MAF adapter to MAF sensor using the supplied bolts and lock nuts.



c. Attach rubber reducer to MAF sensor using the size 52 hose clamp.



d. Place rubber elbow with two hose clamps onto the throttle body. The long end attaches to the throttle body.



e. Insert upper inlet pipe into rubber elbow. Attach support bracket to engine using the supplied bolt and washer. Place aluminum tab behind the plastic tab.

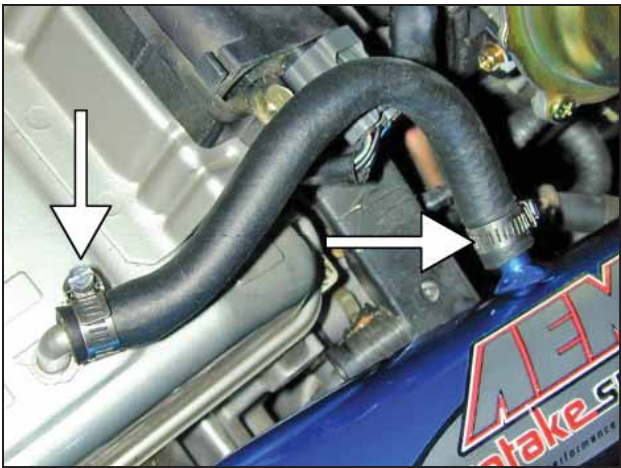

f. Install the supplied breather hose as shown. Secure both ends with supplied 3/4" hose clamps.



g. Install rubber mount in threaded hole as shown.



h. Install the air filter on to the MAF sensor adapter. Tighten the air filter hose clamp.



i. Install the MAF sensor assembly to the inlet pipe with a hose clamp. Attach support bracket as shown (See diagram for proper installation). Do not completely tighten the lock nut. Plug in the MAF sensor.

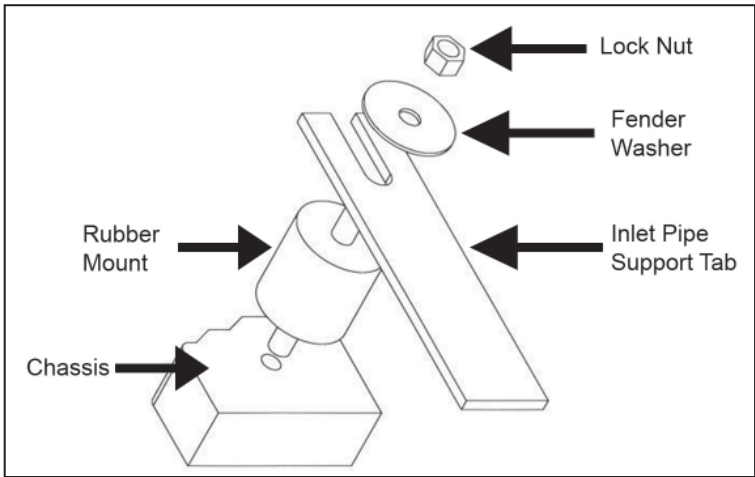

Proper rubber mount installation



AEM® intake system installed

4. Reassemble Vehicle

- a. Position the inlet pipes for the best fitment. Be sure that the pipes or any other components do not contact any part of the vehicle. Tighten the rubber mount, all bolts, and hose clamps.
- b. Check for proper hood clearance. Re-adjust pipes if necessary and re-tighten them.
- c. Inspect the engine bay for any loose tools and check that all fasteners that were moved or removed are properly tightened.
- d. Reconnect negative battery terminals and start engine. Let the vehicle idle for 3 minutes. Perform a final inspection before driving the vehicle.

5. CARB Sticker Placement

- a. The C.A.R.B. exemption sticker, (attached), must be visible under the hood so that an emissions inspector can see it when the vehicle is required to be tested for emissions. California requires testing every two years, other states may vary.

6. Service and Maintenance

- a. It is recommended that you service your AEM® Dryflow™ filter every 20,000 miles for optimum performance. Use AEM Dryflow cleaning kit part # 21-110.
- b. Use aluminum polish to clean your polished AEM® intake tube.
- c. Use window cleaner to clean your powder coated AEM® intake tube. **(NOTE: DO NOT USE aluminum polish on powder coated AEM intake tubes).**

For technical inquiries
e-mail us at
sales@aemintakes.com
or
call us at
800.992.3000

AEM Air Intake System Warranty Policy

AEM® warrants that its intake systems will last for the life of your vehicle. AEM will not honor this warranty due to mechanical damage (i.e. improper installation or fitment), damage from misuse, accidents or flying debris. AEM will not warrant its powder coating if the finish has been cleaned with a hydrocarbon-based solvent. The powder coating should only be cleaned with a mild soap and water solution. Proof of purchase of both the vehicle and AEM intake system is required for redemption of a warranty claim.

This warranty is limited to the repair or replacement of the AEM part. In no event shall this warranty exceed the original purchase price of the AEM part nor shall AEM be responsible for special, incidental or consequential damages or cost incurred due to the failure of this product. Warranty claims to AEM must be transportation prepaid and accompanied with dated proof of purchase. This warranty applies only to the original purchaser of product and is nontransferable. Improper use or installation, use for racing, accident, abuse, unauthorized repairs or alterations voids this warranty. AEM disclaims any liability for consequential damages due to breach of any written or implied warranty on all products manufactured by AEM. Warranty returns will only be accepted by AEM when accompanied by a valid Return Merchandise Authorization (RMA) number. Credit for defective products will be issued pending inspection. Product must be received by AEM within 30 days of the date RMA is issued.

If you have a warranty issue, please call (800) 992-3000 and our customer service department will assist you. A proof of purchase is required for all AEM warranty claims.