



INTAKE SYSTEMS FOR VEHICLES LISTED ARE 50 STATE LEGAL. SEE KNFILTERS.COM FOR CARB STATUS ON EACH PART FOR A SPECIFIC VEHICLE.

# INSTALLATION INSTRUCTIONS

**57-9038**  
**LEXUS**  
**2015-17 RC-F**  
**V8-5.0L**

**TOOLS NEEDED:**  
 Flat Blade Screw Driver  
 Phillips Screw driver  
 3/4" wrench

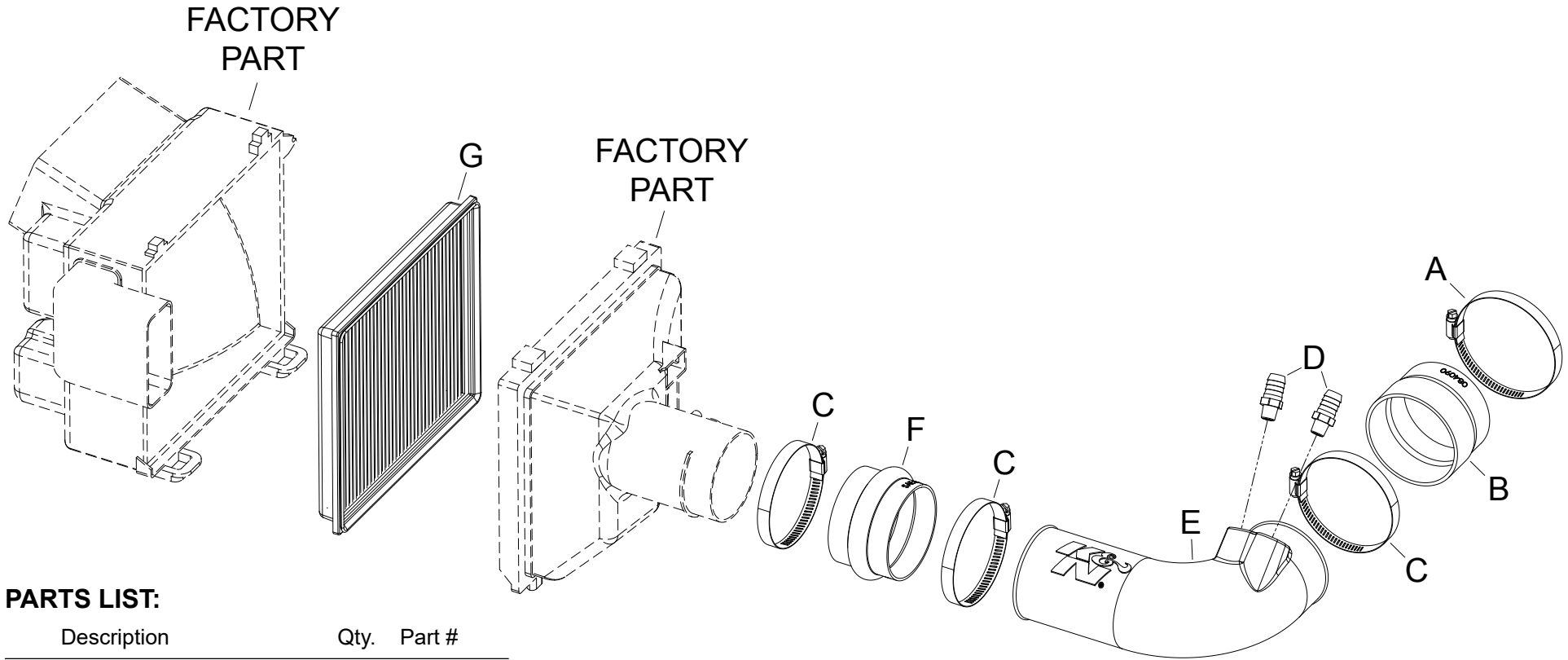

**PARTS LIST:**

Description	Qty.	Part #
A HOSE CLAMP #60 STAINLESS	1	08628
B HOSE; 3-5/8" TO 3-1/2" ID	1	084090
C HOSE CLAMP #56	3	08620
D VENT; STRT, 5/8 BARBED 1/4	2	08911-1
E INTAKE TUBE (KK)	1	087307A
F HOSE; 3-1/2" ID X 2-1/2" L	1	08699
G FILTER	1	33-2453

**If you need any assistance please call 1-800-858-3333 to speak with a representative in our Customer Service Center before returning the product.**

**NOTE: FAILURE TO FOLLOW INSTALLATION INSTRUCTIONS AND NOT USING THE PROVIDED HARDWARE MAY DAMAGE THE INTAKE TUBE, THROTTLE BODY AND ENGINE.**

**TO START:**

1. Turn off the ignition and disconnect the negative battery cable.  
**NOTE: Disconnecting the negative battery cable erases pre-programmed electronic memories. Write down all memory settings before disconnecting the negative battery cable. Some radios will require an anti-theft code to be entered after the battery is reconnected. The anti-theft code is typically supplied with your owner's manual. In the event your vehicles anti-theft code cannot be recovered, contact an authorized dealership to obtain your vehicles anti-theft code.**



2. Release the spring clamps securing the crank case breather hoses and then disconnect the hoses from the intake tube.

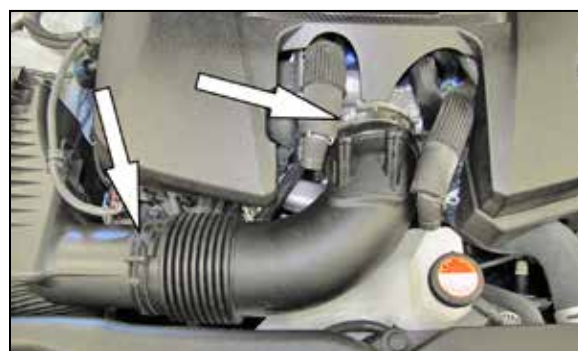

3. Loosen the hose clamps that secure the intake tube to the throttle body and air filter housing and then remove the intake tube from the vehicle.  
**NOTE: K&N Engineering, Inc., recommends that customers do not discard factory air intake.**

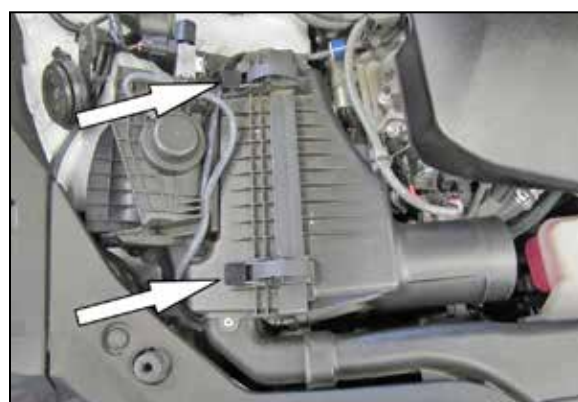

4. Release the two clips retaining the clean side of the filter housing.



5. Place the housing up out of the way and remove the stock air filter from the lower housing.



6. Install the K&N® air filter and then resecure the clean side housing.

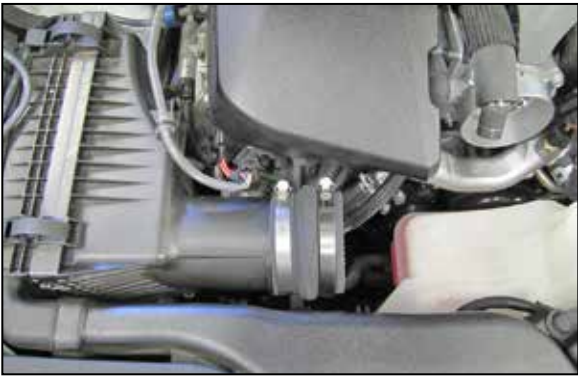

7. Install the coupling hose (08699) onto the air filter housing and secure with the provided hose clamp.



8. Install the coupling hose (084090) onto the throttle body and secure with the provided hose clamp.



9. Install the provided vent fittings into the K&N® intake tube as shown.

**NOTE: Plastic NPT fittings are easy to cross thread. Install the vent fitting "hand" tight, then turn it two complete turns with a wrench.**



10. Install the K&N® intake tube assembly into the coupler at the air filter housing and then into the coupler at the throttle body. Adjust the tube for best fit and then secure with the provided hose clamps.

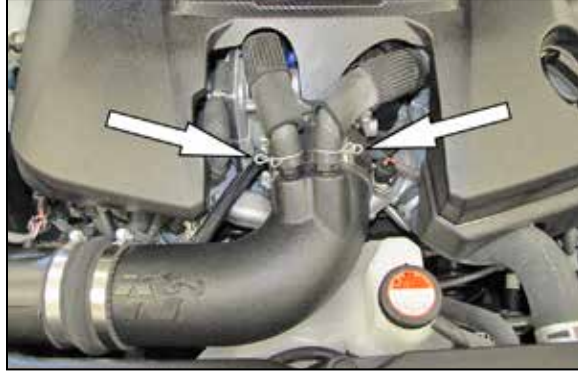

11. Install the crank case breather hoses and then secure with the factory spring clamps.



12. Reconnect the vehicle's negative battery cable. Double check to make sure everything is tight and properly positioned before starting the vehicle.

13. The C.A.R.B. exemption sticker, (attached), must be visible under the hood so that an emissions inspector can see it when the vehicle is required to be tested for emissions. California requires testing every two years, other states may vary.

14. It will be necessary for all K&N® high flow intake systems to be checked periodically for realignment, clearance and tightening of all connections. Failure to follow the above instructions or proper maintenance may void warranty.

#### ROAD TESTING:

1. Start the engine with the transmission in neutral or park, and the parking brake engaged. Listen for air leaks or odd noises. For air leaks secure hoses and connections. For odd noises, find cause and repair before proceeding. This kit will function identically to the factory system except for being louder and much more responsive.

2. Test drive the vehicle. Listen for odd noises or rattles and fix as necessary.

3. If road test is fine, you can now enjoy the added power and performance from your kit.

4. K&N Engineering, Inc., requires cleaning the intake system's air filter element every 100,000 miles. When used in dusty or off-road environments, our filters will require cleaning more often. We recommend that you visually inspect your filter once every 25,000 miles to determine if the screen is still visible. When the screen is no longer visible some place on the filter element, it is time to clean it. To clean and re-oil, purchase our filter Recharger® service kit, part number 99-5050 or 99-5000 and follow the easy instructions.

**INTAKE SYSTEMS FOR VEHICLES LISTED ARE 50 STATE LEGAL. SEE KNFILTERS.COM FOR CARB STATUS ON EACH PART FOR A SPECIFIC VEHICLE.**



# HORSEPOWER GUARANTEED

**THIS KIT IS GUARANTEED TO INCREASE HORSEPOWER**

Every Intake Kit we sell has been tested on a Dynamometer and proven to increase horsepower. We measure horsepower at the wheels. The horsepower rating that may have been on the window sticker when your car was new is a measurement of horsepower at the engine and there is often a loss of horsepower through the drive train by the time it reaches the wheels.

K&N hereby warrants and guaranties to the original retail purchaser of any K&N air intake kit that the vehicle on which the air intake system is installed will gain an increase in horsepower, or K&N will refund the purchase price, including sales tax, to the retail purchaser, subject to the following terms and conditions:

The K&N air intake system must have been properly installed on the vehicle in accordance with the included K&N instructions. The system must be the correct part number for the vehicle upon which it was installed. The vehicle must be in good running condition. The vehicle must undergo a dynamometer test both before and after the installation of the system, with no changes to the vehicle, except for the installation of the kit. The dyno tests must be performed by the same testing facility and must be performed within 30 days of one another and within 60 days of the date of purchase. The test results or work order for each test must reflect the name and address of the vehicle owner or operator having the test performed; the year, make, model, and mileage of the vehicle being tested; and the horsepower results from both tests.

If the dyno tests show that the vehicle did not gain an increase in horsepower, then the retail purchaser must return the complete air intake system to K&N in its original packaging, together with his or her proof of purchase, the ORIGINALS of the two dyno tests statement requesting a refund in accordance with our Horsepower Guarantee. Upon receipt of all of the foregoing, K&N will refund the full purchase price, including sales tax, to the original retail purchaser. This guaranty does not apply to any other costs incurred by the purchase, including, but not limited to, the dyno tests, parts and labor for the installation and removal of the air intake system, shipping costs, rental car, loss of use or incidental damages, if any, and K&N expressly disclaims any and all liability for same.