



# AIRCHARGER®

## HIGH-FLOW INTAKE KITS

NOT LEGAL FOR SALE OR USE ON ANY POLLUTION CONTROLLED MOTOR VEHICLE IN CALIFORNIA OR STATES ADOPTING CALIFORNIA EMISSION PROCEDURES.  
See knfilters.com for CARB status on each part for a specific vehicle

### INSTALLATION INSTRUCTIONS

## 63-2515

### FORD

### 2020-21 MUSTANG SHELBY GT500

### V8-5.2L SuperCharged

#### TOOLS NEEDED:

- Ratchet
- Extension
- 10mm socket
- 13mm socket
- flat blade screw driver

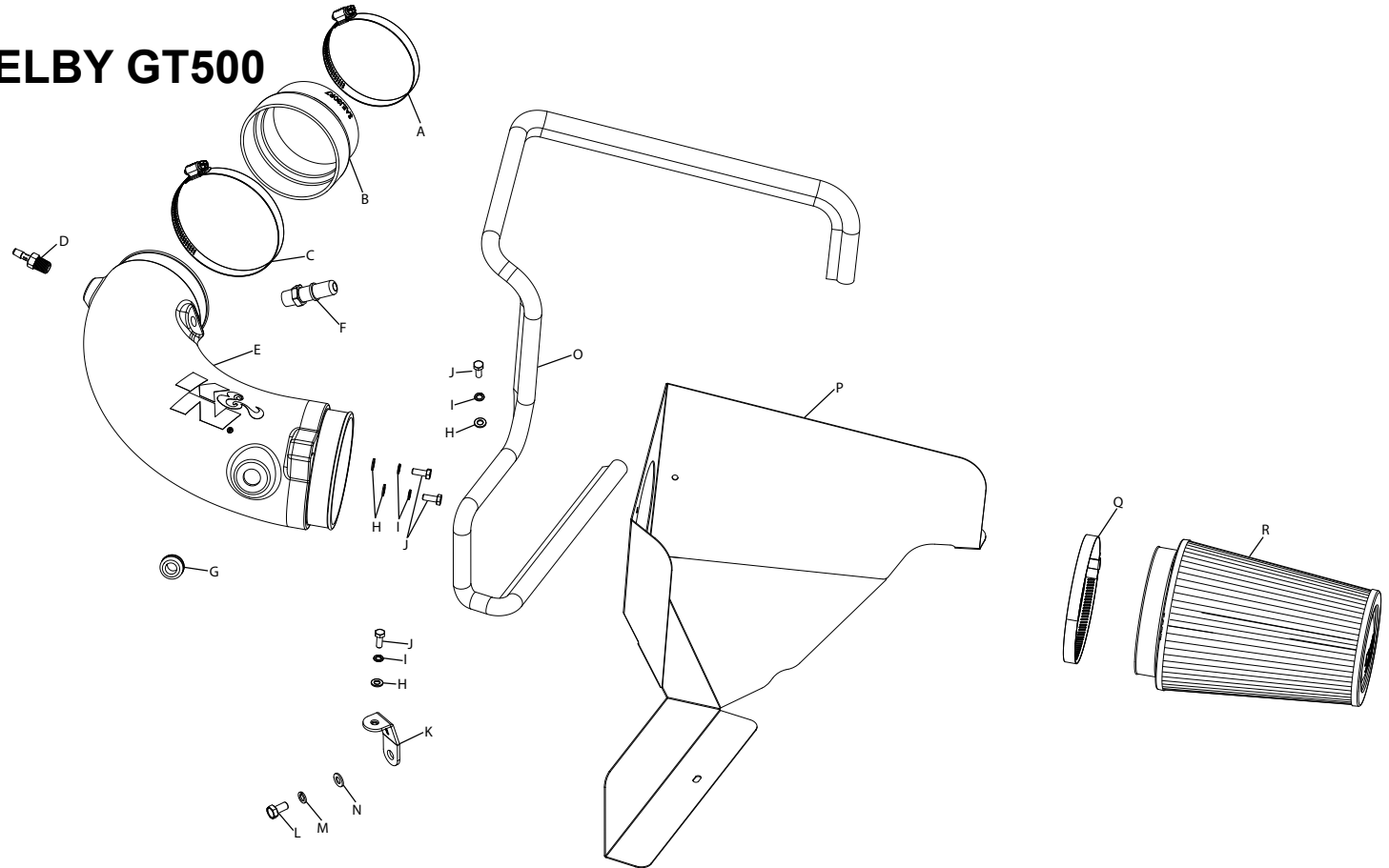

#### PARTS LIST:

Description	Qty.	Part #	Description	Qty.	Part #	Description	Qty.	Part #
A HOSE CLAMP; #64	1	08645KA	G GROMMET; 1"OD	1	08064	M WASHER; M8 SPLIT LOCK	1	1-3036
B REDUCER; 4.375"ID X 3.875"ID	1	KITRDCR16	H WASHER; 6MM FLAT	4	08269	N WASHER; 8MM FLAT	1	08272
C HOSE CLAMP; #72	1	08671KA	I WASHER; M6 SPLIT LOCK	4	1-3025	O EDGE TRIM 75"L	1	102460
D VENT; 1/4" HOSE	1	08046	J BOLT; M6-1 X 16MM	4	07812	P HEAT SHIELD, CRS	1	074523
E TUBE; (OO)	1	087482	K BRACKET; ANGLED	1	064369	Q HOSE CLAMP; #80	1	08694KA
F FITTING; 3/8" NPT	1	82637	L BOLT; 8MM-1.25 X 16MM	1	07844	R AIR FILTER	1	RP-2815

If you need any assistance please call 1-800-858-3333 to speak with a representative in our Customer Service Center before returning the product.

**NOTE: FAILURE TO FOLLOW INSTALLATION INSTRUCTIONS AND NOT USING THE PROVIDED HARDWARE MAY DAMAGE THE INTAKE TUBE, THROTTLE BODY AND ENGINE.**

#### TO START:

1. Turn off the ignition and disconnect the negative battery cable.  
**NOTE: Disconnecting the negative battery cable erases pre-programmed electronic memories. Write down all memory settings before disconnecting the negative battery cable. Some radios will require an anti-theft code to be entered after the battery is reconnected. The anti-theft code is typically supplied with your owner's manual. In the event your vehicles anti-theft code cannot be recovered, contact an authorized dealership to obtain your vehicles anti-theft code.**



2. Disconnect the IAT sensor electrical connection and unhook the wiring harness from the air filter housing.



3. Disconnect the two vent lines attached to the factory intake tube. Loosen the hose clamp that secures the intake tube to the throttle body.



4. Remove the four bolts that secure the air filter lid and then remove the lid from the vehicle.



5. Remove the intake tube and filter assembly from the vehicle.

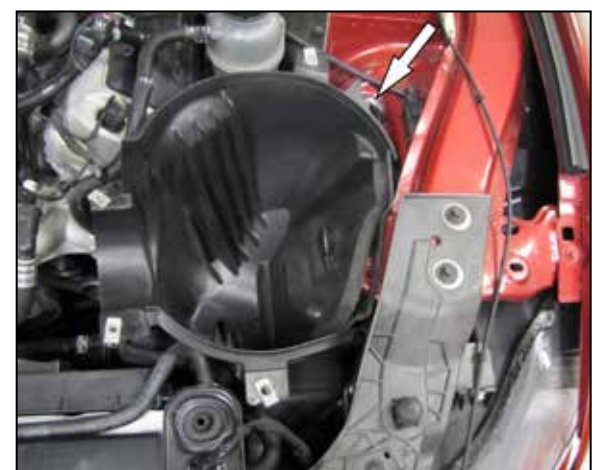

6. Remove the bolt that secures the factory air box to the inner fender and then remove it from the vehicle.



7. Secure the heat shield mounting bracket to the inner fender using the provided hardware.

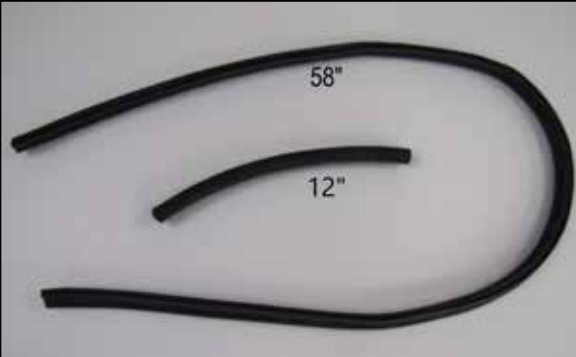

8. Cut the provided edge trim to 58" and 12" as shown.



9. Install the edge trim onto the heat shield as shown.



10. Install the heat shield into the vehicle and secure it to the inner fender and mounting bracket with the provided hardware.



11. Install the provided coupler onto the throttle body and secure with the provided hose clamp.



12. Remove the IAT sensor from the factory intake tube and install it into the K&N intake tube using the provided grommet.



13. Install the provided vent fittings into the K&N intake tube as shown.



14. Install the K&N intake tube into the heat shield and then into the coupler, align for best fit and then secure with the provided hardware and hose clamp.



15. Connect the two factory vent lines to the fittings installed into the K&N intake tube.



16. Reconnect the IAT sensor electrical connection.



17. Install the K&N air filter and secure with the provided hose clamp.



18. Reconnect the vehicle's negative battery cable. Double check to make sure everything is tight and properly positioned before starting the vehicle.

19. It will be necessary for all K&N® high flow intake systems to be checked periodically for realignment, clearance and tightening of all connections. Failure to follow the above instructions or proper maintenance may void warranty.

#### ROAD TESTING:

1. Start the engine with the transmission in neutral or park, and the parking brake engaged. Listen for air leaks or odd noises. For air leaks secure hoses and connections. For odd noises, find cause and repair before proceeding. This kit will function identically to the factory system except for being louder and much more responsive.

2. Test drive the vehicle. Listen for odd noises or rattles and fix as necessary.

3. If road test is fine, you can now enjoy the added power and performance from your kit.

4. K&N Engineering, Inc., requires cleaning the intake system's air filter element every 100,000 miles. When used in dusty or off-road environments, our filters will require cleaning more often. We recommend that you visually inspect your filter once every 25,000 miles to determine if the screen is still visible. When the screen is no longer visible some place on the filter element, it is time to clean it. To clean and re-oil, purchase our filter Recharger® service kit, part number 99-5050 or 99-5000 and follow the easy instructions.

**NOT LEGAL FOR SALE OR USE ON ANY POLLUTION CONTROLLED MOTOR VEHICLE IN CALIFORNIA OR STATES ADOPTING CALIFORNIA EMISSION PROCEDURES.**

See [knfilters.com](http://knfilters.com) for CARB status on each part for a specific vehicle