

# K&N TYPHOON INTAKE SYSTEMS

## INSTALLATION INSTRUCTIONS

### 69-8752

#### Toyota

2001-2004, Celica T-Sport  
1.8L L4 16v, 192 bhp

#### TOOLS NEEDED:

Phillips screwdriver  
Ratchet  
10mm socket  
2.5mm allen wrench  
3mm allen wrench  
4mm allen wrench  
Pliers

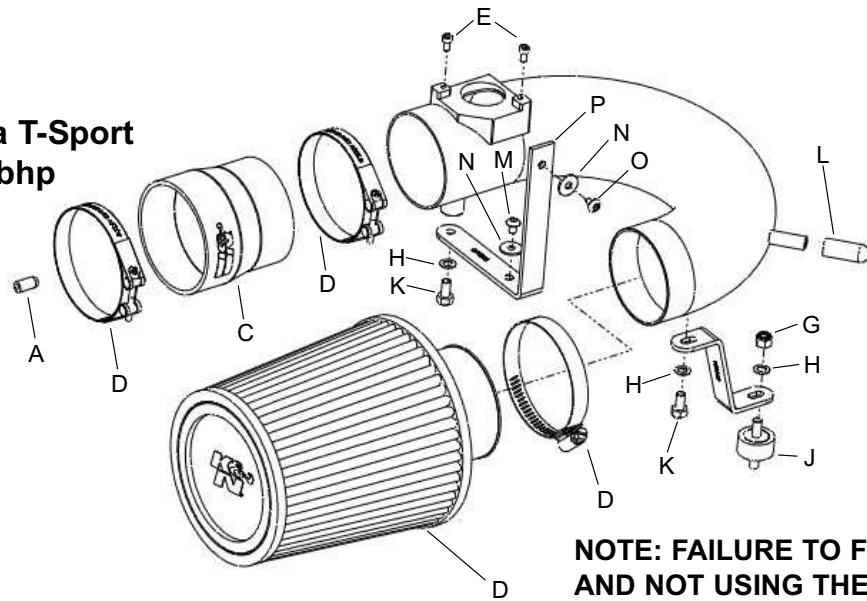

#### Parts List

Description	Qty.	P/N
A Rubber Cap, Small	1	08282
B Filter Element	1	KRU4870E
C Silicone Step Hose, Black	1	08096
D Hose Clamp, #44	3	08560
E 4mm Cap Head Screw, 8mm L.	2	07733
F Typhoon Intake Tube	1	27095
G 6mm Nylock Nut	1	07512
H 6mm Wave Washer	3	08277
I "Z" Bracket	1	070034
J Rubber Mounted Stud	1	07027
K 6mm Hex Bolt, 12mm L.	2	07727
L Rubber Cap, Large	1	08214
M 5mm Button Head Screw, 8mm L.	1	07740
N 5mm Flat Washer	2	08212
O 4mm Button Head Screw, 8mm L.	1	07741
P "L" Bracket	1	070035

#### TO START:

1. Turn the ignition OFF and disconnect the vehicle's negative battery cable.



2. Disconnect the mass air sensor electrical connection as shown.

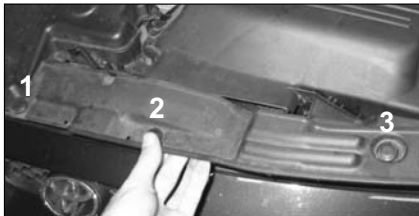

3. Release the 3 plastic clips and remove the valance/cover from the radiator core support.



4. Loosen and remove the bolt securing the air box base to the radiator core support as shown.



5. Unclip the PWM vacuum switching valve from the air box assembly as shown.



6. Loosen and remove the bolt securing the air box base to the inner fender as shown.



7. Loosen both hose clamps on the stock intake tube as shown.



**NOTE: FAILURE TO FOLLOW INSTALLATION INSTRUCTIONS AND NOT USING THE PROVIDED HARDWARE MAY DAMAGE THE INTAKE TUBE, THROTTLE BODY AND ENGINE.**



8. Remove the stock intake tube from the air cleaner assembly as shown.



9. Remove the vent hose from the air box assembly as shown.



10. Release the 3 clips and remove the air box lid from the vehicle as shown.



11. Remove the computer fresh air supply tube as shown.



12. Disconnect the vacuum line from the intake manifold as shown.



13. Pull upwards on air box base, so the bottom of the assembly is visible, then loosen and remove the bolt that secures the vacuum switching valve to the underside of the air box base as shown.

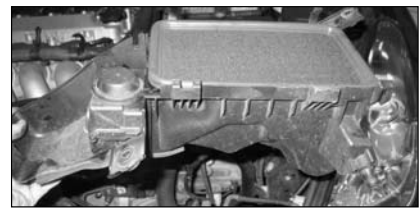

14. Remove the air box base from the car as shown.



15. Remove the stock intake tube from the throttle body as shown.

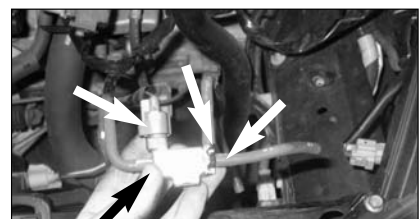

16. **2001-2004 models:** Remove the three stock rubber hoses and electrical connector from the vacuum switching valve as shown.

16a. **2005-later models:** Remove the stock rubber hose between the vacuum switching valve and air box.

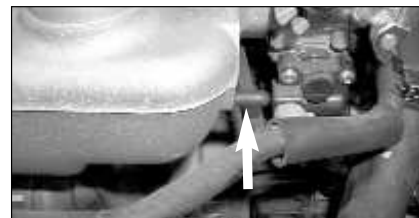

17. **2001-2004 models:** Install the small rubber cap plug onto the vacuum port on the manifold as shown.

18. **2005-later models:** Install the small rubber cap plug onto the air box port of the vacuum switching valve.



19. Mount the vacuum switching valve from step 16 to the provided "L" bracket with the hardware provided. On 2005-later models; hoses are still connected to the vacuum switching valve, so it has to be mounted in the engine bay.



20. Install the large rubber cap plug onto the vent on the K&N Typhoon intake tube as shown.



21. Loosen and remove the screws that secure the mass air sensor, then remove the mass air sensor from the air cleaner assembly as shown.



22. Install the mass air sensor into the K&N Typhoon tube and secure with the provided cap screws as shown. **NOTE:** Before installing the Mass air sensor, inspect the inside of the tube for any debris, then clean the inside out with water and a towel. Inspect the tube one more time before proceeding to the next step.

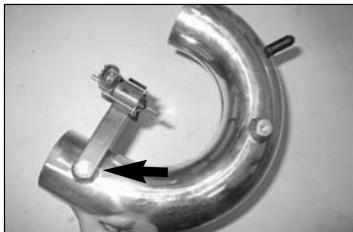

23. Install the "L" bracket onto the K&N intake tube using the provided hardware as shown.



24. Install the silicone step hose onto the throttle body using the #44 hose clamp supplied.



25. Install the provided rubber mounted stud into the original air cleaner mounting threaded hole as shown.



26. Install the "Z" bracket onto the rubber mounted stud using the provided hardware as shown. Do not fully tighten at this stage.



27. Install the K&N Typhoon intake tube into the silicone step hose using the #44 hose clamp as shown but don't completely tighten the hose clamp at this stage.



28. Secure the "Z" bracket to the threaded boss on the K&N Typhoon tube with the provided hardware. Do not fully tighten at this stage.



29. Remove the stock bracket from the PWM vacuum switching valve as shown.



30. Mount the PWM vacuum switching valve onto the upper part of the "L" bracket using the provided hardware as shown.



31. Reconnect the vacuum switching valve electrical connection as shown.

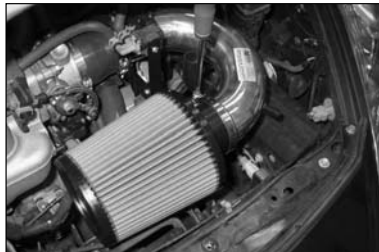

32. Install the K&N Filtercharger onto the K&N Typhoon tube as shown. Position the tube for best fit and clearance, then tighten all bolts and hose clamps.



33. Reconnect the MAS electrical connector.



34. Reconnect the computer fresh air tube to the computer housing as shown.



35. Reinstall the valance/cover onto the radiator core support using the 3 original retainer clips.



36. Reconnect the negative battery cable, then double check to make sure everything is tight and properly positioned before starting the vehicle.

37. It will be necessary for all Typhoons to be checked periodically for realignment, clearance and tightening of all connections. Failure to follow the above instructions or proper maintenance may void warranty.

#### ROAD TESTING:

1. Start the engine with the transmission in neutral or park, and the parking brake engaged. Listen for air leaks or odd noises. For air leaks secure hoses and connections. For odd noises, find cause and repair before proceeding. This kit will function identically to the factory system except for being louder and much more responsive.
2. Test drive the vehicle. Listen for odd noises or rattles and fix as necessary.
3. If road test is fine, you can now enjoy the added power and performance from your kit.
4. K&N suggests checking the Filtercharger element periodically for excessive dirt build-up. When the element becomes covered in dirt (or once a year), service it according to the instructions on the Recharger service kit, part number 99-5003EU

