



QUALITY... PLAIN & SIMPLE®

Rod Type Throttle Linkage Spring Return Kit Installation Instructions, For 4150 & 4500 Series Carburetors

General Installation Notes:

Please read these instructions completely before beginning the installation. If you have any questions please call.

Before beginning the installation, disconnect the negative battery cable and use wheel chocks to block the vehicle's wheels.

Lokar recommends using anti-seize lubricant on all aluminum threads.

Refer to Fig. 1 and Fig. 2 for the component names.

Step 1: Remove the 1/4"-20 thin nylock nut and the post washer from the spring stand assembly. Install the spring stand with the springs and spring tab onto the top side of the throttle linkage bracket, into the slot at the front left corner. Install the post washer (beveled edge out) and 1/4"-20 thin nylock nut on the bottom. **Fig. 3 and Fig. 4**

If you are going to be using a scoop tray, install the scoop tray stands onto the throttle linkage bracket using the 1/4"-20 x 3/4" socket head bolts and internal lock washers. The end of the scoop tray stand that has the shorter hex goes towards the bottom. **4150-Series Applications Only** also use a post washer on the 1/4"-20 x 3/4" socket head bolt at the right rear corner, where the scoop tray stand is bolted into a slot instead of a round hole.

Install the 1/4"-20 x 1-1/2" set screws into the top end of each of the scoop tray stands. **Fig. 5 and Fig. 6**

Step 2: Place a new carburetor gasket (not included) onto the intake manifold. Then install the throttle linkage bracket onto the intake manifold with the spring assembly on the left towards the front. Place a new carburetor gasket (not included) on top of the throttle linkage bracket, and install the carburetor.

Step 3: Connect the springs to the carburetor:

- **4150 Series Carburetors:** Place the tab bushing onto the 1/4"-28 x 5/8" button head bolt with the larger diameter side towards the head of the bolt. Insert the button head bolt and the tab bushing into the large round hole in the spring tab. Install this assembly into the return spring hole on the carburetor throttle arm, and secure with the 1/4" flat washer and 1/4"-28 nylock nut. Make sure the recess in the tab bushing is seated over the lip on the carburetor throttle arm, and that the spring tab will rotate freely on the tab bushing. **Fig. 7**

Rod Type Throttle Linkage Spring Return Kit Installation Instructions, For 4150 & 4500 Series Carburetors

Building American Quality... With A Lifetime Warranty!®

TOLL FREE 1-877-469-7440 • tech@lokar.com • www.lokar.com

4150 Series

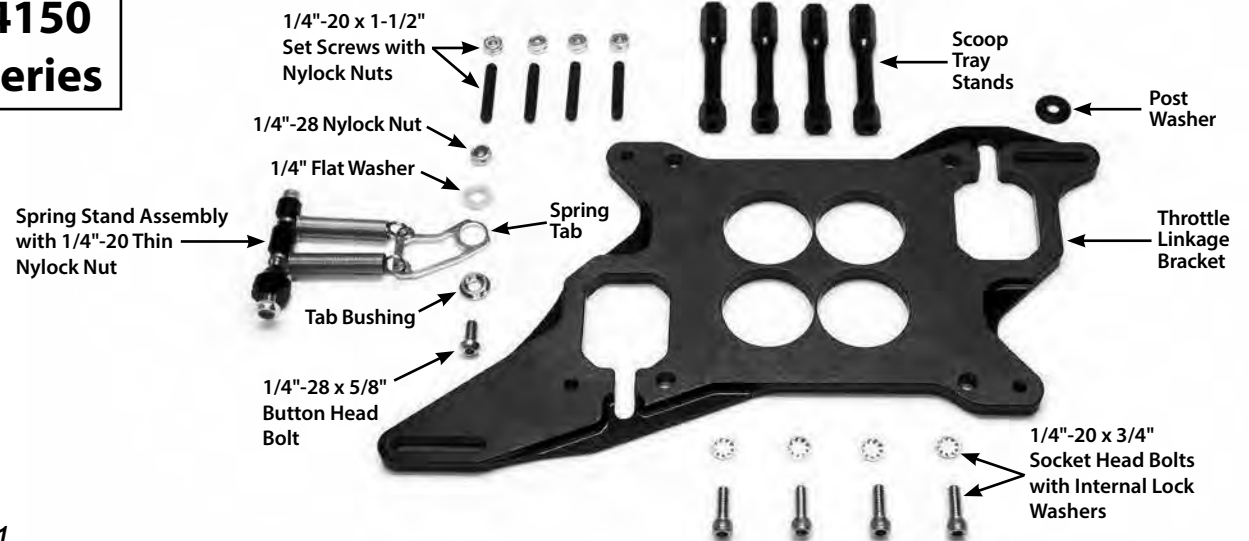

Fig. 1

4500 Series

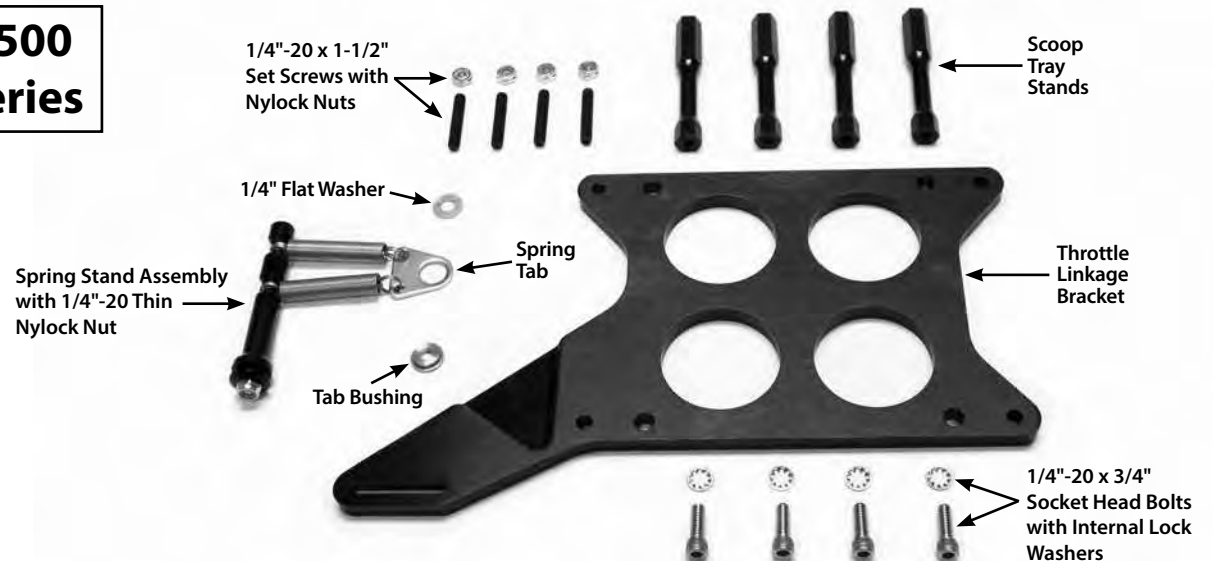

Fig. 2

Rod Type Throttle Linkage Spring Return Kit Installation Instructions, For 4150 & 4500 Series Carburetors

4150 Series

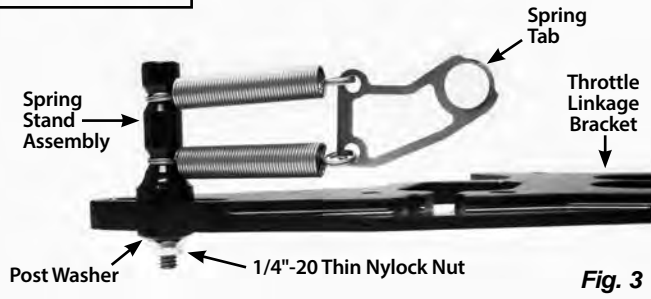

Fig. 3

4500 Series

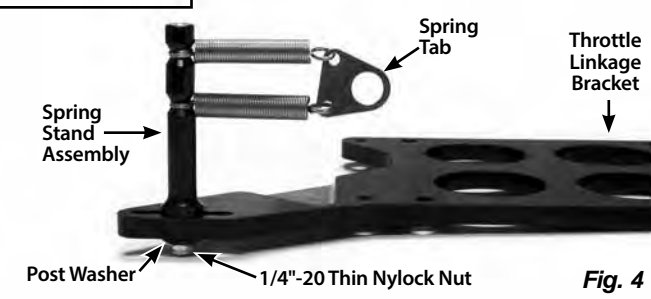

Fig. 4

Step 3 (continued):

- **4500 Series Carburetors:** Place the tab bushing onto your carb linkage stud (not included), with the larger diameter side towards the linkage rod. Insert the carb linkage stud and tab bushing into the spring tab. Install this assembly onto the carburetor throttle arm, and secure with the provided 1/4" flat washer and your original nylock nut (not included). Make sure that the spring tab will rotate freely on the tab bushing. **Fig. 8**

Step 4: Connect the throttle linkage to the carburetor.

If you are using a scoop tray, the remaining 1/4"-20 nylock nuts can be used to fasten the scoop tray to the top of the scoop tray stands.

NOTE: Before starting the engine, check the carburetor and throttle linkage to make sure there is no binding and that the throttle returns all the way to the closed position.

4150 Series

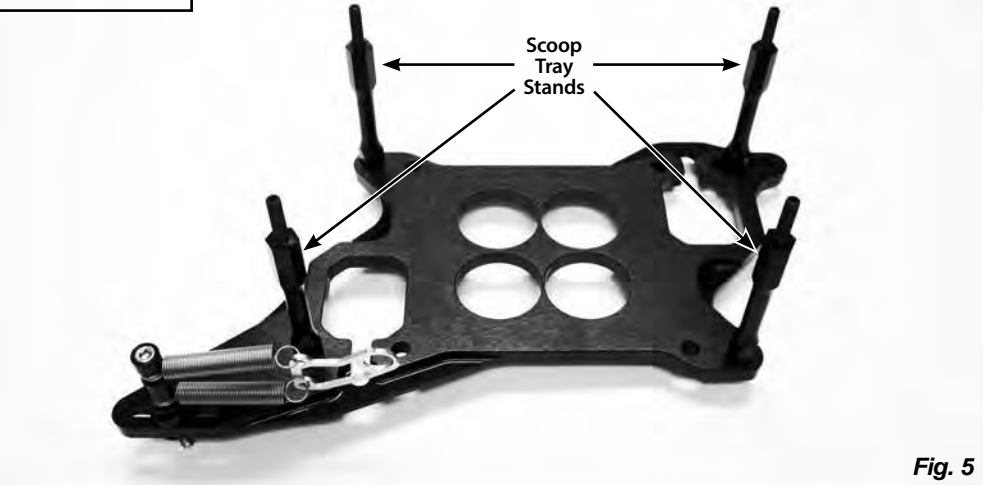

Fig. 5

4500 Series

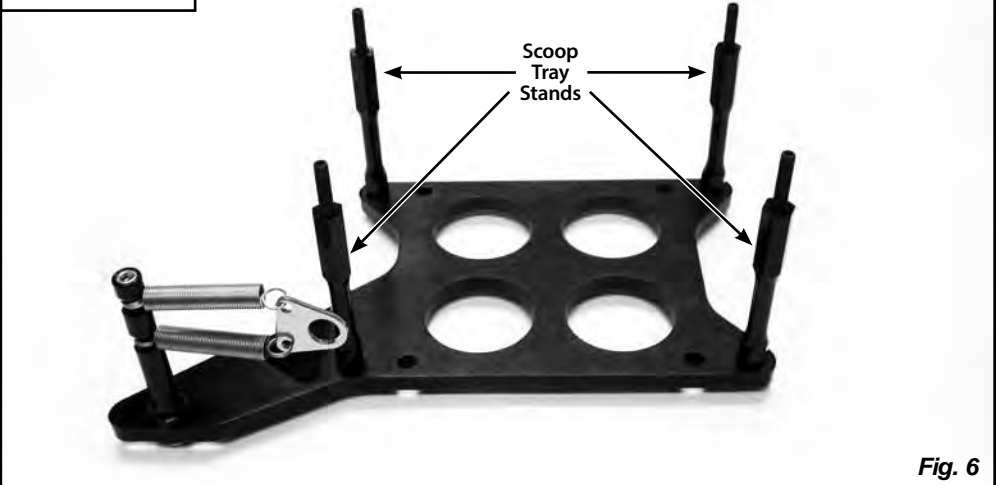

Fig. 6

4150 Series



Fig. 7

4500 Series

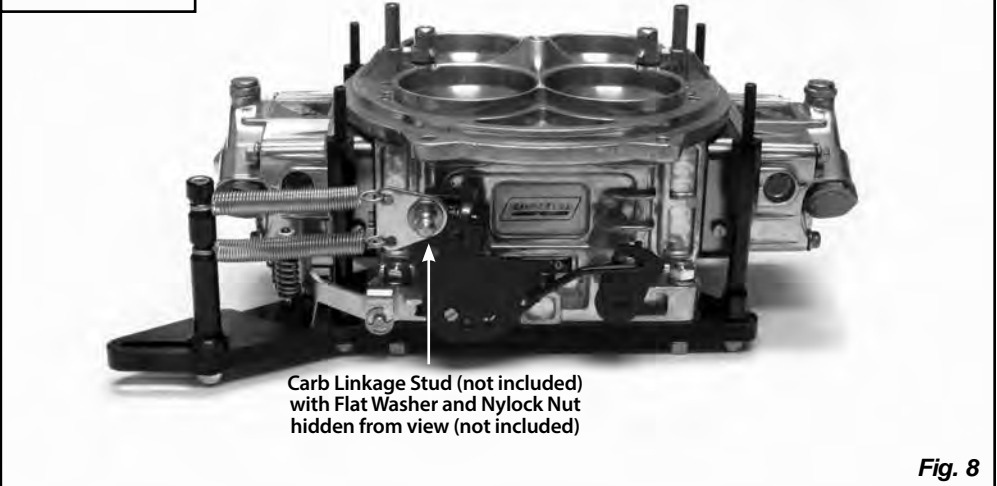

Fig. 8