



QUALITY... PLAIN & SIMPLE®

Under-the-Dash Foot Operated Emergency Brake Instructions
Part # EFB-9000 through EFB-9009, XEFB-9001 and XEFB-9003

STOP! Read all installation instructions before beginning installation. Please call Lokar with any questions or uncertainties that may arise during the installation.

APPLICATION NOTE: Footbrake requires the use of Lokar Connector Cables for proper installation. See below for Part Numbers.

GENERAL INSTALLATION NOTES: Begin the installation by planning out exactly where under the dash to install the E-brake assembly and how it is to be mounted. The E-brake assembly has been designed so that it can be mounted to either the firewall or a side structure. The mounting brackets are fully adjustable so that the assembly can be mounted in an easy to operate position in any make or model car, and the cut to fit release rod is extra long so that it can be bent to pull straight if the assembly is mounted higher than the bottom of the dash. Though the installation is fairly simple, beginning without forethought can result in the drilling of unwanted holes, causing unnecessary repairs of the firewall and/or side structures.

WARNING: Disconnect the battery before beginning installation. Make sure the vehicle is in Park and at least one tire is scotched to prevent the vehicle from moving.

TOOLS YOU WILL NEED:

Drill, 3/8 Drill Bit, Standard Size Allen Wrenches, Standard Wrenches, Scribe, Center Punch, Hammer

ADDITIONAL LOKAR PARTS NEEDED:

EC-8001U (Black Connector Cable) or EC-8001HT (Stainless Connector Cable) Lokar Parking Brake Cables that are appropriate for your rear brakes.

Under-the-Dash Foot Operated Emergency Brake Instructions

Part # EFB-9000 through EFB-9009, XEFB-9001 and XEFB-9003

Building American Quality... With A Lifetime Warranty!

10924 Murdock Dr. • Knoxville, TN 37932

TOLL FREE 1-877-469-7440 • (865) 966-2269 • FAX (865) 671-1999 • tech@lokar.com • www.lokar.com

Under-the-Dash Emergency Brake Installation

Step 1: The Under-the-Dash Footbrake comes assembled with 5/16-24 x 1 1/2" bolts and 5/16-24 non-locking nuts. The non-locking nuts will make the installation easier but are to be used for convenience only and must be discarded and replaced with the 5/16" nylock nuts during the final assembly.

Step 2: Hold complete E-brake assembly in position at firewall and outline firewall mount slider bracket with a scribe or pencil. Once position is marked, remove the firewall mount slider bracket from the main frame, place bracket over outline and mark the three 5/16 mounting holes. If you are mounting the assembly to side structure, use the side adjustment slots for mounting.

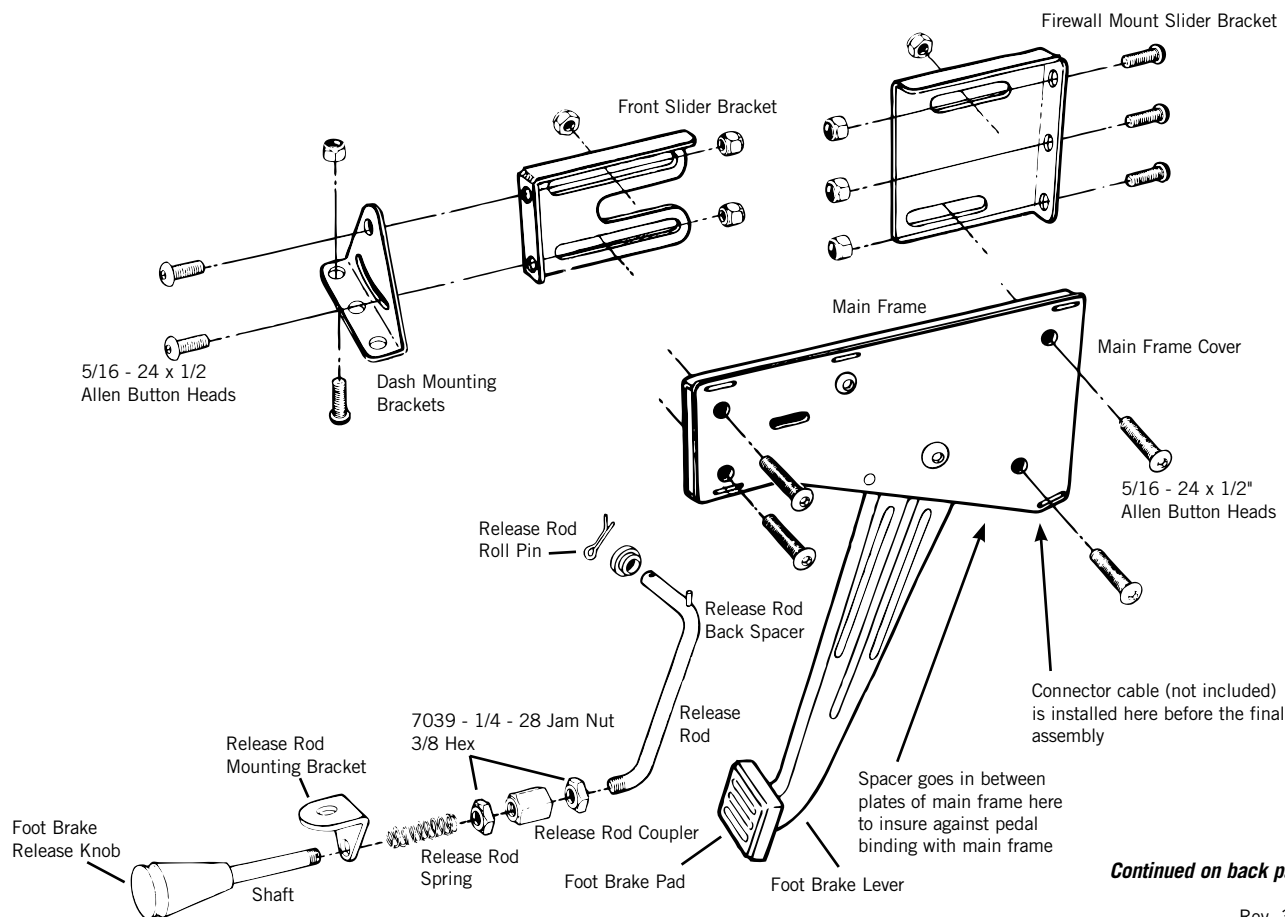

Continued on back page...



QUALITY... PLAIN & SIMPLE®

Under-the-Dash Foot Operated Emergency Brake Instructions
Part # EFB-9000 through EFB-9009, XEFB-9001 and XEFB-9003

Step 3: After drilling and mounting firewall, mount slider bracket to firewall or side structure, bolt E-brake assembly to firewall mount slider bracket and slide into desired location. Now install the front slider bracket to the main frame in order to locate the dash mounting bracket. The dash mounting bracket has a curved slot in it to allow for many different dash angles. The dash mounting bracket comes with three mounting holes for mounting to the back of the dash. However, one mounting bolt to the dash is sufficient. When looking at the footbrake assembly from the driver's position, the right hand dash mounting bracket hole can also be used to mount the release rod mounting bracket. Two 1/4-28 x 5/8" allen bolts and nylocks are provided to mount the dash mounting bracket and the release rod mounting bracket.

Step 4: Once dash mounting bracket and firewall mount slider bracket have been mounted and main frame is in position, the L-shaped release rod can be cut-to-fit. Slip the footbrake release knob through the release rod mounting bracket, install release rod spring, and adjust nut up just enough to take the slack out and put some tension on the release rod spring. Release rod spring must not be loose. Line up release rod level with footbrake release knob and mark and cut with a hack saw.

Under-the-Dash Foot Operated Emergency Brake Instructions

Part # EFB-9000 through EFB-9009, XEFB-9001 and XEFB-9003

Building American Quality... With A Lifetime Warranty!

10924 Murdock Dr. • Knoxville, TN 37932

TOLL FREE 1-877-469-7440 • (865) 966-2269 • FAX (865) 671-1999 • tech@lokar.com • www.lokar.com

Step 5: Before final installation of release rod, remove main frame assembly from mounting brackets and remove main frame cover. Now install Lokar Connector Cable, (Part No. EC-8001U Black housing or EC-8001HT Stainless housing; Not included with footbrake kit.)

NOTE: Housing of brake cable must be cut to length before inner wire installed. Once cable is installed, replace main frame cover. Assemble using the 5/16-24 nylock nuts and dispose of the non-locking nuts. Do not over tighten assembly. Over tightening can distort assembly and bind pedal. Run connector cable under vehicle and install Lokar emergency brake cables to rear brakes. To look up the correct part number for your application, check www.lokar.com. To place an order, call toll free 1-877-469-7440 or call your nearest dealer.

