

PowerBright™



XTW2000 XTW3000

PURE SINE WAVE
POWER INVERTER

USER'S MANUAL

PLEASE READ THIS MANUAL CAREFULLY BEFORE OPERATION. S.V.P., LIRE CE MANUEL AVEC SOIN AVANT UTILISATION
Copyright 2009 Bright Manufacturing, LLC No part of this document may be copied without written permission.

Read these instructions before connecting and using your PowerBright™ Pure Sine Power Inverter. Failure in observing this warning may result in injury to persons and damage to equipment.

General safety and installation information.

Warning! The following fundamental safety measures must be observed when using electrical equipment to avoid danger of:

- **Electric shock**
- **Fire**
- **Injury**

About the unit itself

- The inverter must only be used for the purpose specified by the manufacturer.
- Do not operate the inverter if the housing of Cables are damaged.
- The inverter must be positioned and secured safely in order to avoid knocking over or dropping.
- If casing needs to be opened, make sure Input cables have been properly disconnected.
- The inverter must be kept in a safe place out of the reach of children.
- The inverter may not be operated in a damp or wet environment.
- The inverter may not be used in rooms containing flammable materials.
- Make sure the inverter is well ventilated.
- Service and repair may only be carried out by skilled persons who are familiar with the risks involved and the relevant regulations.

Caution for installation on boats

- Incorrect installation of electrical units on a boat may lead to corrosion of the inverter. Therefore, please let an electrician carry out the installation of the inverter.

Intended use

The inverter is suitable for e.g. high-quality appliances from the audio, video or PC.

The output voltage corresponds to the standard one of your socket (pure sinus-voltage).

Attention! Please note that appliances like drills, TV's or refrigerators require a high starting-current which is far over the nominal current.

FRONT PANEL

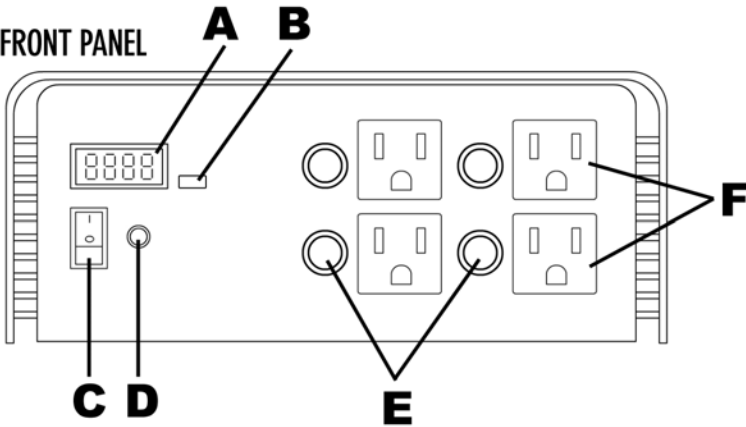

A. Digital Display for DC Volts or AC Watts.

B. Display Selector Switch – DC Volts or AC Watts.

C. ON/OFF Switch. Turns the inverter circuits ON and OFF

D. Overload LED Indicator. If continuous power draw of appliance(s) exceeds maximum continuous wattage, this light will turn ORANGE/RED and the inverter will automatically shut down. When this occurs, turn off the inverter and determine the cause of the overload before turning the inverter and the appliance back on.

E. Breakers

F. Four standard North American AC outlets, each rated at 15 Amps (1650 Watts).

REAR PANEL

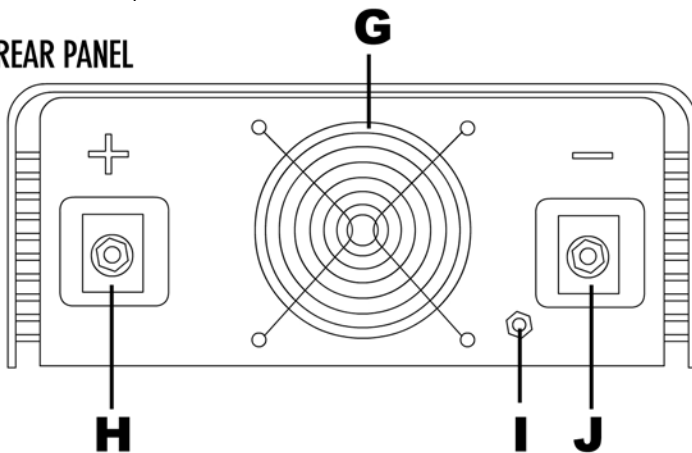

G. High-Speed Cooling Fans. When the temperature inside the inverter exceeds a preset limit, the Cooling Fan automatically turns on to cool the inverter. When the temperature reduces, the fan turns off.

H. Positive Power Input Terminal.

I. Ground Terminal

J. Negative Power Input Terminal.

Required tools and installations equipment

Depending on type of installation, the following tools are required:

- set of screw drivers
- drill and set of bits
- wrench
- crimping shears for the 12/24V wire connection

For connection of inverter to the battery, the following cable connecting hardware is needed:

- 2 different flexible cable connections.
- Various terminals, multi-core cable ends

Caution:

Before drilling any mounting holes, make sure that there are no wires, fuel lines or tanks directly below the surface being drilled.

Installation

The inverter has to be installed in a dry and clean place not being exposed to humidity.

Make sure there is proper ventilation.

Keep at least a free space of 10 cm surrounding the inverter.

If installed into housing, make sure there's good ventilation.

The air intake on the bottom of the inverter and the air outlet on the back side may not be blocked.

In case of ambient temperatures of more than 35C (e.g. engine or heating room, direct sunlight), the inverter will switch off automatically, because of self heating effects during operation.

The installation surface must be balanced and sufficiently strong.

Installation of the inverter

-Adjust the inverter to the chosen installation place and mark the fixing points.

-Fix the inverter by using the self chosen fixing method.

Electrical connection

General instructions for electrical connection.

In case of the inverter is installed into vehicles or boats it has to be connected to the chassis (ground).

If cables have to be inserted to metal walls or other sharp-edged means, use a cable duct or cable bushes.

Do not pull the cables.

Do not lay cables loose or in sharp bends on electrical conducting materials (metal).

Do not lay 110V mains cable and 12/24 VDC cable together into the same cable duct.

The specified minimum cable cross section must be complied with.

Secure cables properly.

Lay cables in such a way that no tripping is possible.
Lay cables in such a way that no exposure to, or risk of, damage is possible.

Cables: Make sure to use the correct cables. A chart is provided below, for your reference:

Max. Watt Output	Wire Gauge
2000W	#2 or 2 x #6
3000W	#0 or 2 x #4

Connection to the battery

-Lay the flexible connecting cable (positive) and (negative) from the battery to the connecting terminals of the inverter (take cable cross section from the table).

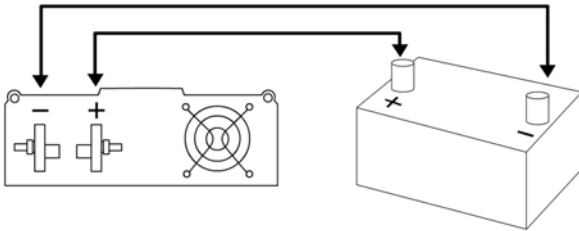

-Connect the positive first, then the negative cable.
! Make sure the terminals are not reversed!
Reverse polarity connection will blow the internal fuses. This will void the warranty.

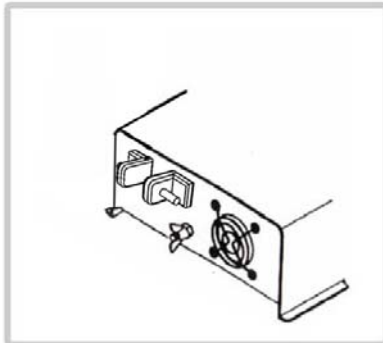
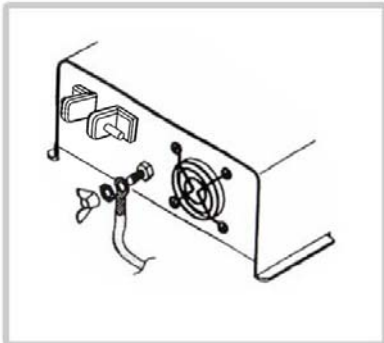

-Lay the flexible chassis ground cable from the chassis of the vehicle to the chassis ground on the rack of the inverter.
-Connect the chassis ground.

! Reverse polarity connection of the battery wires can damage the inverter. Do not use the inverter with electrical systems using positive ground.

Operation: 2000W / 3000W pure sine wave inverter

Power on:

On the LED control “Power” lighting - Green LED.

Over load:

One the LED control “Over-Load” lighting - Red LED.

Over temperature:

On the LED control “Over-Temp” lighting - Red LED.

Problem	Possible Cause
No output voltage, LED does not light	1. On/Off switch is not in the power ON position. 2. Bad contact of the connections between battery and inverter. 3. Internal fuses blown. In this case, send the unit back to Power Bright for repair.
No output voltage, OVER-TEMP LED Lights Red	The inverter has been overheated. Switch off the inverter and the device. Wait approx. 2 minutes and switch on the inverter only. Reduce the load and make sure that there is better ventilation for the inverter. Then switch on the inverter and the device again.
Overload LED	Current consumption of the device is too high. Also there could be a short of the device. Switch off the inverter and disconnect the device. Switch on the inverter again. If the OVERLOAD LED is off, there is a short circuit in the device or the total load was higher than the specified wattage of the inverter. Check the connecting cable of the consumer for mechanical damages.
Audible signal in case of under voltage	Battery voltage too low. In case of the battery load voltage falls below 11V (12 Volt Model) resp. 22V (24 Volt Model). The battery has to be re-charged.

Specifications:

Model	XTW2000-12	XTW2000-24	XTW3000-12	XTW3000-24
Continuous Power	2000W	2000W	3000W	3000W
Surge	4000W	4000W	6000W	6000W
Output Voltage	110V+/-3%	110V+/-3%	110V+/-3%	110V+/-3%
Output Freq.	60Hz	60Hz	60Hz	60Hz
Output Waveform	Pure Sine	Pure Sine	Pure Sine	Pure Sine
Total Harmonic Distortion	< 3%	< 3%	< 3%	< 3%
Input Voltage Range	10V-15V	20V-30V	10V-15V	20V-30V
Efficiency	> 85%	> 85%	> 85%	> 85%
No Load Current Draw	0.85 amp	0.85 amp	0.85 amp	0.85 amp
Low Battery Alarm	10.7V	21.4V	10.7V	21.4V
Low Battery Shut-Down	10V	20V	10V	20V
Dimension (L x W x H)	16 x 8.9 x 6.1 in.	16 x 8.9 x 6.1 in.	19.9 x 8.9 x 6.1 in.	19.9 x 8.9 x 6.1 in.
Weight	20 lbs	20 lbs	25 lbs	25 lbs

PowerBright™

www.PowerBright.com

TOLL FREE: 1-866-295-6775



XTW2000

XTW3000

PURE SINE WAVE
POWER INVERTER

Printed in China