



## Universal Electric Water Pump Harness & Relay Kit Part # 40210G Installation Instructions

**WARNING! Check for any coolant leaks before starting vehicle.**

Route the wires away from heat and sharp metal edges that may cause melting or damage to the wires. Use crimping tools or solder and heat shrink tubing when making wiring connections. Do not use electrical tape to hold the wires together.

1. For best results, mount the relay as close as possible to the electric water pump.
2. Use the sheet metal screw to mount the relay connector to the vehicle. This sheet metal screw can also be used to provide ground by attaching the GREY 18-gauge wire – as long as the screw is mounted to a good vehicle ground (i.e. metal chassis or body of the vehicle). The Grey wire can also be mounted in another location to provide a good known ground.
3. Route and connect the BLUE 12-gauge wire to the POSITIVE (+) wire on the electric water pump.
4. Mount the circuit breaker near the power source you will be using to power the electric water pump. Typical power sources are the POSITIVE (+) side of the battery, or the large POSITIVE (+) terminal on the starter solenoid.
5. Route and cut the RED 10-gauge wire so that it terminates near the circuit breaker. Use the ring crimp terminals to connect the circuit breaker in-line with the power circuit. Note the circuit breaker will make a “pop” sound if the system is overloaded, and will automatically reset once it has cooled down.
6. Route the YELLOW 18-gauge wire to the “On/Off” switch for the electric water pump (this switch must be powered by a fused 12 volt source).

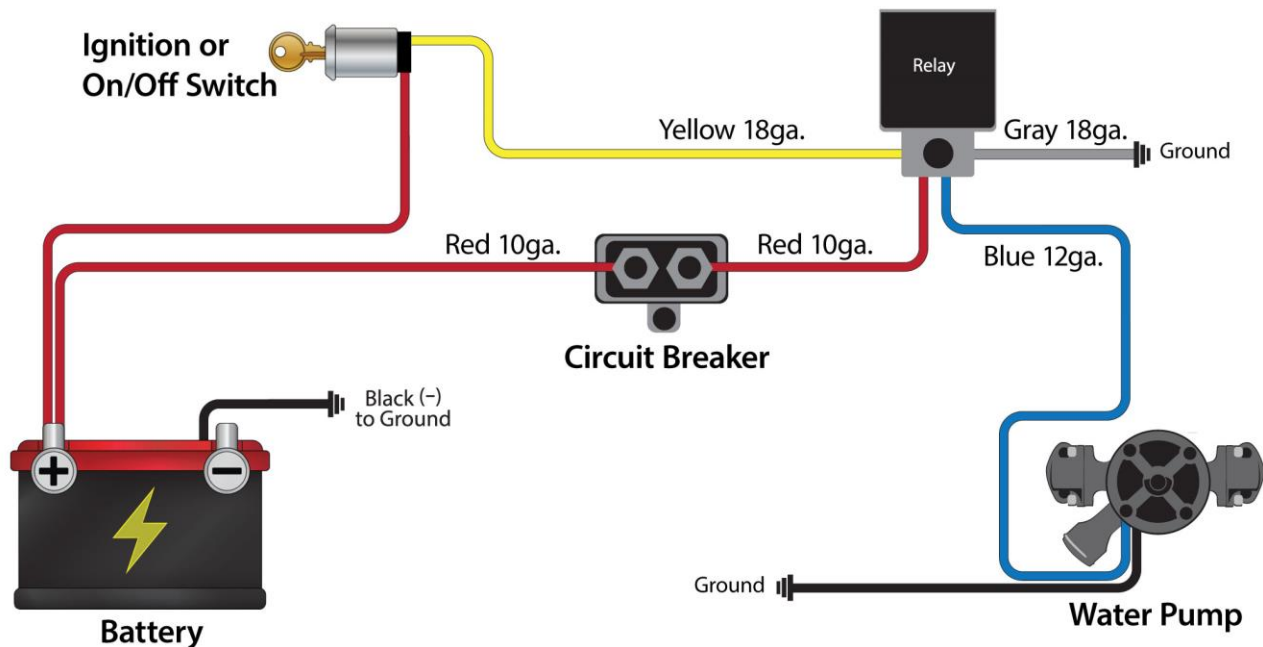

199R11500  
Date: 1-22-18