

QuickJack Crossbeam Adapter

Quick Start Guide

P/N 5900240 — Rev. A3 — March 2020

The Crossbeam Adapter lets you hit the Lifting Points on Vehicles with uneven Frames/Lifting Points.

The components of the QuickJack Crossbeam Adapter are:

- **One Crossbeam.** Installs on one end of a QuickJack between the QuickJack Frames.
- **Two Crossbeam Lift Pads.** Slide across the *top* of the Crossbeam, which lets you position them under the Vehicle's Lifting Points. Prevented from slipping off the Crossbeam by Bolt/Square/Nut **at each end.**
- **Two Crossbeam Bases.** Slide across the *bottom* of the Crossbeam. Sit in QuickJack Receiver Trays.
- **Two Round Lift Pads and Base Adapters.** Sit in the Receiver Trays at the opposite end of the QuickJack.

When using the Crossbeam Adapter, **do not** use the normal QuickJack Lift Blocks. The Crossbeam Adapter components are designed to be used **only with each other, not** the standard QuickJack Lift Blocks.

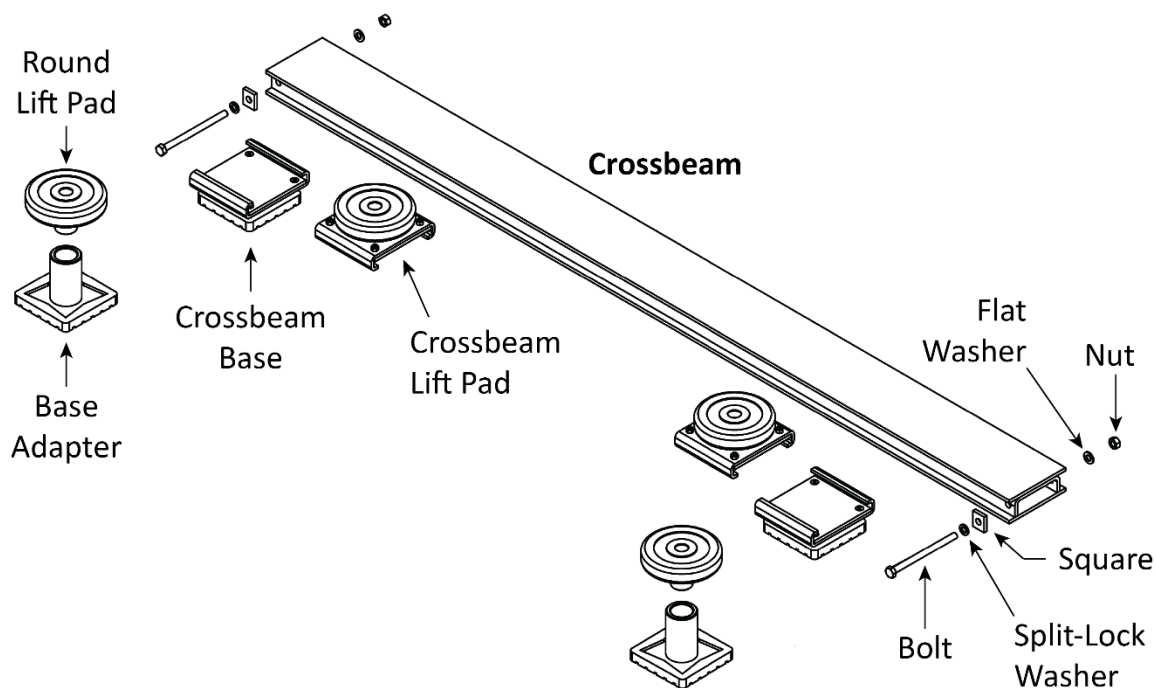

Usage Requirements:

- The Crossbeam Adapter can be used on QuickJack models BL-5000SLX, BL-5000EXT, BL-7000SLX, BL-7000EXT, and BL-6000XLT (order the BL-7000 option). It **cannot** be used on the BL-3500SLX.
- There is one correct orientation of the Vehicle over the QuickJack when using the Crossbeam Adapter: the part of the Frame with the **narrower** distance between Lifting Points goes over the Crossbeam.
- The Crossbeam Adapter increases the Lowered Height of the QuickJack by 3.4 in / 86 mm.
- The Crossbeam Adapter **cannot** be used with the SLX Frame Extension Kit.
- Only use one Crossbeam Adapter per pair of QuickJack Frames.
- The distance between the centers of the Vehicle's Frames at their widest must be 60 in / 1,526 mm **or less**.
- The distance by which the Vehicle's Frames are uneven must be 17 in / 431 mm **or less** for the BL-7000 series, 20 in / 508 mm **or less** for the BL-6000XLT, or 24 in / 609 mm **or less** for the BL-5000 series.

QUICKJACK™

250 Dove Court
Santa Paula, CA, 93060 USA

The following drawing shows a QuickJack equipped with the QuickJack Crossbeam Adapter sitting under the partial Frame of a Vehicle with uneven Lifting Points.

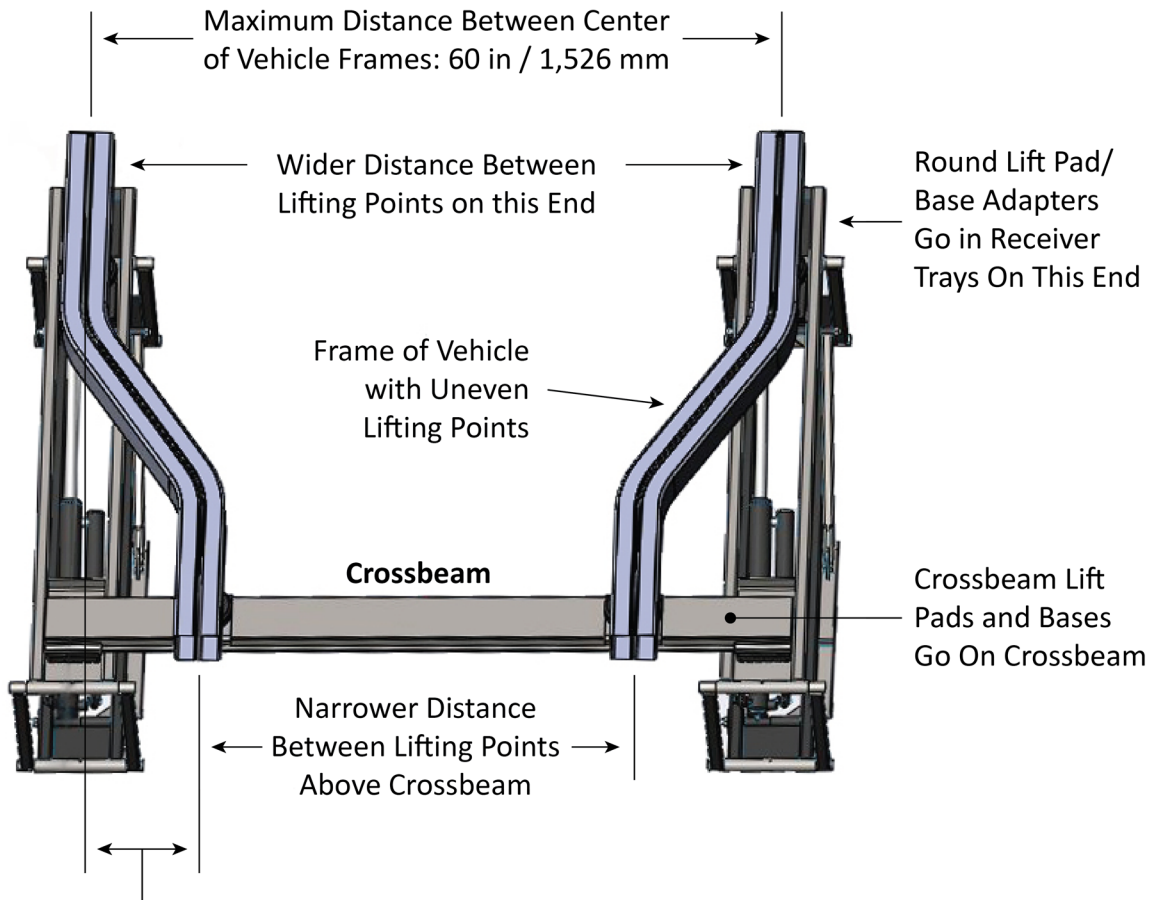

Maximum Allowed Distance:

BL-7000: 17 in / 431 mm, BL-6000: 20 in / 508 mm, BL-5000: 24 in / 609 mm

To use the QuickJack Crossbeam Adapter:

1. Reread the Usage Requirements on the previous page; your safety depends on adhering to them.
2. Set up the QuickJack normally based on the wider portion of the Vehicle's Frame.
3. Slide the Crossbeam Lift Pads onto the Crossbeam; move both towards the center of the Crossbeam.
4. Slide the Crossbeam Bases onto the Crossbeam, one near each end.
5. Put the Crossbeam and the Crossbeam Bases into place; the Crossbeam Bases go into the appropriate Receiver Trays on the QuickJack Frames.

The Crossbeam goes at the end of the Vehicle Frame with the narrower distance between Lifting Points.

6. Install one Bolt/Square/Nut combination on each end of the Crossbeam (to hold the Lift Pads on).
7. Put the Round Lift Pads and Base Adapters in the Receiver Trays on the other end of the QuickJack.
8. Move the Vehicle into position over the QuickJack Frames.

Remember to orient the Vehicle correctly over the QuickJack; narrower Frame end over the Crossbeam.

9. Make sure all of the Lift Pads are directly under the Vehicle's Lifting Points.

If they are not, adjust them so that they are.

10. Continue raising the Vehicle per the instructions in the QuickJack Manual.