



2501 Ludelle Street  
Fort Worth, Texas 76105  
817-244-6212 Phone • 817-244-4024 Fax  
888-350-6588 Sales • 800-423-9696 Tech  
E-mail: [painless@painlessperformance.com](mailto:painless@painlessperformance.com)  
Web: [www.painlessperformance.com](http://www.painlessperformance.com)

# 30107 & 30108

## 3-PACK/ 6-PACK RELAY BANK

### INSTALLATION INSTRUCTIONS

The wire in this kit has been printed and color coded to aid you during the installation process. All power wires in this kit, with the exception of the Red “Battery Power” wires, will be Red with a stripe and labeled “Activation Power”. All Ground wires in this kit will be Black with a stripe and labeled “Activation Ground”. The stripe color changes for each relay and corresponds to the solid color of the “Output” wire. The power output wires coming from the relays will need to be connected to the accessory or component you are powering through the relay. RED/GRN for example would be Red with a Green stripe and is the power for the relay with the Green “Output” wire. BLK/PNK for example would be Black with a Pink stripe and is the ground for the relay with the Pink “output” wire.

There are 2 different methods that can be used to activate a relay, power activation or ground activation. With “Power Activation”, the relay is grounded and the power into the relay is on a switch. This power can either be a switched “ignition hot” power source or a battery “constant hot” power source (See **Figure 1**). With “Ground Activation”, power into the relay is run directly from the power source to the relay. Again, this power can either be a switched “ignition hot” power source or a battery “constant hot” power source. The ground wire is connected to the switch (See **Figure 2**).

### Installation:

\*Route wires away from sharp edges, exhaust pipes, hood, trunk and door hinges. Inside edges provide protection from hazards and also provide places for tie wraps, clips, and other support.

1. Begin by deciding on a good location to mount the bank of relays.
2. Using 2 (3 bank relay kit) or 4 (6 bank relay kit) of the screws supplied with the parts kit, mount the relay bank in the pre determined location.
3. Route and connect the GRN “Output” wire from Relay #1 to the component to be powered (fuel pump, water pump, lights, etc.).
4. A decision must be made on how to activate the relay, Power Activated or Ground Activated.
5. Route and connect the “Activation Power”, RED/GRN, to an appropriate power source. The deciding factor of the power source is if the relay is to be activated with the ignition switch in the “on” position, or if the relay will ever be need to be activated with the ignition in the “off” position. (See **Figure 1 or 2**) according to the method of activation you choose.

6. Route and connect the “Activation Ground”, BLK/GRN, to ground. (See **Figure 1 or 2**) according to the method of activation you choose. If you choose to power activate all of the relays, all ground wires (Black with a stripe) can share the same common ground.
7. Follow steps 3, 4, 5, and 6 for the remaining relays.
8. Using the remaining screws, mount the circuit breaker(s) in a convenient location close to the battery.
9. Route the RED wire(s) labeled “To Battery” to the circuit breakers.
10. Connect the RED wire to one side of a circuit breaker. Make this connection by cutting the extra length of the RED wire and using a ring terminal, washer and nut supplied with the parts kit. (See **Figure 3**) Do the same with the other RED wire and the other circuit breaker. (6-Bank Relay kit only)
11. You now have 2 pieces of red wire you cut from the RED “To Battery” wire. Install a ring terminal onto the end of each of the wires. These ring terminals will now be connected to the empty posts on each circuit breaker using the other nuts and washers in the parts kit. (See **Figure 3**)
12. The remaining end needs to be connected to the “+” terminal of the battery using ring terminals from the parts kit.

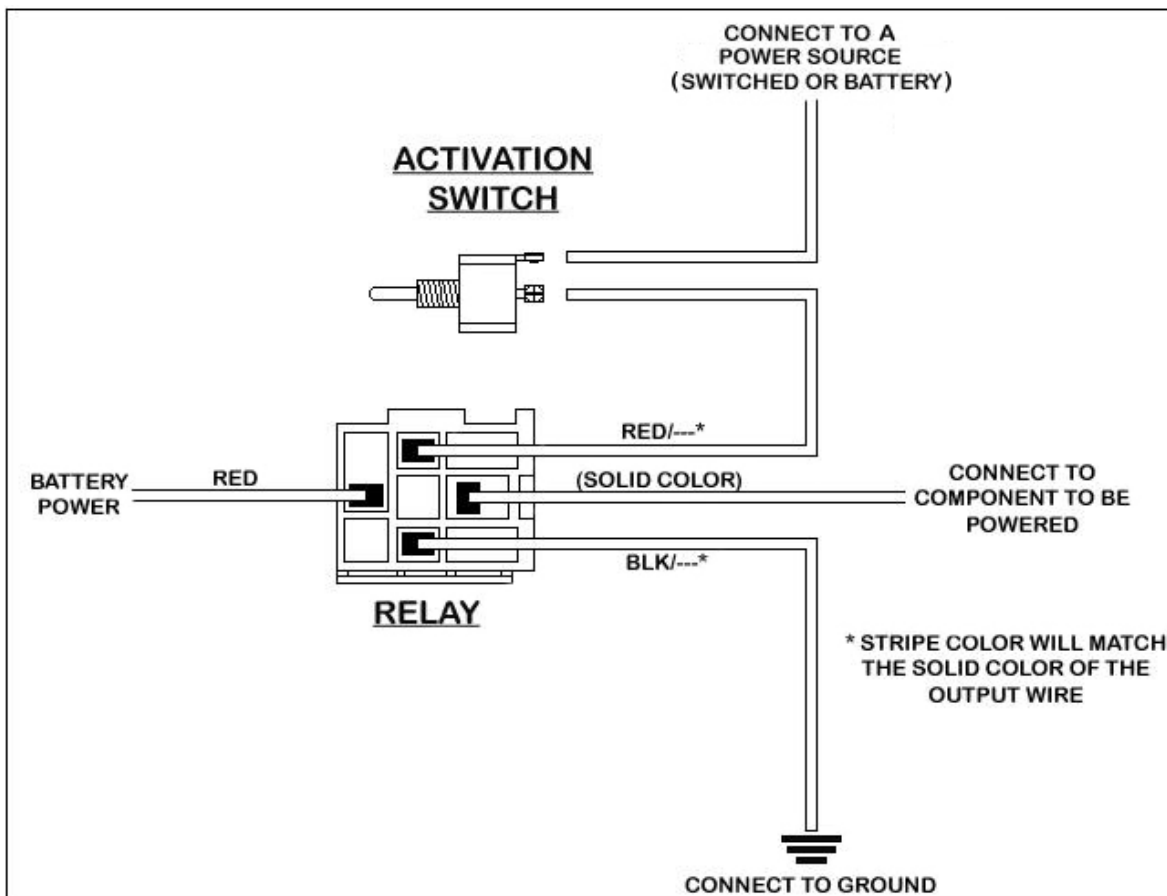

**Figure 1: Power Activated Relay**

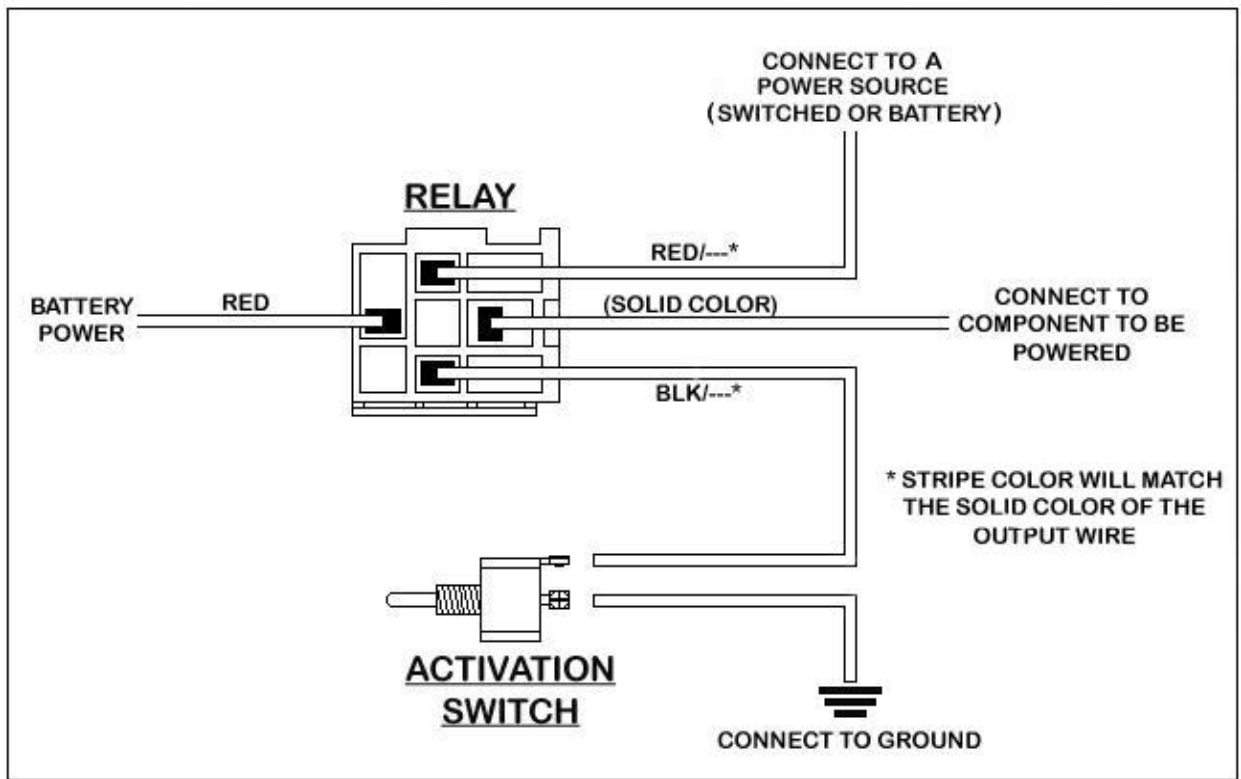

**Figure 2: Ground Activation**

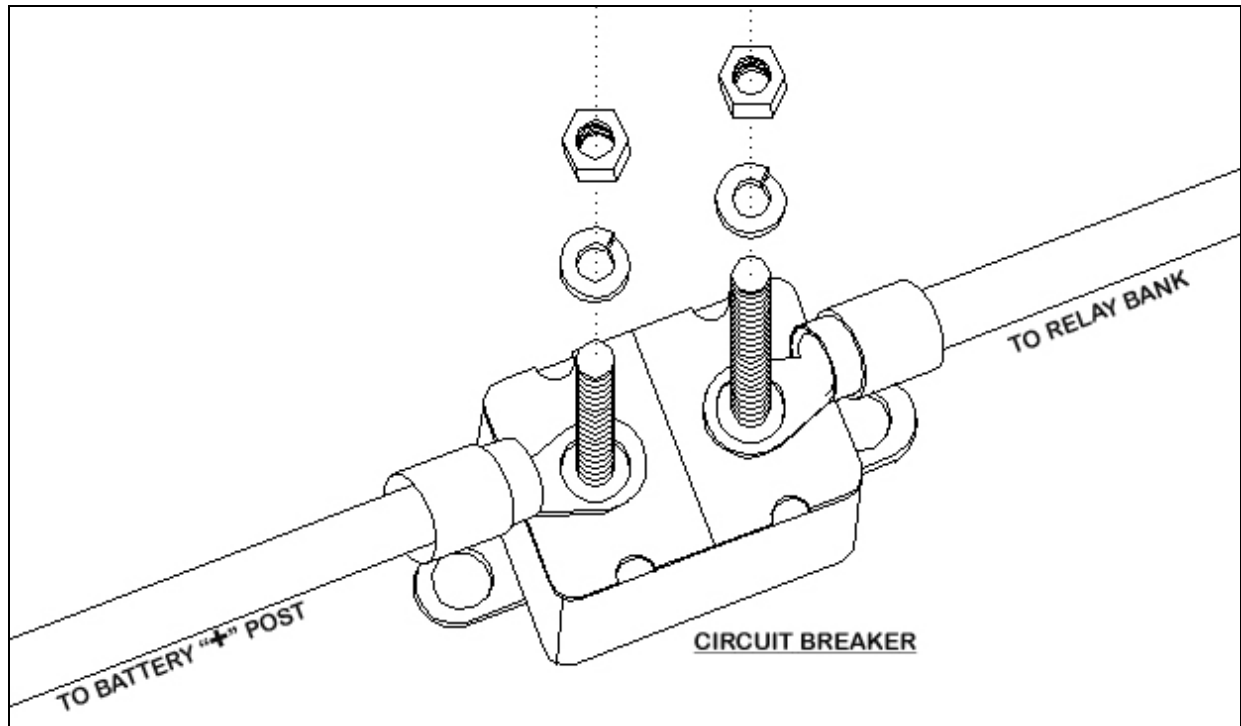

**Figure 3: Circuit Breaker**

## **Painless Performance Limited Warranty and Return Policy**

Chassis harnesses and fuel injection harnesses are covered under a lifetime warranty.

All other products manufactured and/or sold by Painless Performance are warranted to the original purchaser to be free from defects in material and workmanship under normal use. Painless Performance will repair or replace defective products without charge during the first 12 months from the purchase date. No products will be considered for warranty without a copy of the purchase receipt showing the sellers name, address and date of purchase. You must return the product to the dealer you purchased it from to initiate warranty procedures.