

PAINLESS

PERFORMANCE PRODUCTS Wire Harness Installation Instructions

**For Installing:
Part #50005 – 6 Switch / 8 Relay Race Car Kit
Manual #90562**



**Perfect Performance Products, LLC
Painless Performance Products Division
2501 Ludelle Street**

Fort Worth, TX 76105-1036

800-423-9696 phone · 817-244-4024 fax

Web Site: www.painlessperformance.com

E-Mail: painless@painlessperformance.com

We have attempted to provide you with as accurate instructions as possible, and are always concerned about corrections or improvements that can be made. If you have found any errors or omissions, or if you simply have comments or suggestions concerning these instructions, please write us at the address on the cover and let us know about them. Or, better yet, send us a fax at (817) 244-4024. We sincerely appreciate your business.

For Technical Questions

E-mail: tech@painlessperformance.com

Tech Line: 800-423-9696

Perfect Performance Products, LLC shall in no event be liable in contract or tort (including negligence) for special, indirect, incidental or consequential damages, such as, but not limited to, loss of property damage, or any other damages, costs or expenses which might be claimed as the result of the use or failure of the goods sold hereby, except only the cost of repair or replacement.

**P/N 90562 Painless Wiring Manual
1st Edition July 2008**

Copyright © 2008 by Perfect Performance Products, LLC.

TABLE OF CONTENTS

1.0	Introduction.....	1
2.0	About These Instructions.....	1
3.0	Tools Needed.....	1
3.1	50005 Contents.....	2
4.0	Pre-installation and General Harness Routing Guidelines.....	2
5.0	General Harness Installation Instructions.....	3
5.1	Grounding the Automobile.....	3
5.2	Rough Installation.....	3
5.3	Harness Attachment.....	3
5.4	Terminal Installation and Making Connections	4
6.0	General Circuit Connections.....	4
6.1	Cooling Fan.....	4
6.2	Late GM alternator.....	4
6.3	One wire alternator.....	4
6.4	Brake light Switch.....	5
7.0	Switch Panel Installation and Connections.....	6
7.1	Dash Mounting the Switch Panel.....	6
7.2	Roll Bar Mounting the Switch Panel.....	6
8.0	Wiring 12 pin connector.....	6
8.1	Optional Relayed Wire	7
8.2	Testing the System	9

3

LIST OF ILLUSTRATIONS

Figure 3.1	Roll Crimper needed.....	1
Figure 6.2	Late GM Alternator – Internal Regulator.....	5
Figure 6.3	One-Wire with Master Disconnect.....	5
Figure 8.0	Terminal insertions into connector method	6
Figure 8.1	50005 harness to switch panel connector chart.....	7
Figure 8.2	General Final Layout Guide.....	10
Figure 8.3	Optional Relay Kits and Accessories.....	11

LIST OF TABLES

Table 8.1	50005 Wire Connection Index.....	8
Table 8.2	Fuse Requirements.....	9

1.0 INTRODUCTION

You have purchased what we at Perfect Performance Products, LLC believe to be the most up-to-date and easiest-to-install automotive racing wire harness on the market. It is designed for easy installation, even if you have no electrical experience.

The 50005 fuse block can be easily attached to any under-dash location. There is enough wire length at all engine, dash, and trunk locations to complete the installation without splicing. The fuse block is pre-wired, allowing easy hookup. The proper fuses and relays have been pre-installed in the fuse block. In addition, all wires are color-coded and printed. This will help you identify the different circuits during installation and later on if additions to the overall system are necessary.

The **50005 Race Car Kit** was designed with two major groups incorporated into it:

Switch panel section: This section includes all of the wiring that will connect the switch panel to the relay bank and fuses. These wires are for the activation of the relays.

Accessory section: This section goes to the individual devices in the car. I.E. fuel pump, water pump, electric fans, starter, ignition system, etc.

2.0 ABOUT THESE INSTRUCTIONS

These instructions provide information for the installation of the 50005 6 Switch/ 8 Relay Racing Application Wire Harness Kit and the 6 Switch Panel. The contents of these instructions are divided into the following sections:

- 1.0 Introduction
- 2.0 About These Instructions
- 3.0 Tools Needed
- 4.0 Pre-Installation and Harness Routing Guidelines
- 5.0 General Installation Instructions
- 6.0 50005 racing application harness connections
- 7.0 Six Switch Panel Connections

Sections are further divided into Paragraphs and Steps. Throughout this instruction manual, the **Figure** numbers refer to **Illustrations** and the **Tables** that refer to information for installation. These are located in or near the sections or paragraphs to which they correspond. Always pay special and careful attention to any **Notes**, especially those in the Tables, and any text marked **CAUTION**.

3.0 TOOLS NEEDED

In addition to your regular hand tools, you will also need the following special tools:

1. Crimping tool for insulated terminals
(*Note: Use a quality tool to avoid over-crimping.*)
2. Crimping tool designed for rolled crimps.
3. Wire stripper
4. Volt/Ohmmeter
5. Electric drill
6. 1-1/4" Hole saw
7. Small (10 amp or less) battery charger



Illustration 3.1 Roll crimper Radio Shack P/N 64-2983 or equivalent

3.1 CONTENTS OF THE 50005 WIRE HARNESS KIT

Take inventory to see that you have everything you are supposed to have in this kit. If anything is missing, go to the dealer where you obtained the kit or contact Perfect Performance Products LLC at 800-423-9696. The 50005 6 Switch/8 Relay Race Car Kit should contain the following items:

The Main Wire Harness, with the Fuse Block pre-wired with fuses and relays installed

- 6 switch panel pre-wired and ready for install
- Connectors and terminals
- Firewall grommet
- 10ga red wire for alternator charge wire (rolled)
- 2 Packages of nylon tie wraps (1 pack of 4 inch and 1 pack 7-inch wraps)
- Parts bag, containing the Maxi fuse
- Race Car Wire Harness Installation Instructions P/N 90562 (This booklet)

4.0 PRE-INSTALLATION & HARNESS ROUTING GUIDELINES

The installation of your wire harness kit consists mainly of two parts:

- The physical routing, positioning, and securing of the wire harness, wire groups, and individual wires
- The proper electrical connection of the individual circuits.

These two major tasks are not separate steps, but are integrated together. That is, you will route some wires and make some connections, route some more wire and make some more connections. We cannot tell you how to physically route the harness in your automobile. The routing depends a great deal upon the particular make of automobile and to what extent you want to secure and conceal the harness. We do offer some general guidelines and routing practices starting in **Paragraph 4.1**, GENERAL installation instructions in **Section 5.0**, and precise instructions concerning the electrical connections you will make at the beginning in **Section 6.0**. To help you begin thinking through the installation of your wire harness, read the following sections:

- 4.1 Familiarize yourself with the harness by locating each of the harness sections in the following list. Decide where and how the Fuse Block and Switch Panel will be mounted. Painless Performance Wire Harness Kits are designed for the fuse block to be near the dash. You may choose to mount it in the X brace of the door, under the dash, or in dragster applications you may possibly mount it forward of the drivers compartment.
- 4.2 Decide which of the following circuits you will be using in your system and where the harness groups or wires will be routed. Most common routing is done along roll cage bars, A-pillars, door sills, or frame rails. A good exercise is to lay out the wire harness on the floor beside your automobile and identify all the wires and get a good idea of which wires are going to go where. ***If Power Braid has been chosen to sheath the harness it should be applied now! This will make the installation look clean and professional.*** (Refer at Figure 8.2 page 11 to view the Power Braid options). You will want to route the harness through and around open areas. Inside edges provide extra protection from hazards and also provide places for tie wraps, clips and other support.
- 4.3 Route the harness away from sharp edges, exhaust pipes, and hood, trunk, and door hinges. After the decision of proper routing has been determined, locate places to support the harness. Generally a support every 12 inches unless the harness routes under the floor carpet.
- 4.4 Allow enough slack in the harness at places where movement could possibly occur (body to frame, frame to engine, etc.). Make sure wire ends don't depend on the terminals to support the harness. The weight of the harness could cause terminals to disconnect. The wires should be bundled into harness groups. Use nylon ties, poly split loom, or tape to hold wire together. This will keep the installation clean and also keep wires from chaffing.

5.0 GENERAL INSTALLATION INSTRUCTIONS

5.1 GROUNDING THE AUTOMOBILE

A perfectly and beautifully wired automobile will nevertheless have problems if everything is not properly grounded.

***Note:** Painless Performance Wire Harness Kits include no ground wire except the black wire from the Switch Panel. You must supply ground wire (14-16 gauge) for all other circuits.*

Painless Performance suggests a 1gauge Ground Cable from the Negative Battery terminal to the automobile chassis frame. This will be your common ground point. From the same location route a 1gauge ground cable to the engine block. (DO NOT RELY UPON THE MOTOR MOUNTS TO MAKE THIS CONNECTION.) At this point a ground strap should be routed from the common ground point on the frame to the body. Painless Performance offers two different kits to make this installation effortless. The 40100 and 40105 will give the option of factory mount battery or remote mount battery locations.

If you have a fiberglass body, you should install terminal blocks to ground all your gauges, lights, and accessories. The terminal blocks work as remote grounding sources. Painless Performance offers the fiberglass body ground kit part # 40026 to make easy work of installing a remote grounding source.

5.2 ROUGH INSTALLATION

CAUTION: DISCONNECT THE POWER FROM YOUR VEHICLE BY REMOVING THE NEGATIVE BATTERY TERMINAL FROM THE BATTERY.

***Note:** Your kit comes equipped with a maxi fuse. This safety device is designed to go between wire #916 and the battery source for overall harness protection*

***Note:** Make no wire connections or permanent mounting of any kind at this time!*

Position the Fuse Block and Switch Panel in their intended locations. Drill a 1-1/4" (1.25") hole in the firewall near the fuse block for engine and headlight group wires to pass through (cooling fan, water pump, ect). Install the firewall grommet. Route engine and headlight group wires through the grommet and position the harness groups in the areas decided upon in **Paragraphs 4.2.**

***Note:** This grommet can also be used to pass your gauge sending unit wires or lines through.*

5.3 HARNESS ATTACHMENT

Note:** Harness routing and shaping will be a time-consuming task. Taking your time will enhance the beauty of your installation. Please be patient and **TAKE YOUR TIME!

Permanently mount the fuse block. Make sure that none of the wires are pinched or interfere with the Fuse/relay Block mounting

Mold harness groups to the contour of floor pan, firewall, fender panels, and any other area where wires or harness groups are routed. Remember to route the harness away from sharp edges, exhaust pipes, hood, trunk and door hinges, etc. Attach harness groups to your automobile with clips or ties starting at the fuse block and working toward the rubber grommet for the front groups and along the floor pan for the rear group. The dash wires should be routed out of the way of any under-dash obstacles, such as the cowl vent, radio, etc.

Note: Do not tighten tie wraps and mounting devices at this time. Make all harness attachments LOOSELY.

When used every 1-1/2" or so on the visible areas of the harness, the 4-inch wire ties make a very attractive assembly. A tie installed in other areas every 6" or so will hold the wires in place nicely.

5.4 TERMINAL INSTALLATION AND MAKING CONNECTIONS

Note: In the following steps you will be making the circuit connections. Before you start, you should carefully read Sections 6.0 through 7, and continually refer to the wire connection indexes, DOUBLE CHECKING your routing and length calculations before cutting any wires and making connections. Give special attention to leave slack in the wire for connecting and disconnecting in the future.

BEFORE YOU START:

Have all needed tools and connectors handy.

Select the correct size terminal for the wire and stud application.

Determine the correct wire length and cut the wire. Remember to allow enough slack in the harness and wires at places where movement could possibly occur, such as automobile body to frame, frame to engine, etc. Double check your calculations.

Strip insulation away from wire. Strip only enough necessary for the type of terminal lug you are using.

Note: In the following step, make sure that the terminal is crimped with the proper die in the crimping tool. An improper crimp will NOT make a good connection. DO NOT OVER-CRIMP! Crimp the terminal onto the wire. Connecting the harness throughout the groups is a repeating process.

Make sure that each wire is FIRST properly routed and THEN attach. **DO NOT ATTACH THE WIRE FIRST AND THEN ROUTE AFTERWARD.** When all wires are attached, tighten the mounts and ties to secure harness permanently.

6.0 50005 GENERAL CIRCUIT CONNECTIONS

6.1 Cooling Fan

A circuit breaker has been included in this kit to protect the system from any voltage spikes that may occur during fan start up. The circuit breaker should be wired inline with the **gray/white 901** wire, as close to the fuse/relay block as possible.

6.2 Late GM Alternator (after 1972) Internal Regulator. See Figure 6.2.

- A. Connect ENGINE SECTION ignition hot (I.E. a branch off of the 931 pink wire) to alternator terminal #1. Connect ENGINE SECTION wire (red) (shown in diagram 6.2 on page 5) to the alternator output lug (Bat).
- B. Connect a short 10-gauge jumper wire from alternator terminal #2 to the alternator output lug (Bat).
- C. A connector and terminal spades for late GM Alternators are included in the parts bag.

6.3 GM One-Wire Alternators

- A. Connect an 8gauge wire to the Alternator Output lug then route to the B+ side of the starter. No wires will be attached to the 1 or 2 posts
- B. When using a Delcotron1-wire alternator you must use a voltmeter. A warning light cannot be wired in. A warning light may be used when using a Painless PowerStar alternator.

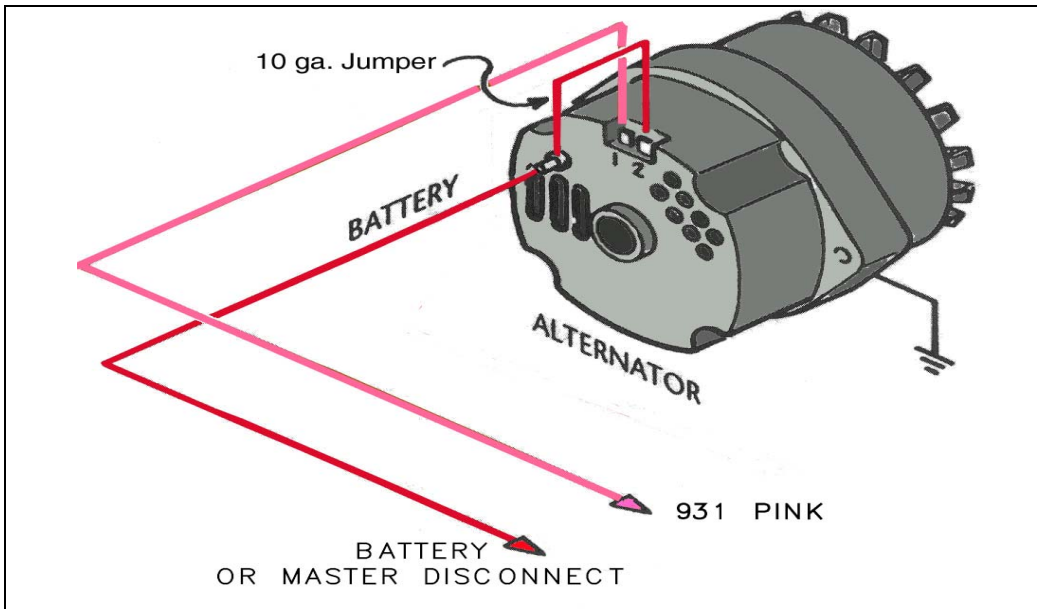

Figure 6.2 Late GM alternator with internal regulator

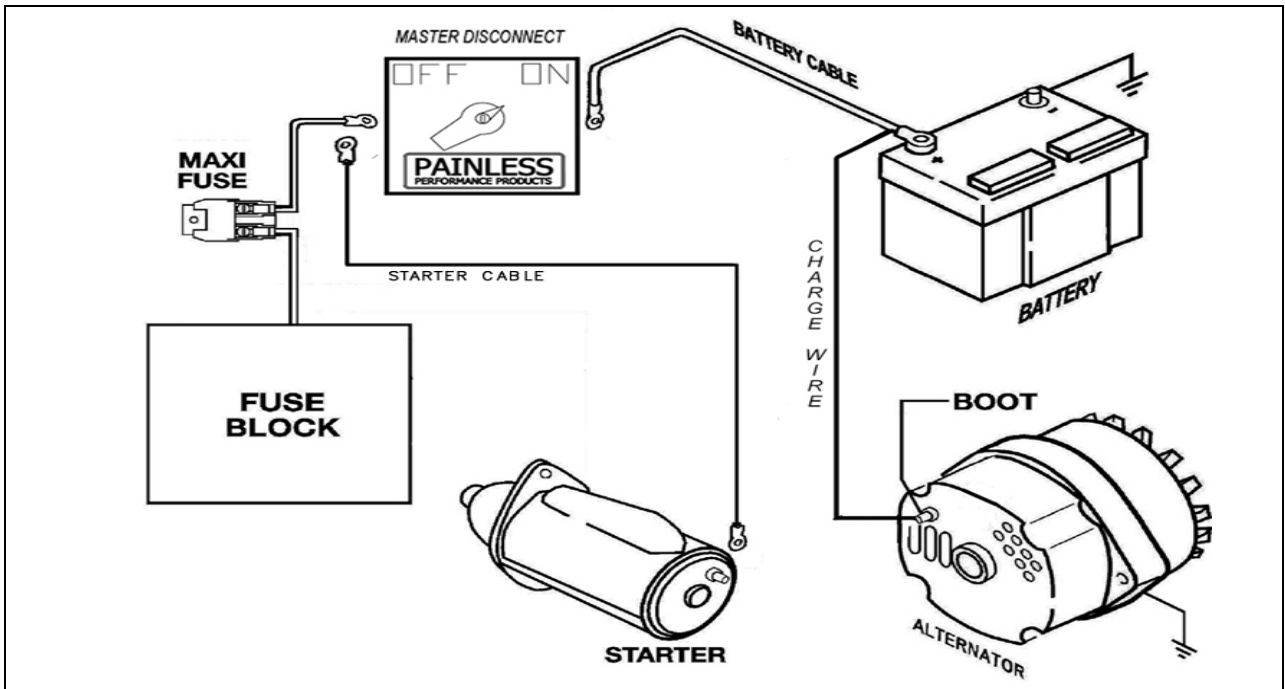

Figure 6.3 One-wire with Master Disconnect

Note: Your Alternator may not appear exactly as represented in the **Figures**, but the circuits are wired the same.

Note: When using an alternator in a racing application most sanctioning bodies require the charging system to be wired so that when you shut off the master switch at the back of the car the power to the entire car will be shut down. Refer to the full schematic shown above.

6.4 Brake Light Switch

A brake light as required by some classes, use the #954 white wire to supply power to the brake

switch. A wire from the brake switch to the lights at the back of the car will need to be added to the installation. This wire may also be used to power a delay box. **DO NOT** power delay box off of a relay.

7.0 SWITCH PANEL INSTALLATION AND CONNECTIONS

Note: See figure 8.0 for the correct method of terminal insertion into the connectors.

7.1 Dash mounting the switch panel.

- A. Mount the Switch Panel in the desired location by drilling holes in the dash to suit your needs. When dash mounting this switch panel you will not use the provided switch panel rear cover. Four (4) mounting screws are provided. Be sure you have threaded the wires through any holes and grommets before installing the connectors. The electrical contacts are almost impossible to remove without damage once they have been inserted into the connector body.

7.2 Roll bar mounting the switch panel.

The switch panel chassis has been designed for large hose clamps to be routed through the back and around the roll bar for easy mounting.

Note: The box is pre-punched to allow the switch panel wires to exit from any chosen side.

The rubber grommet is provided to protect the wires as they exit from the box. Cap plugs are included to plug the remaining unused holes.

Attach the switch panel to the box with the four (4) screws provided, routing the wires through the grommet and out the desired hole. Be sure you have threaded the wires through any holes and grommets before installing the connectors. The electrical contacts are almost impossible to remove without damage once they have been inserted into the connector body.

8.0 WIRING 12 PIN CONNECTOR.

The fuse/relay box connector will come pre-wired. After you determine the location that the switch panel will be mounted you will now know how much length will be needed to make connection between the fuse/relay box and the switch panel. After deciding length start stripping the wires and terminating switch panel pigtail. Make sure the correct wires are applied to the specific pinhole that is specified.

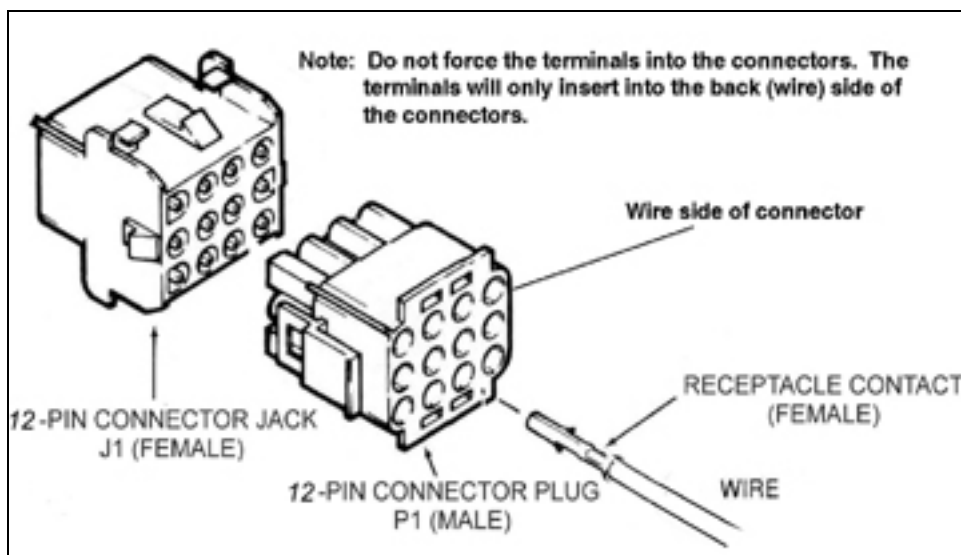

Figure 8.0 Terminal insertions into connector method

View is from wire side of connector.

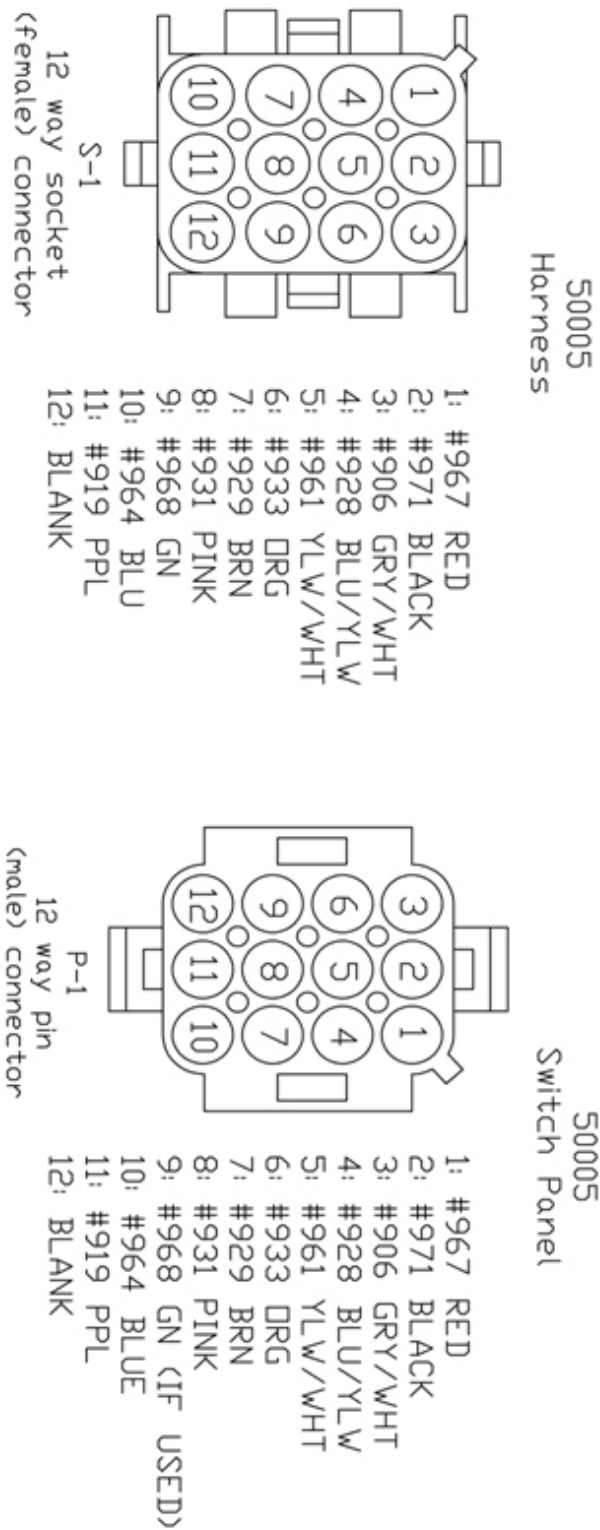

Figure 8.1 50005 harness to switch panel connector chart

8.1 OPTIONAL RELAYED WIRE

Green 968 is a power-activated wire for accessory 2 relay. The circuit is pre-wired from the fuse block to the S1 connector. If the circuit is needed, terminate the wire and insert terminal in the #9 cavity in the P-1 connector. The circuit is now ready to wire to the device desired. The accessory switch will activate the circuit. This can be used for line locks, nitrous, Trans brake, etc. (20amp max circuit)

WIRE CONNECTION INDEX				
ACCESSORY SECTION B+				
Color	Ga.	No.	Connect To	Function
Red	8	916	Battery Source	Harness Power
Black	12	960	Ground	Harness Ground
Purple	10	970	Starter Solenoid START	Starter Solenoid Activation
Gry/Wht	12	901	Cooling Fan	Cooling Fan Power
Ylw/Wht	12	947	Fuel Pump	Fuel Pump #1 Power
Green	14	963	ACC. relay	ACC relay #2
Brown	16	926	Tail Lights	Tail Lights Power (Not Relayed)
Blu/Ylw	14	907	Headlights	Headlights Power
Blue	14	962	Water Pump	Water Pump Power
Pink	14	920	Ignition Coil	Ignition Power
Orange	14	969	Accessory	Accessory Power
White	14	954	Brake Light or Delay Box	Supply Power for Brake Lights or Trans Brake Delay Box
INSTRUMENT PANEL SECTION				
Color	Ga.	No.	Connect To	Function
Red	14	967	Switch Power	B+ Power for Switches
Brown	16	929	Headlamp Sw. (Tail)	Tail Lights Power
Orange	18	933	Ignition Sw. Accy.	Accessory Relay Activation
Ylw/Wht	18	961	Fuel Pump Switch	Fuel Pump Relay Activation
Green	18	968	ACC. #2 Switch	ACC. #2 Relay Activation
Blue	18	964	Water Pump Switch	Water Pump Relay Activation
Pink	18	931	Ignition Sw. RUN	Ignition Relay Activation
Gry/Wht	18	906	Cooling Fan Switch	Cooling Fan Relay Activation
Purple	18	919	Ignition Sw. START	Start Relay Activation
Blu/Ylw	18	928	Headlamp Sw. (Head)	Headlight Relay Activation
Black	18	971	Switch Ground	Ground for Switches
NOTES:				
1. 2-color wires: 2 nd color (stripe) may not be intense color. Observe two-color wires closely.				
2. Wire has PRINT TO IDENTIFY THE DESTINATION.				

Table 8.1 50005 Wire Connection Index

FUSE REQUIREMENTS

Switches.....	10
Ignition.....	30
Accessory.....	15
Electric Fuel Pump #1.....	20
Accessory #2.....	20
Electric Cooling Fan.....	15
Electric Water Pump.....	15
Lights.....	20

Table 8.2 Fuse Requirements

8.2 TESTING THE SYSTEM

CAUTION: IF YOU HAVE NOT YET DISCONNECTED THE BATTERY FROM THE AUTOMOBILE, DO SO NOW! DO NOT CONNECT THE BATTERY CHARGER WITH THE BATTERY CONNECTED. YOU WILL SIMPLY DEFEAT THE PURPOSE OF USING THE CHARGER.

Use a small (10 amp or less) battery charger to power up the vehicle for circuit testing. If there is a problem anywhere, the battery charger's low amperage and internal circuit breaker will provide circuit protection. Connect the battery charger's NEGATIVE output to the automobile chassis or engine block and its POSITIVE output to the automobile's positive battery terminal.

Individually turn on each light, ignition, wiper circuit, etc, and check for proper operation. When all circuits function properly, attach the battery cable to the battery for vehicle operation

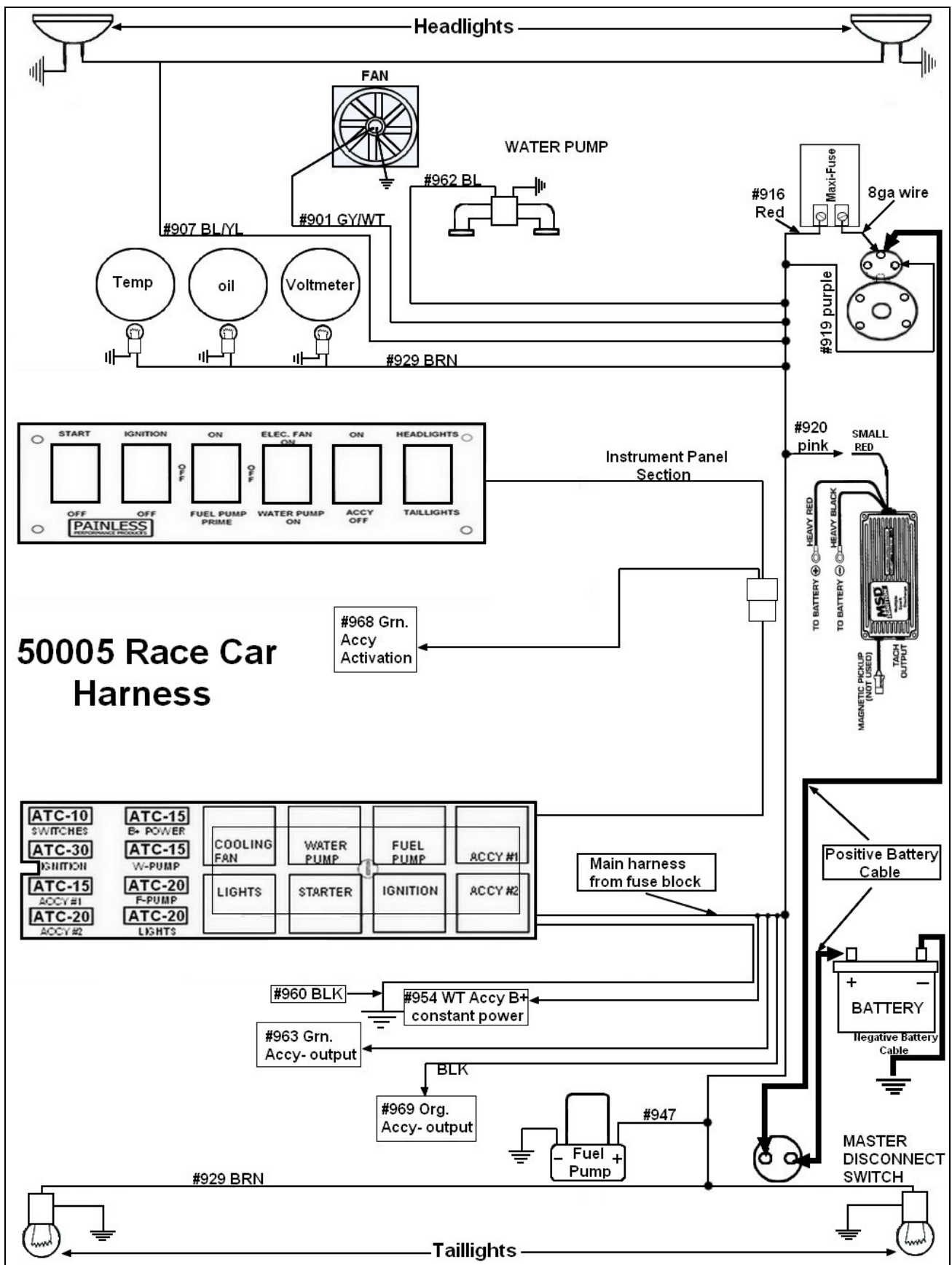

Figure 8.2 General final layout guide

POWERBRAID WIRE WRAP

Protect and clean up any harness installation with our new braided wire wrap. Laterally split design closes around wire bundle without the need for additional taping or fasteners. Available in black only.

Powerbraid Wire Wrap

- #70901 1/4" Diameter, 20 ft.
- #70902 1/2" Diameter, 10 ft.
- #70903 3/4" Diameter, 6 ft.
- #70904 1 1/2" Diameter, 4 ft.
- #70920 Chassis kit

Accessories:

- | | |
|--------------------------------------|----------------------------------|
| Safety charge wire kit | #30711 |
| Remote Battery junction | #40106 |
| Junction Block | #80112 |
| Fiberglass body grounding kit | #40026 |
| Universal Integrated Turn Signal Kit | #30120 |
| Master Disconnect Switch | #50710 w/ plate #80140 w/o plate |
| Magneto Shutdown relay | #50104 |

Figure 8.2 Optional relay kits and

**Painless Performance Limited Warranty
And Return Policy**

Chassis harnesses, fuel injection harnesses, and Striker Cold Shot units are covered under a lifetime warranty.

All other products manufactured and/or sold by Painless Performance are warranted to the original purchaser to be free from defects in material and workmanship under normal use. Painless Performance will repair or replace defective products without charge during the first 12 months from the purchase date. No products will be considered for warranty without a copy of the purchase receipt showing the sellers name, address and date of purchase. You must return the product to the dealer you purchased it from to initiate warranty procedures.

Notes