

PART# 640117
2017 Ford F150 Raptor
AR3 Exhaust System

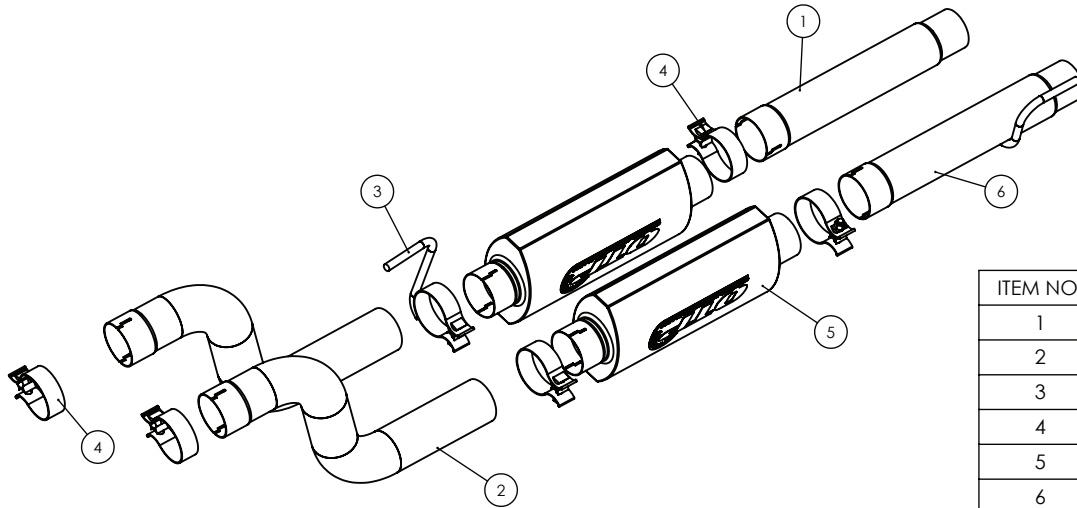

Caution! Never work on a hot exhaust system. Burns or other serious injuries can result. Always allow the exhaust system to cool before removal. Always consult vehicle manual for proper lifting and support guidelines. Always wear approved safety glasses when working. Serious injury or death can result if safety precautions are not followed.



ITEM NO.	DESCRIPTION	QTY.
1	LEFT INTERMEDIATE TUBE	1
2	OVER AXLE TUBE	2
3	CLAMP HANGER ASSEMBLY	1
4	3.00 TORCA ACCUSEAL CLAMP	5
5	3.00 AR3 MUFFLER - NOTCHED	2
6	RIGHT INTERMEDIATE PIPE ASSEMBLY	1

Removal of factory equipment:

Step 1: Raise and support Vehicle. At the rear of the factory resonator pipe, loosen the factory accuseal clamp and the factory coupler clamp. Also loosen the two accuseal clamps where the over axle tubes meet the muffler above the rear axle.

Step 2: Using a pry tool or hanger seperator tool, remove the factory hangers from there rubber isolators. Use a spray lubricant to make hanger removal easier.

Step 3: Seperate the stock muffler assembly from the stock exit pipes. With everything undone remove the factory muffler assembly from the vehicle. Save the factory coupler clamp as it will be reused.

Installation of new exhaust

Step 4: Slide the factory coupler clamp onto th reduced end of the left inermediate tube, place an accuseal clamp on the other end and place it onto the driver side of the factory resonator pipe. Do not tighten any clamps at this time.

Step 5: Slide the reduced end of the right intermediate pipe into the passenger side of the factory resonator. Slide the hanger into the rubber isolator. Then place an accuseal clamp on the expanded end of the tube. Do not tighten any clamps at this time.

Step 6: Slide an AR3 muffler onto each intermedaite tube, orient the mufflers as shown in the diagram. Place the clamp hanger on the driver side muffler and an accuseal clamp on the passenger side muffler. Slide the clamp hanger into the factory rubber isolator.

Step 7: Slide an accuseal clamp onto the expanded end of each over axle tube then insert an over axle tube into each muffler.

Step 8: With the over axle tubes installed, slide the factory exit pipes into the over axle tubes. Align the exhaust tips to the rear bumper. Then starting at the front of the vehicle and working towards the back tighten all clamps.

Note: After initial startup a small trace of smoke may be visable from the exhuaust, do not be concerend. This is from residual oils left in the tube from the manufacturing process and will disipate quickly.

Quick Time Perfornace recomends professional installation on all of our products.

Made in the USA