

# INSTALLATION INSTRUCTIONS

## FUEL RAIL FOR MZR AND DURATEC ENGINES

Support: [info@radiumauto.com](mailto:info@radiumauto.com)

Document# 19-0212

**WARNING: DO NOT EXPOSE WORK AREA TO ANY SPARKS OR FIRE. DO NOT SMOKE WHILE OPERATING ON THE FUEL SYSTEM. CLEAN UP ALL FUEL SPILLS IMMEDIATELY. WORK IN A WELL VENTILATED AREA.**

1. If accessible, refer to the factory service manual for disassembly questions.

To relieve fuel pressure, temporarily disconnect the fuel pump connector or remove the fuel pump fuse. Start and idle the vehicle and allow the engine to stall. Turn the ignition OFF and remove the key.

Install fender covers to protect the paint and body. Remove the engine and battery covers.

Using a 10mm wrench, disconnect the (-) negative terminal (shown right).



2a. Find the OEM fuel rail feed line. The image depicts the location difference between the MZR and Duratec fuel rails. Also, reference the following pictures for further clarity. Both fuel rails use a SAE quick connector.

After the engine has cooled, place shop towels down under this area.

*NOTE: SAE connectors will vary from engine to engine. Some require a plastic protective cover to be unsnapped first. Others may require a special tool that can be found at most auto part stores. Some require the SAE locking tabs to be squeezed and simultaneously pull away from the connection.*



### 2b. Mazda MZR engines only

This connection will be in the front of the fuel rail pointing away from the engine (shown in red).



### 2c. Ford Duratec engines only

The SAE connector will be at the rear of the fuel rail (shown in purple).

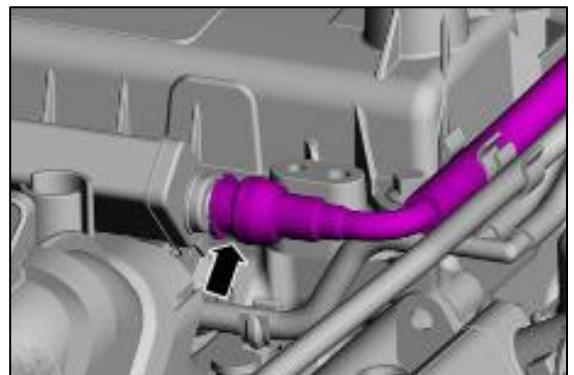

3. Unplug the 4 fuel injector connectors by squeezing the locking tabs.

Next, remove the 2 mounting bolts using a 10mm socket, as shown.



4. Carefully pull the fuel rail assembly away from the cylinder head to dislodge. The fuel injectors should remain attached to the fuel rail. Place on a workbench and catch any fuel that drips out.

NOTE: Do not misplace the lower injector O-rings as they might not have come out of the cylinder head ports.

Drain any excess fuel into a safe container for disposal. Thoroughly clean out any dirt or debris found in the cylinder head ports with engine oil.

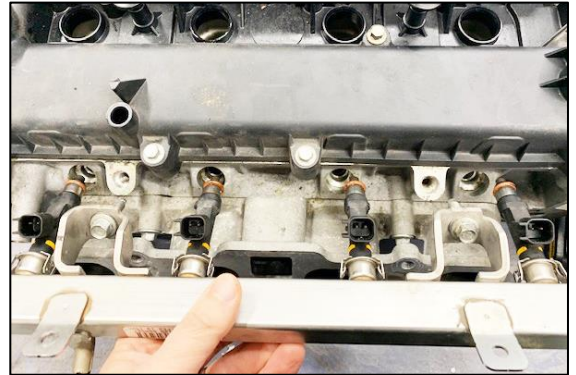

5. One by one, carefully unclip the fuel injectors from the OEM fuel rail, as shown.

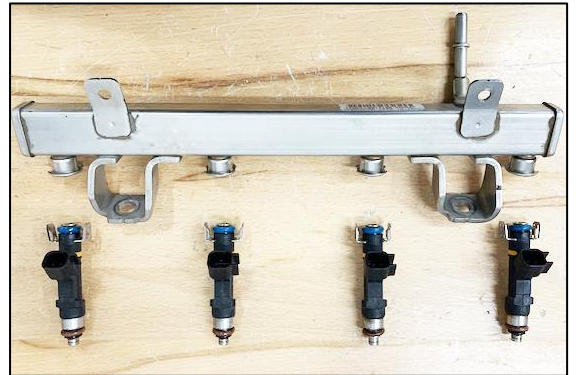

6. The 4 OEM fuel injector locking clips will be reused.



#### 7a. Mazda MZR engines only

Lubricate all adapter fitting O-rings and secure to the four 8AN ORB ports.

NOTE: If installing Radium Engineering 20-0503-PK into a Mazda MZR engine, fix the included fittings to the ports exactly as depicted. This will permit the OEM fuel system to be retained.

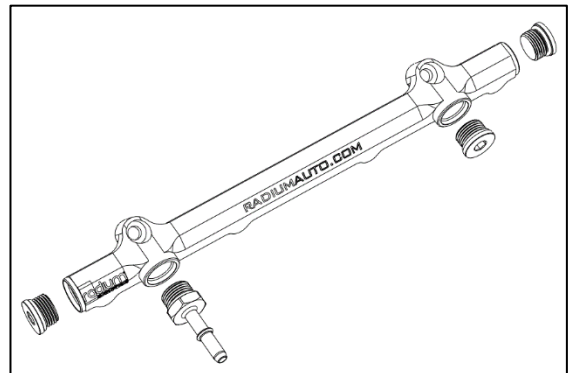

7b. **Ford Duratec engines only**

Lubricate all adapter fitting O-rings and secure to the four 8AN ORB ports.

NOTE: If installing Radium Engineering 20-0503-PK into a Ford Duratec engine, fix the included fittings to the ports exactly as depicted. This will permit the OEM fuel system to be retained.

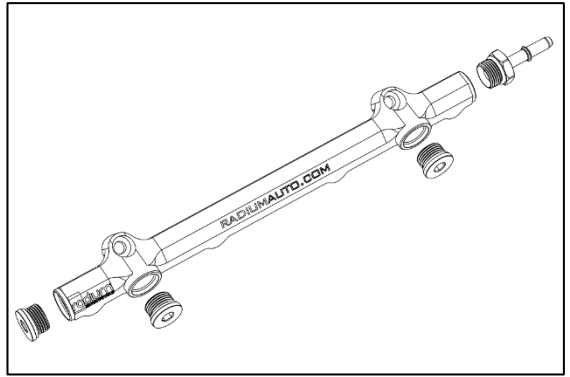

8. Lubricate each fuel injector's top O-rings with engine oil. Fully insert the fuel injectors into the Radium fuel rail injector ports. If reusing OEM or compatible fuel injectors, slide the OEM injector clips on locking them to the fuel rail.

Press the 2 included thermal insulating spacers into the underside of the fuel rail mounts. Position the fuel rail assembly onto the cylinder head.

Insert the 2 thermal insulating washers to the underside of the 2 mounting bolt heads.



9. Torque the bolts to 10 ft-lbs (13.6Nm) using a 6mm Allen hex wrench.

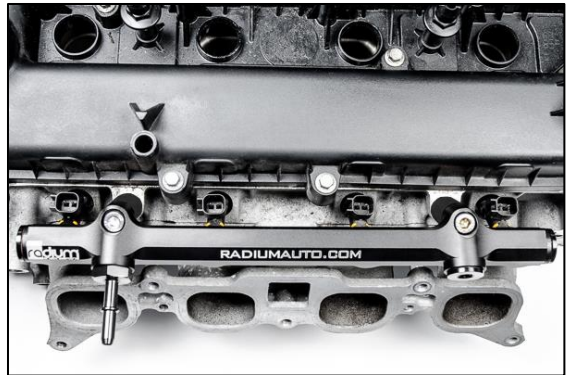

10. As a test, push the fuel injectors downward until they bottom out. Now inspect the injectors' upper O-rings and confirm they are still inserted into the fuel rail injector bores. Do not pressurize the fuel system until the proper height is achieved.

Orientate the fuel injectors such that the electrical connectors do not experience any interference with the surrounding area. Plug in each of the injector connectors.

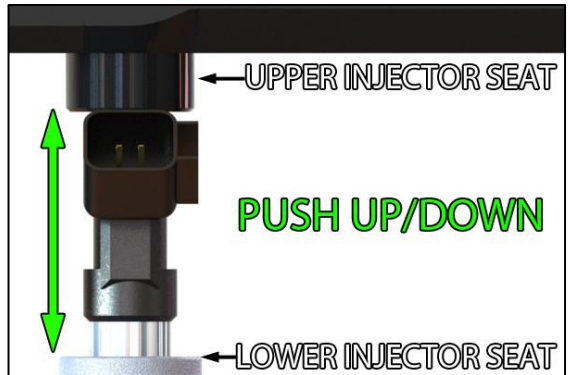

11. After everything is reinstalled in a reverse order, cycle the key a few times (without starting engine). This allows the fuel pump to prime the system. CHECK FOR LEAKS! If no leaks are found, start the engine and check for leaks again while the engine is running.

**Installation Complete**

NOTE: OEM fuel pressure: 3.8 Bar (+/- 0.2).

