



www.skyjacker.com

# 2012 Polaris Ranger 800 XP / Crew Rear Winch Mount Installation Instructions

## REQUIRED TOOL LIST:

- Safety Glasses
- Standard Wrenches & Sockets
- Drill & Assorted Drill Bits
- Torque Wrench



Before beginning the installation, thoroughly & completely read these instructions. Please refer to the Parts List to insure that all parts & hardware are received prior to the disassembly of the vehicle. If any parts are found to be missing, contact SKYJACKER<sup>®</sup> Customer Service at 318-388-0816 to obtain the needed items. If you have any questions or reservations about installing this product, contact SKYJACKER<sup>®</sup> Technical Assistance at 318-388-0816.

## Component Box Breakdown:

### Part #: RWM101

Item #	Description	Qty
P12RWM-B	10-12 POL RGR REAR WINCHMT	1
HB-RWM101	HDWR BAG: RWM101 WINCHMT	1

Item #	Description	Qty
I-RWM101	INSTRUCTION SHEET: RWM101	1

## Hardware Bag Breakdown:

### Part # HB-RWM101

Item #	Description	Qty
CS2875	CRUSH SLEEVE / 2.875"	2
38X114FTB	3/8 X 1 1/4 FINE THREAD BOLT	2
38X412FTB	3/8 X 4 1/2 FINE THREAD BOLT	2

Item #	Description	Qty
38FTN	3/8-24 FINE N/I LOCK NUT	4
38SAEW	3/8 SAE WASHER	8

## Installation:

1. With the vehicle on flat level ground, set the emergency brake, & block the front & rear tires / wheels.
2. Using the rear OEM upper A-arm bolts as a guide, align the two larger holes of the new Skyjacker rear winch mount with the rear OEM upper A-arm bolts.

3. Install the new Skyjacker upper crush sleeves (Part # CS2875) between each rear frame rail & install the new Skyjacker rear winch mount using the supplied 3/8" x 4 1/2" bolts, washers, nuts, & a 9/16" socket. (See Photo # 1)
4. Mark, center punch, & drill the new lower mounting locations for the new Skyjacker rear winch mount using a 3/8" drill bit.
5. Once drilled, finish installing the new Skyjacker rear winch mount to the vehicle using the supplied 3/8" x 1 1/4" bolts, washers, nuts, & a 9/16" socket. (See Photo # 1)
6. Unblock the front & rear tires / wheels, & release the emergency brake.

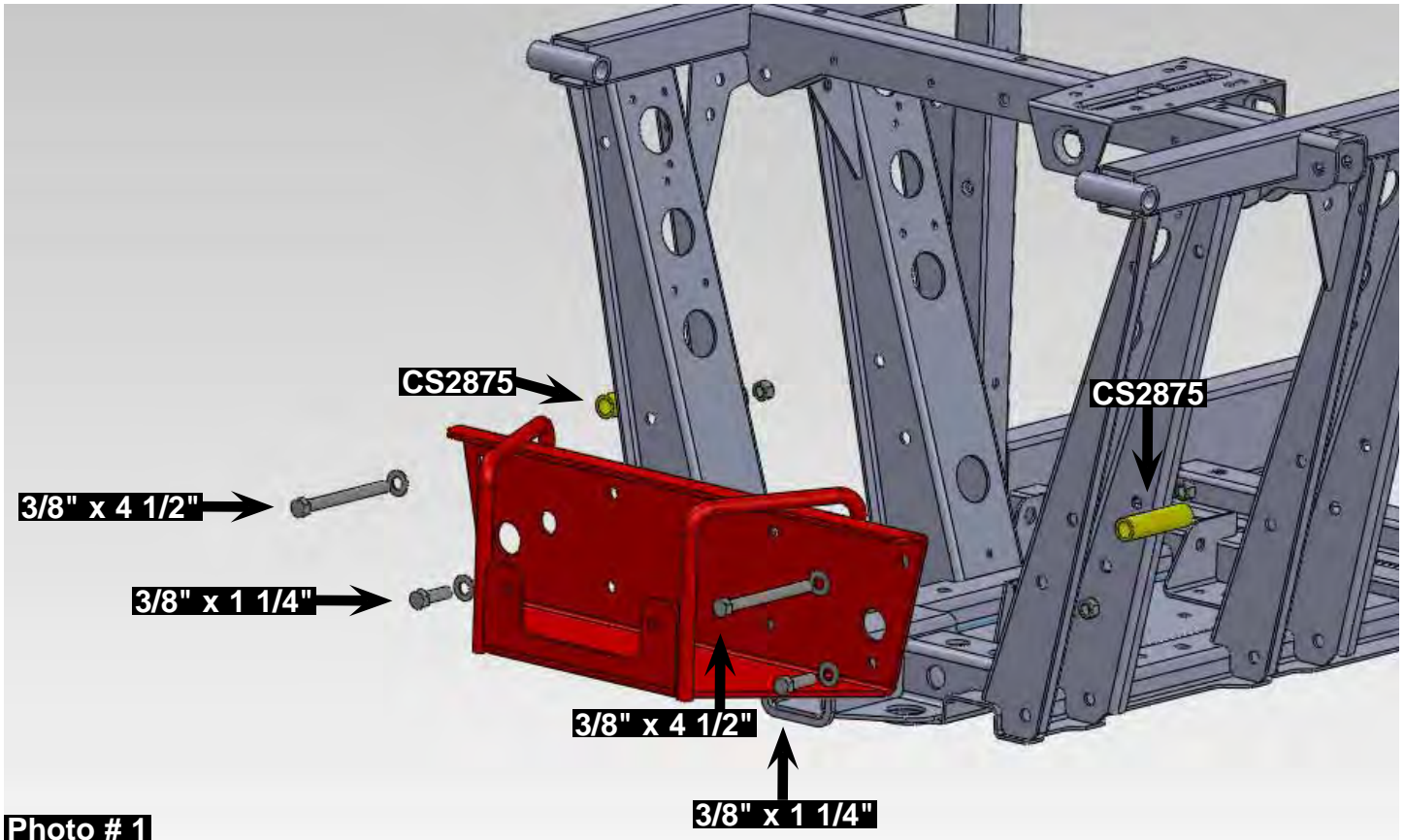

**Photo # 1**

**FINAL NOTES:**

- After the installation is complete, double check that all nuts & bolts are tight.
- Retorque all the bolts after the first 100 miles.
- The exhaust may discolor the powder coat of the rear winch mount. This is not a fire hazard & will not affect the functionality of this rear winch mount.

**Seat Belts Save Lives, Please Wear Your Seat Belt.**