



VALUE KIT
Part # WK20 or XK20
'05-'06 Jeep Grand Cherokee
2006 Jeep Commander



Bill Of Material		
Part No.	Description	Qty.
CS3648COIL SPACER	2
CS3649COIL SPACER	2
CS3650COIL SPACER	2
CS3651COIL SPACER	2
SM10976-LR	...STRUT MOUNT	2
W10138SPECIAL WASHER,WK20/XK20	4
SC3672STEM CUSHION FOR WK20,XK20	4

1. Read instructions completely, check bill of materials to ensure all parts were received.
2. Disconnect negative battery cable.

Front Installation

3. On the passenger's side: Remove the coolant reservoir mounting bolts and move the coolant reservoir off to the side. Remove upper passenger's side shock mounting nuts
4. On driver's side: Remove the three nuts to the power distribution center. Remove upper driver's side shock mounting nuts
5. Raise vehicle until front tires are clear, support the vehicle.
6. Remove the front tire and wheel assembly
7. Remove the lower stabilizer link bolt and move sway-bar assembly out of way.
8. Pull ABS sensor wire from the spindle and tie it up to keep it from getting damaged. (See Fig. 1)
9. Remove the upper ball joint nut.
10. Separate the upper ball joint from the spindle.
11. Remove the shock absorber clevis bracket bolt.
12. Remove the strut assembly.
13. Mark each strut assembly orientation so that they can be reassembled easily.
14. Compress the strut assembly with a wall mounted coil spring compressor so that the coil spring has about 1/2" play in the strut and remove the upper strut isolator mount nut. (See Fig. 2)
15. Pop the OE bolts out of the upper shock mount and press them back into the SM10976-LR. (See Fig. 3)
16. Reassemble the strut. Check the diagram 1-EXPLODED STRUT and 2-CUT-AWAY STRUT on page 3.
17. Install the struts back into place and install everything from steps 11 to 3.

Rear Installation

18. Remove the rear tire and wheel assembly
19. Remove rear sway-bar bolt and swing the bar and linkage out of the way. Remove the rear upper shock bolts and move the shocks clear of the way.
20. Remove the spring from the passenger's side of the vehicle. Pull the jounce bumper, the OE upper isolator and take out the jounce bumper cup.
21. Insert the jounce bumper cup into the upper coil Isolator and bolt the two into place. Put jounce bumper and spring back. (See Fig. 4, 5)
22. Remove the Driver's side rear spring. Note: the rod-style spring compressor will make removal and installation possible.
23. Install the Coil spacer and jounce bumper cup.
24. Place the jounce bumper inside the coil spring right-side up and install the spring.
25. Install the sway-bar, shock absorbers and rear wheels.
26. Torque all bolts to factory specs and check after 50 miles.

SKYJACKER®

THE BEAR OF SUSPENSIONS

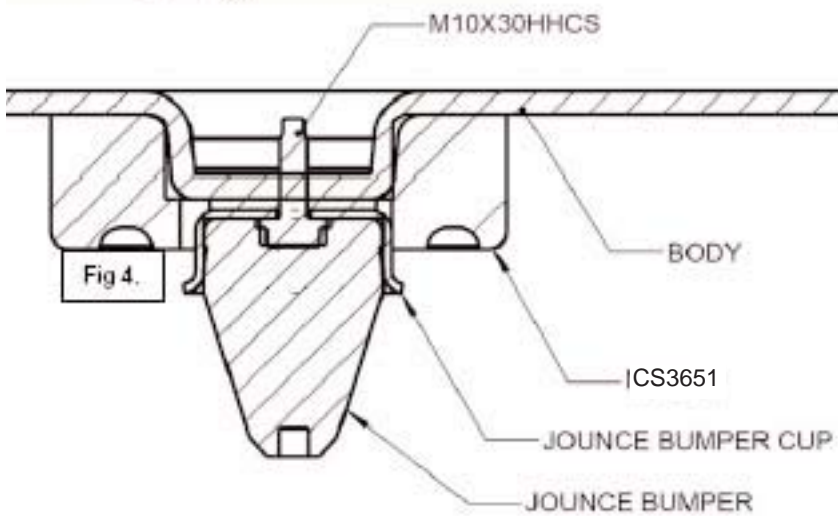
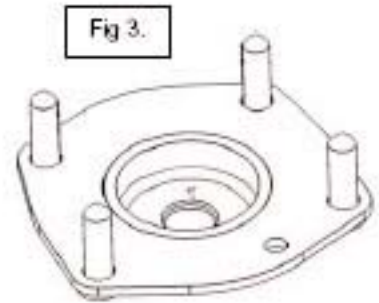
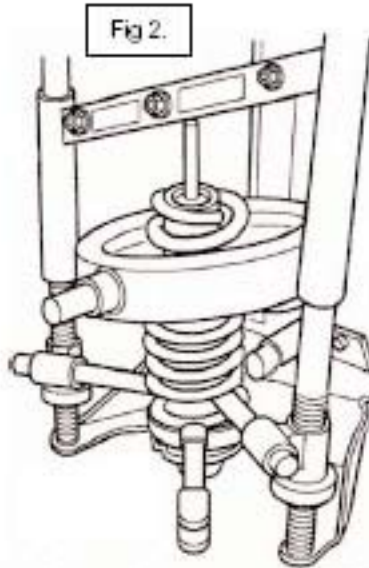
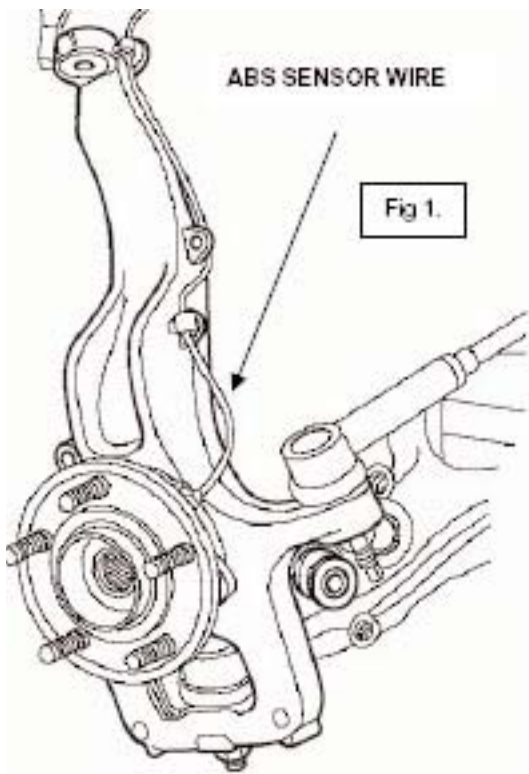

SKYJACKER®

THE BEAR OF SUSPENSIONS

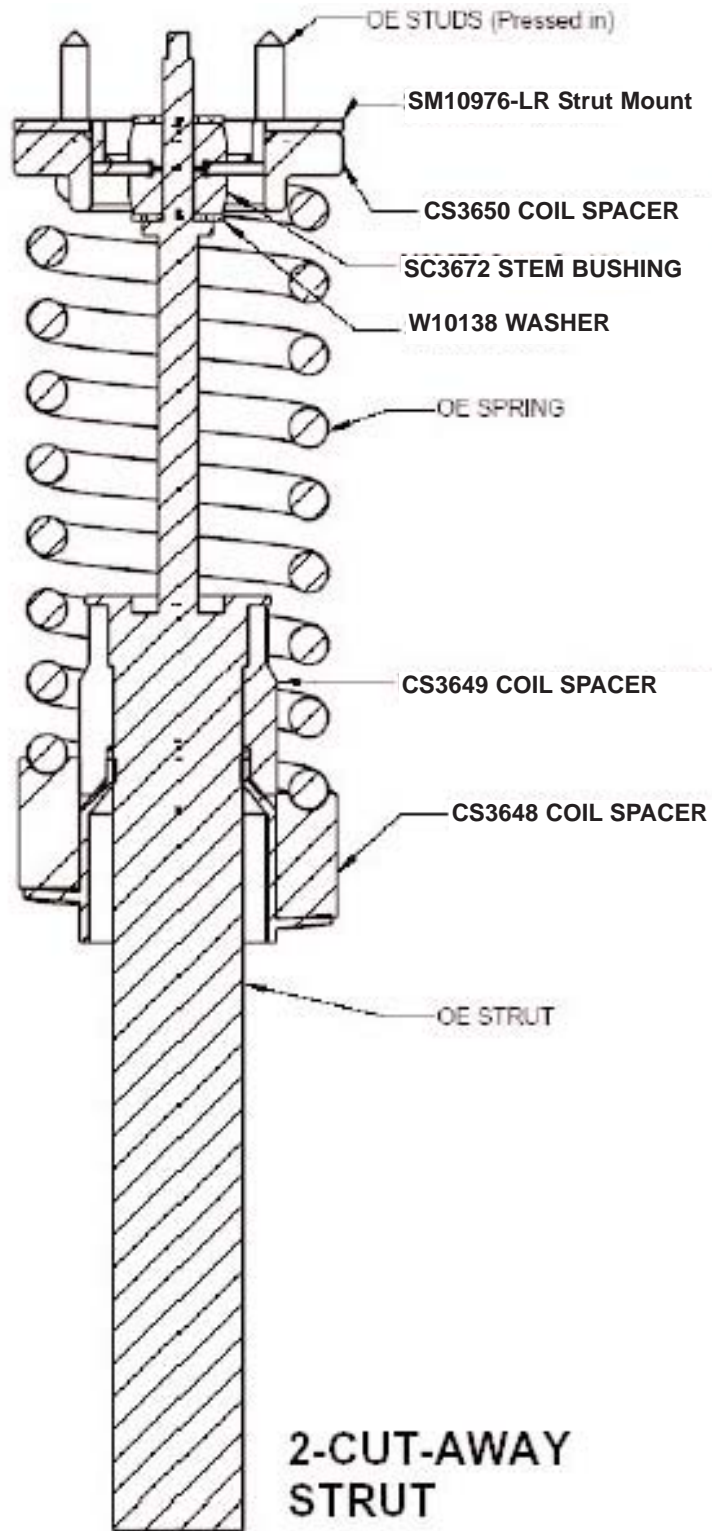
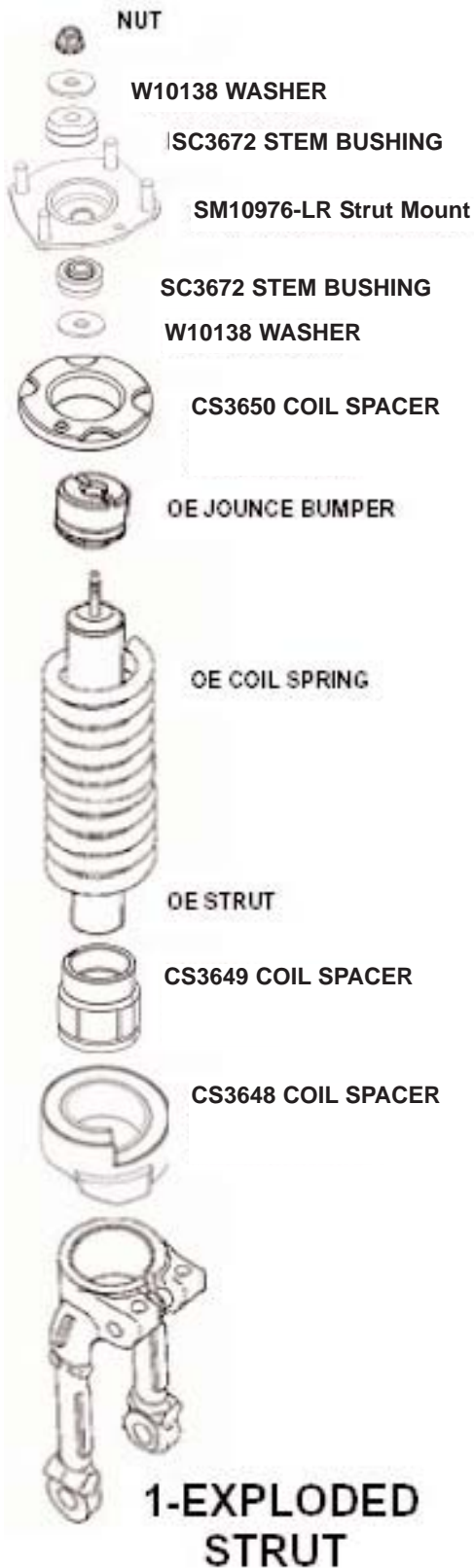



ALIGNMENT SPECS

FRONT AXLE	SPECIFICATION		
PREFERRED	CASTER 4.0°	CAMBER - 0.25°	TOTAL TOE-IN + 0.25°
RANGE	3.55° to 4.45°	+ 0.15° to - 0.70°	0° to + 0.5°
MAX RT/LT DIFFERENCE	0.5°	0.5°	0.5°

REAR AXLE	SPECIFICATION		
PREFERRED	CAMBER -.25°	THRUST ANGLE 0°	TOTAL TOE-IN +.25°
RANGE	0° ± 0.5°	0° ± 0.25°	0° + 0.5°

TORQUE SPECS

FRONT TORQUE SPECIFICATIONS			REAR TORQUE SPECIFICATIONS		
DESCRIPTION	N-m	Ft. Lbs.	DESCRIPTION	N-m	Ft. Lbs.
Clevis Bracket to Lower Control Arm	169	125	Shock Absorber Upper Bolt	95	70
Hub Bearing Knuckle Bolts	136	100	Shock Absorber Lower Bolt	115	85
Lower Ball Joint Nut	95	70	Suspension Arms Lower Axle Bracket Nut	210	155
Lower Control Arm Bolt	142	105	Suspension Arms Lower Frame Bracket Nut	176	130
Lower Control Arm Bolt/Nut Front Pivot	169	125	Suspension Arms Upper Axle Bracket Nut	136	100
Shock Absorber Clevis Bracket	81	60	Suspension Arms Upper Frame Bracket Nut	129	95
Shock Absorber Upper Nuts	95	70	Track Bar to Axle	190	140
Stabilizer Bar Retainer Bolts	142	105	Track Bar to Rear Structure	190	140
Stabilizer Bar Link Upper Nut	135	100	Stabilizer Bar Retainer Bolts	46	34
Stabilizer Bar Link Lower Bolt	115	85	Stabilizer Link Nut to Stabilizer Bar	88	65
Upper Ball Joint Nut	75	55	Stabilizer Link to Body Bolt	102	75
Upper Control Arm Bolt/Nut to Body	122	90	Jounce Bumper Bolt to Body	54	40

Final Notes:

- After installation is complete, double check that all nuts and bolts are tight. Check to ensure there is adequate clearance between all rotating, mobile, and fixed members.
- Ensure there is adequate clearance between exhaust and brakelines, fuel lines, fuel tank, floor board, and wiring harnesses. Check steering gear for interference and proper working order. Inspect brakelines for damages and adequate clearance.
- With the vehicle on the floor, cycle steering lock to lock and inspect steering, suspension, driveline and brakeline systems for proper operation, tightness and adequate clearance.
- Have headlights readjusted to proper settings.
- Have a qualified alignment center check and realign to above specifications.

SEAT BELTS SAVE LIVES. PLEASE WEAR YOUR SEAT BELT.