

4C Retaining Ring & Shim Kit

Part No.

72978-01K

- Retaining Ring .078" Thick
- G-Loc Ring
- Shim

Chrysler 45RFE, 545RFE, 65RFE, 66RFE, 68RFE

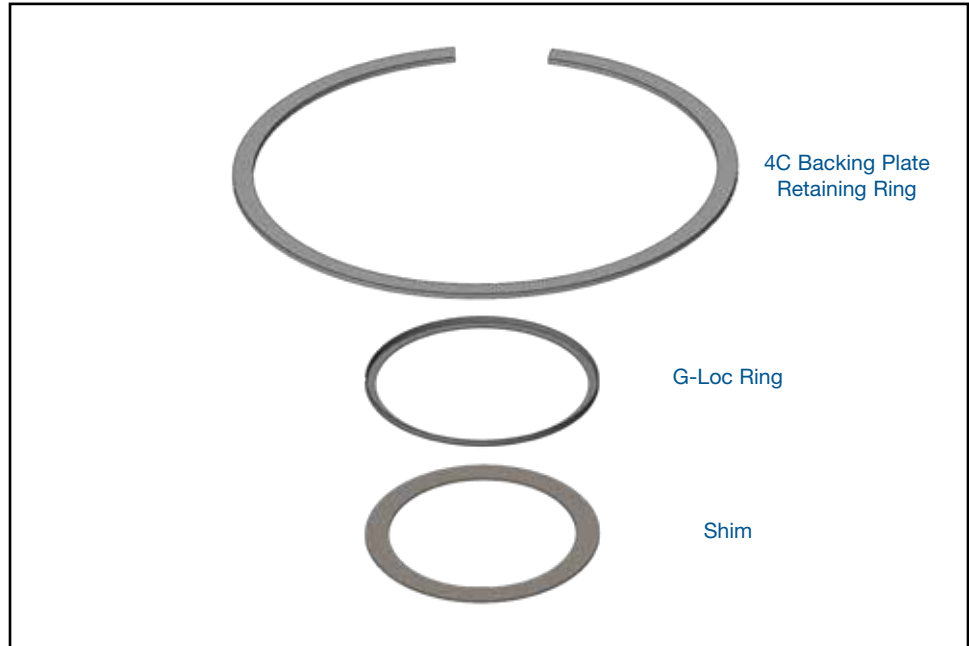

NOTE: The 4C clearance specification is .030-.055". Setting clearance closer to the high end of spec and installing the included spring pack shim preloads the return spring for increased force. The increased return spring force helps slightly tune the 4C clutch to release more quickly, improving 4C to OD shift timing when more aggressive quicker applying OD clutch packs are used (see page 2).

1. G-Loc Retainer & Shim Installation

- Install OE 4C piston and return spring.
- Install Sonnax shim on top of OE return spring (Figure 1)
- Install Sonnax G-Loc retainer on top of shim.
- Compress OE return spring and install OE retaining ring.
- Crimp G-Loc retainer all around circumference (Figure 2, page 2).

2. Backing Plate Retaining Ring Installation

- Assemble 4C clutch and check clearance. Clearance spec is .030-.055".
- Use Sonnax .078" thick backing plate retaining ring if needed to adjust clutch clearance (Figure 3, page 2).

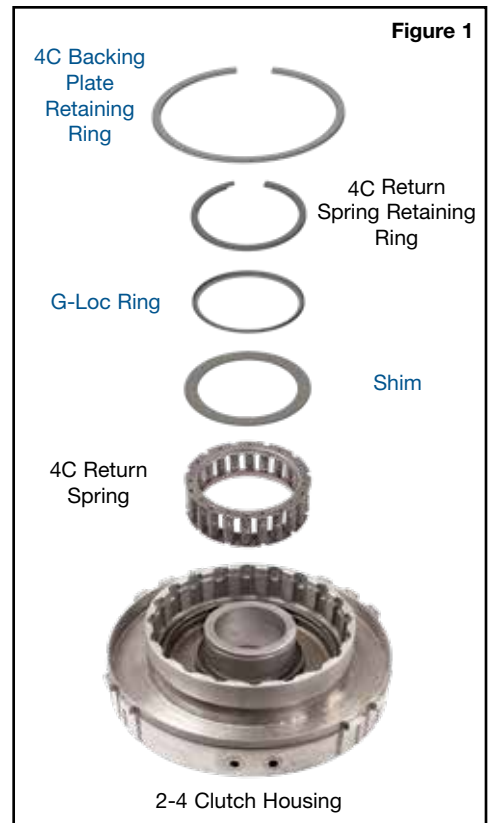

Backing Plate Retaining Rings		Figure 3
OE	.070" (1.79mm)	
Sonnax	.078" (1.98mm)	
OE	.087" (2.20mm)	
OE	.103" (2.61mm)	

