

# 6R80-VBR-NT (No Tools Included)

Parts Only Re-Fill Kit for 6R80-VBR-WT  
(Solenoid & Lube Regulator Repair Kit)

## Prevents-Corrects-Reduces

Persistent Coast-down Clunk Hot, Ratio Codes,  
Long slip-sliding shifts hot. Premature Bushing

Fits: FORD 6R60, 75 & 80 (2006-20)

Also fits: ZF6HP19, 26 & 32 Gen 1 (2003-up)

There are many model  
specific differences!  
Re-assemble your model  
as you found it.



If you need tools order:  
**6R80-VBR-WT**  
Contains reaming tools  
& 1 set of parts.

## I.D. The Valve Body First!

**This Kit Only Fits Vented VB's**

**Large or Small**

Ford 6R60 thru 80 Series  
ZF6HP-19, 26 & 32 Gen 1 Series

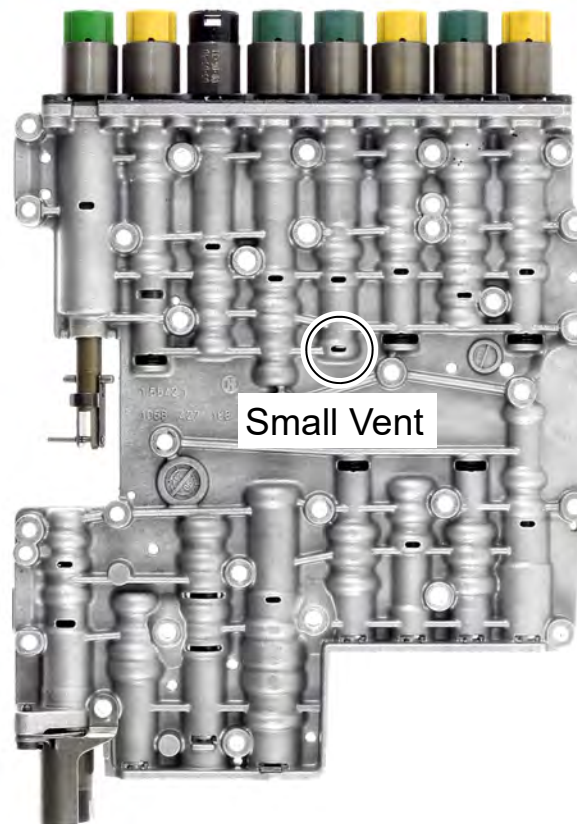
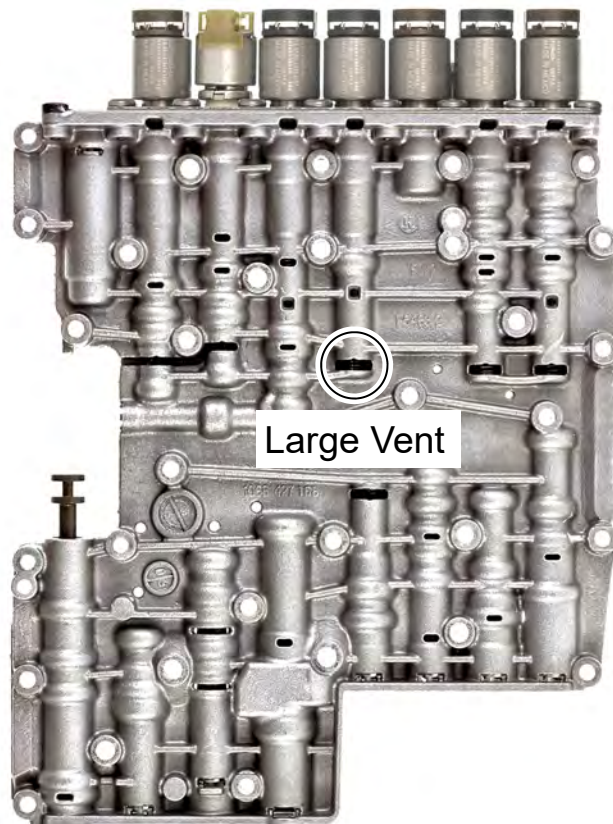

**This kit does NOT fit ZF6HP-21, 28 & 34's**  
(Valve body's without a Vent)

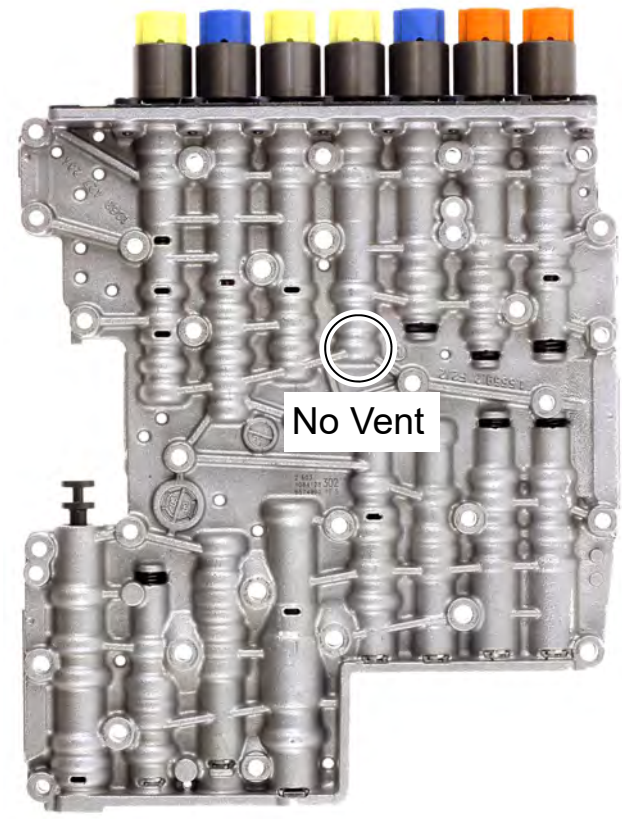

# I.D. The Valve Body First! See Front Page!

## Step 1

Disassemble VB and note ALL small part locations. Check your separator plate. New separator plates are available from distributors, some "printed" plates are replaced by bonded gasket plates. Plates are cheap insurance against cross-leak malfunctions.

**Helpful Information**

**Resetting Adapts:**  
Do yourself and this car a BIG favor. Warm the trans temp up to about 140 degrees and use a good scan tool to "reset" the adaptive learned values.

**Solenoid Usage:**  
Always replace *discolored* or *overheated* Solenoids! See Solenoid Information Sheet for details.

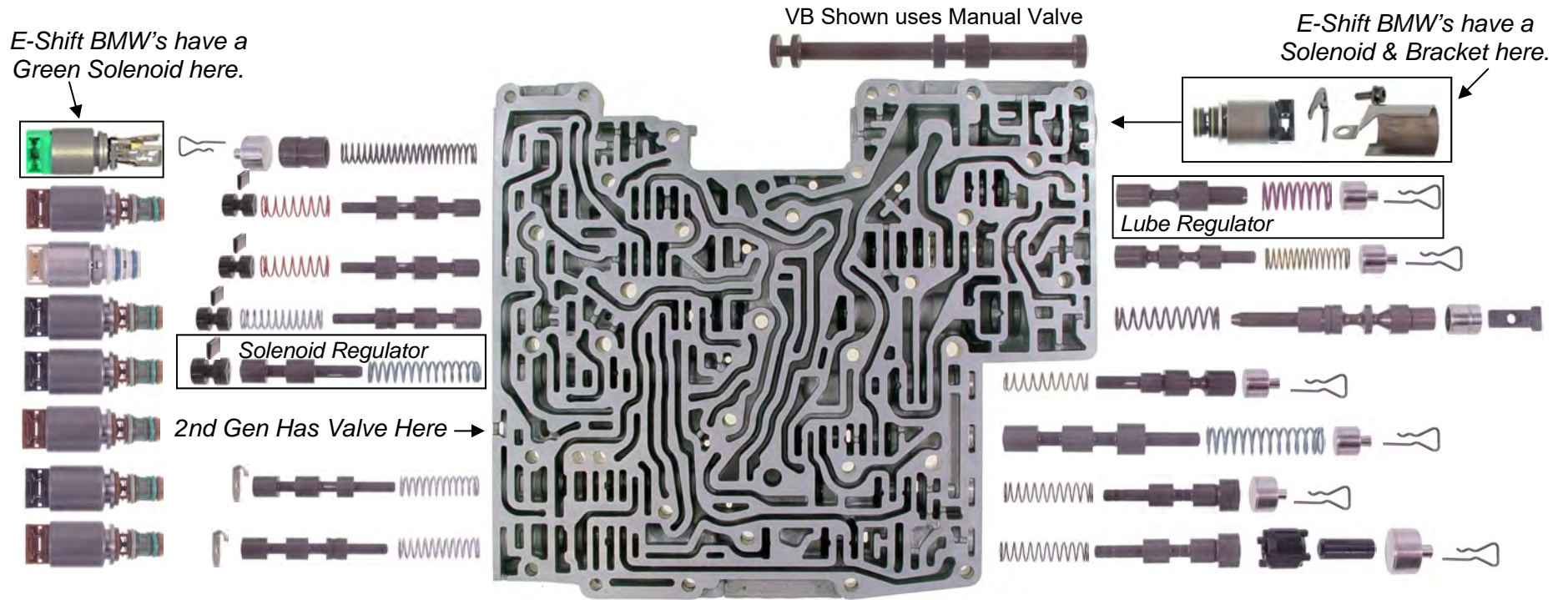

**Heads up!** Some valves may or may not have springs! Depends on model.  
Always re-assemble valves and small parts as you found them!



# Solenoid Regulator Repair

**Step 1.** Remove **Solenoid Regulator** from VB. Discard original valve and spring. Keep end plug and retainer.



**VB Type ID**  
**Look for Vent Here!**  
 Must have a Vent, Large or Small.  
**This kit only fits Vented VB's!**

**Reaming Tip:** The less you push, the slower you go, the better the finish!  
 Reamer will stop when **it contacts** the Solenoid Reg. Spacer.

**The Spacer Stops the Reamer!**  
 Never Ream **Solenoid Reg. bore** without using spacer or severe damage will occur!

**Step 2.** Flooding bore with WD-40 while reaming works best. Slide shank end through largest hole of Solenoid Reg. Reamer Guide. **Insert Solenoid Reg Reaming Spacer into the bottom of the empty Solenoid Reg. bore NOW.**

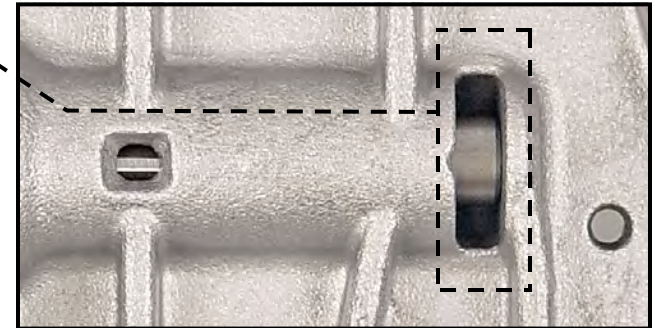

**Step 3.** Insert guide bushing and reamer into bore until Reamer **Guide** bottoms out. Use locking pliers **just snug** on the guide to keep it from spinning. Turn reamer at slow speed with drill until reamer contacts the **Solenoid Reg Reaming Spacer**. Remove Guide, Reamer and the Reaming Spacer & save them. Rinse & Clean out chips.

**Step 4.** Check New Solenoid Regulator Valve in bore for free movement. Then clean & lube **New Solenoid Reg Valve** & install as shown with new **Blue** spring. Then re-install original end plug and retainer.

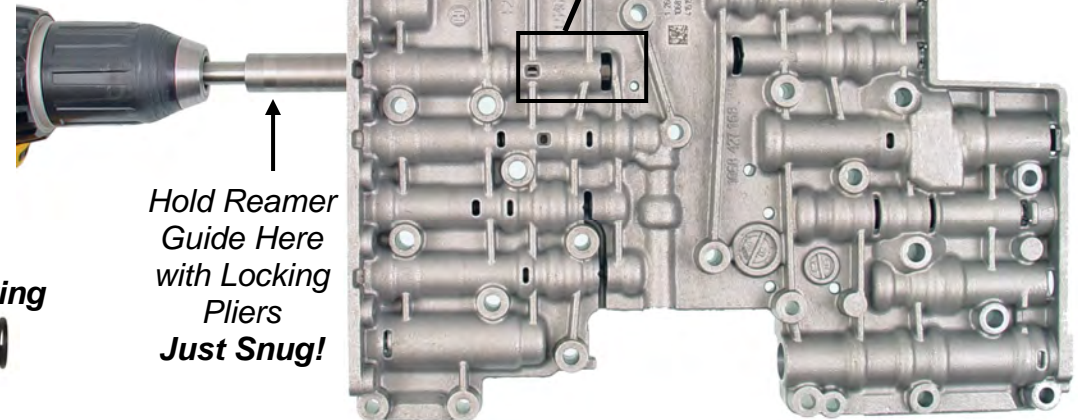
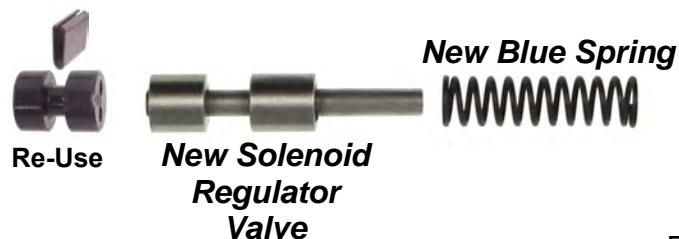

# Lube Regulator Repair

**Step 1.** Remove **Lube Regulator** from VB.  
Discard original valve and spring. Keep end plug and retainer.

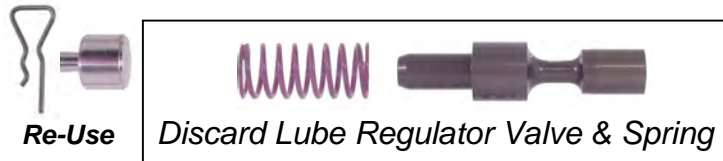

**Step 2.**  
Flooding bore with WD-40 while reaming works best. Slide shank end through largest hole of Lube Reg. Reamer Guide.



**Step 3.** Insert guide bushing and reamer into bore until Reamer Guide bottoms out. Use locking pliers **just snug** on the guide to keep it from spinning. Turn reamer at slow speed with drill. You're finished when the **tip of the reamer contacts the inner wall** as shown. Turn valve body over, rinse and blow out chips. Do final cleaning on entire VB.

**Step 4.** Check New Lube Reg. Valve in bore for free movement, then clean & lube **New Lube Reg Valve &** install as shown with new **Large Diameter/Short Orange Spring** then re-install original end plug and retainer.



***The Solenoid Regulator Reaming Spacer is NOT USED for reaming the LUBE Regulator Bore!***

Reamer tip contacting inner wall.

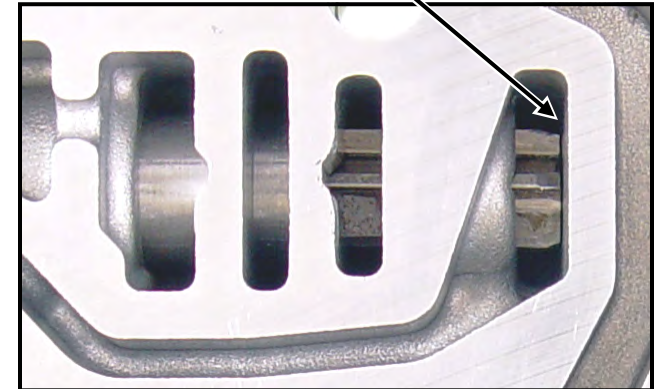

Hold Reamer Guide Here with Locking Pliers Just Snug!

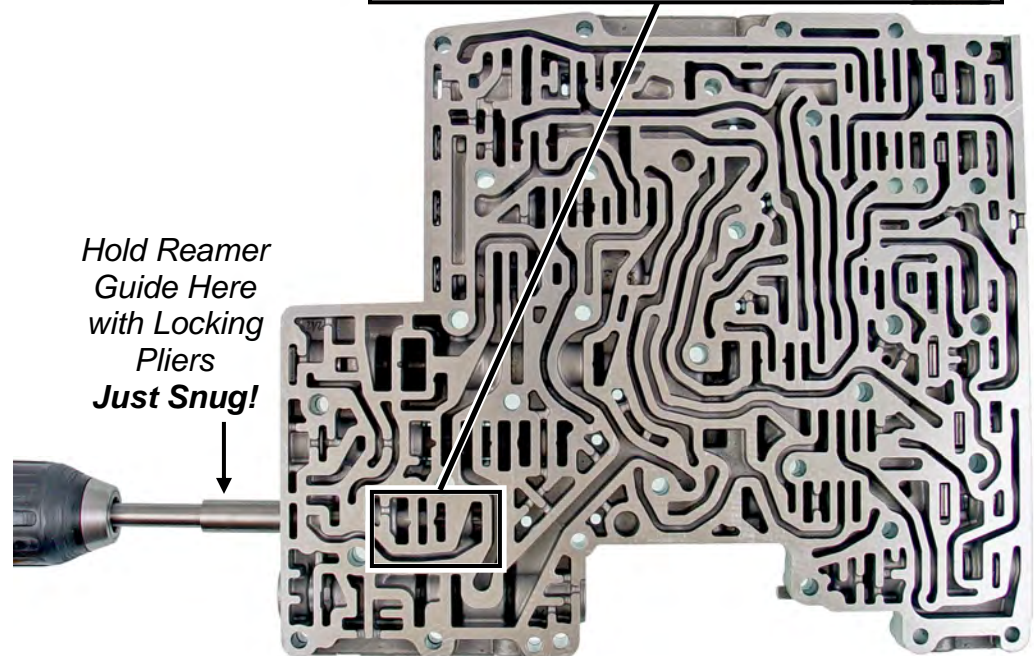



# Additional Information for Ford Models

Re-install ALL small parts to their original locations!

If the **Separator** plate has a hole OVER a dampener location, a dampener MUST be installed IN that location. **Later models only use 2 dampeners.**

Watch for damaged/crushed pulse dampeners.



Parts & locations differ by model. Re-install ALL small parts to their original locations!

This Model Used:

⊙ = 8 Check Balls

■ = 6 Dampeners

**Watch for damaged plate printing!**  
Splitting the VB halves usually pulls the printing off somewhere on the plate. Plates are available from your supplier.

**6 Dampener Plate P/N: CL3Z-7Z-490-C**  
**2 Dampener Plate P/N: CL3Z-7Z-490-D**  
Replace with same type plate.

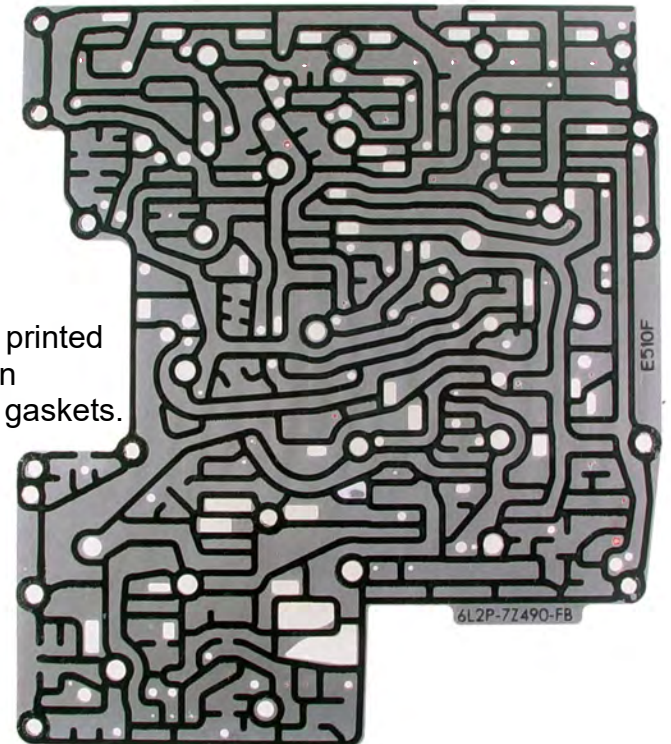
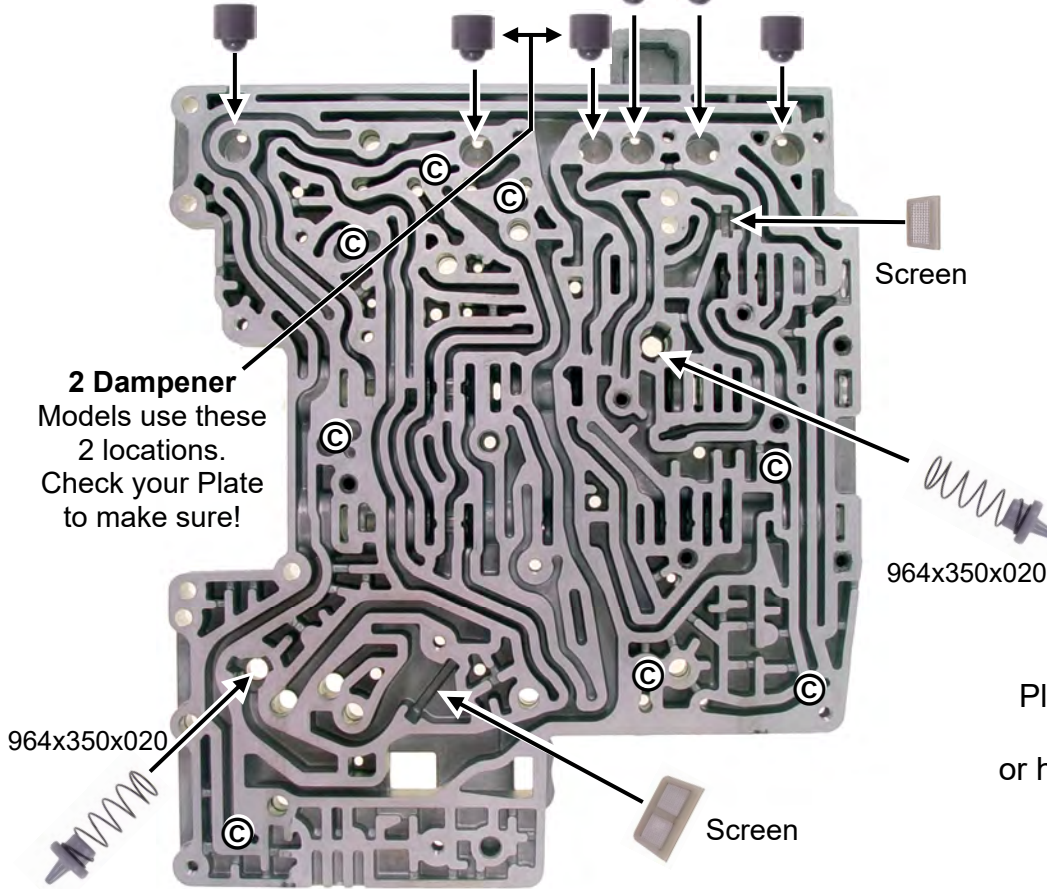

Plates may be printed as shown or have bonded gaskets.

**Fluid level** must be at top of hash marks with trans temp @ 190F degrees to purge air from cooler circuits! Use scan tool to determine fluid temp. Don't let it out the door with a low fluid level! Do not overfill either!



# ZF Additional Information

## Typical M-Shift Valve Body Layout

Mark locations of ALL small parts and re-install as you found them. They are model specific.

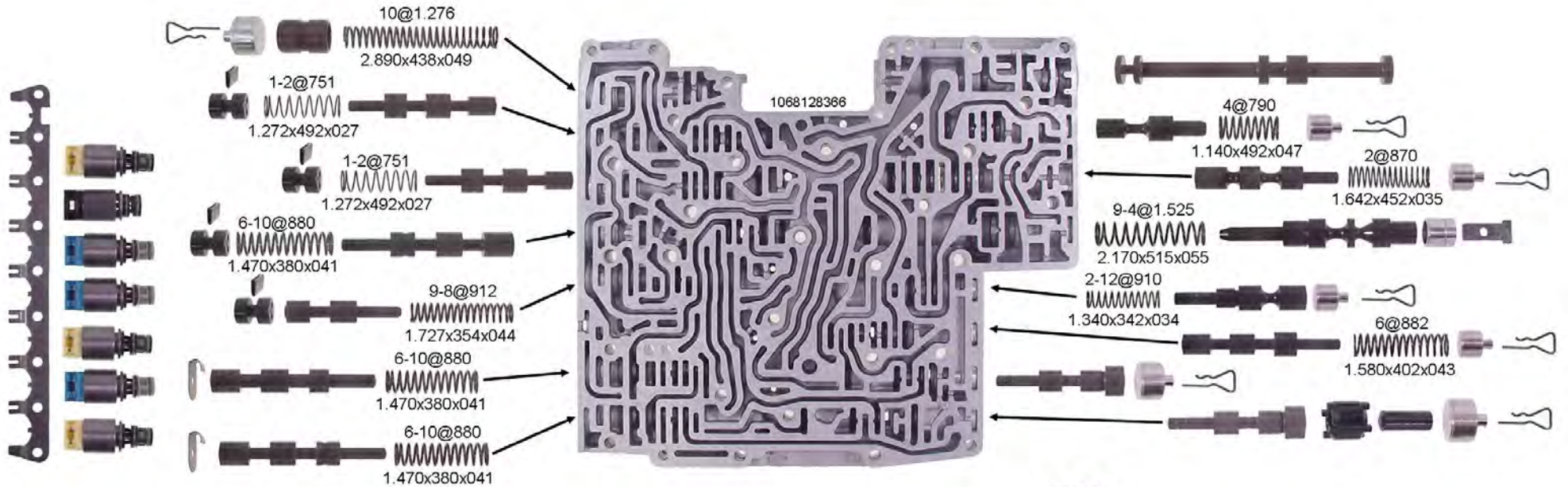

### Plate ID Number Location

Distributors may need your plate ID number when ordering a new one.

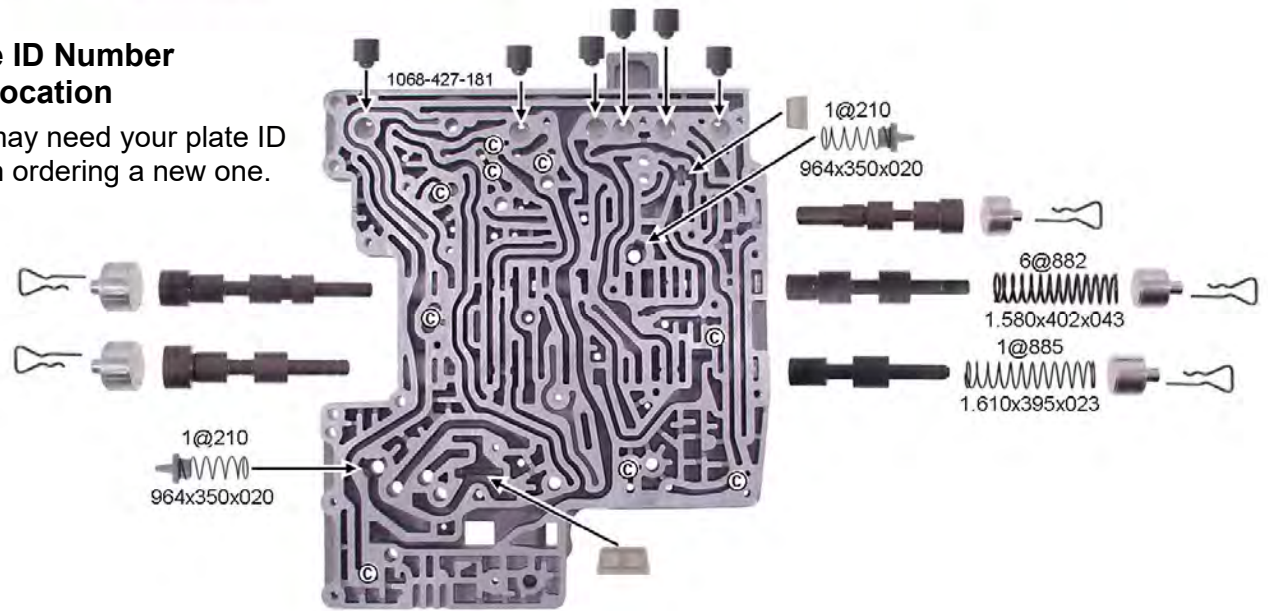
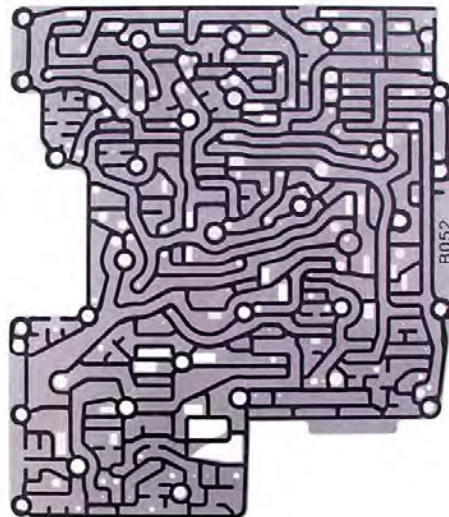



# ZF Additional Information

## Typical E-Shift Valve Body Layout

Mark locations of ALL small parts and re-install as you found them. They are model specific.

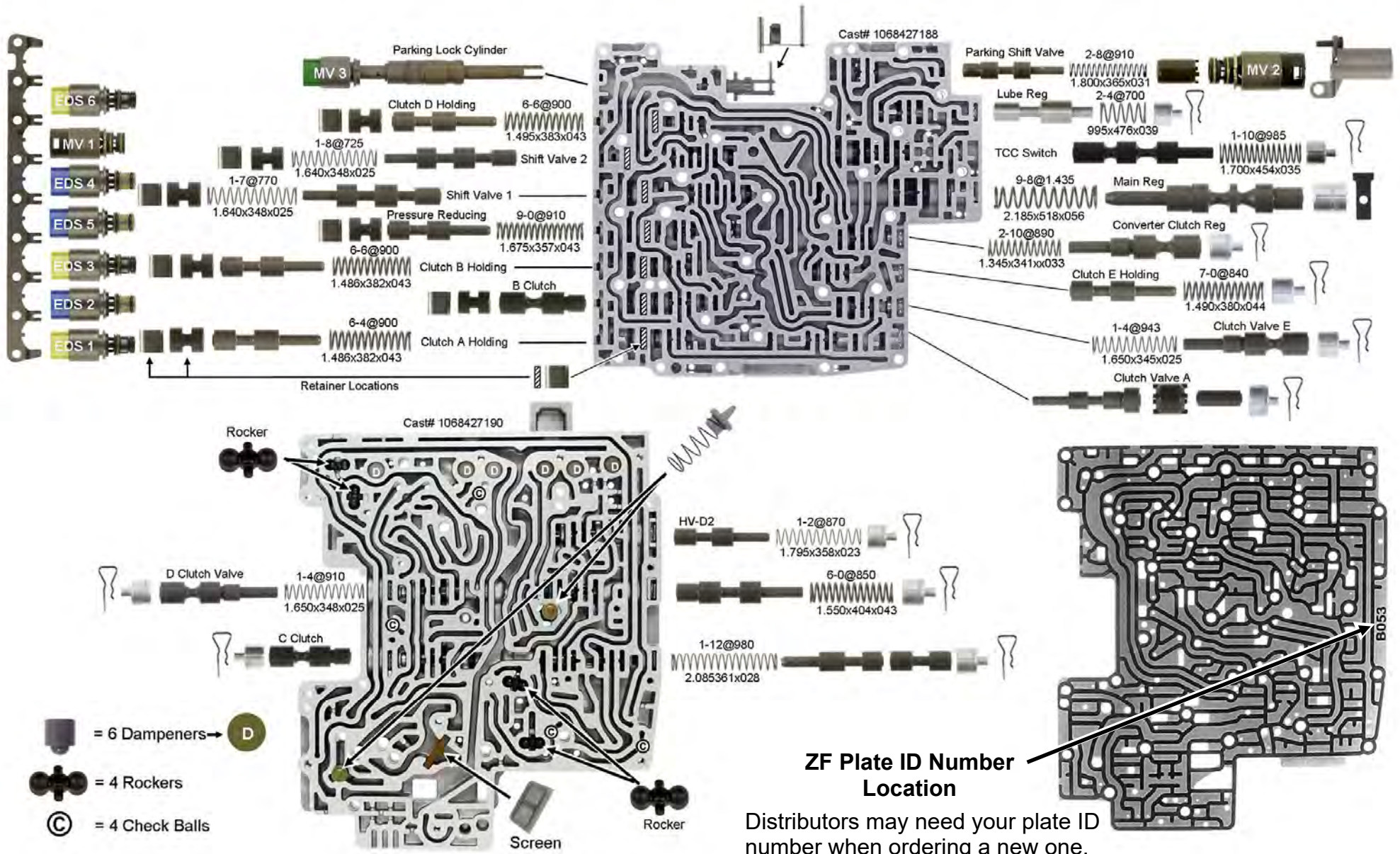



# Important ZF Solenoid Information (Imports)

These two sets of solenoids are supposed to be the same colors. The left set has **overheated** and should **not** be used. **Overheating** is what **caused** the **color change**. Even though the bottom left solenoid connector might “Look” Green, it was originally **Blue**. The top left may appear cream or burnt orange in color but it too was over-heated, the original color was actually **Yellow**. If your Solenoids turned color **REPLACE THEM!** Do not ask them to go another 100k, **they won't!**

**Overheated**

**Normal**

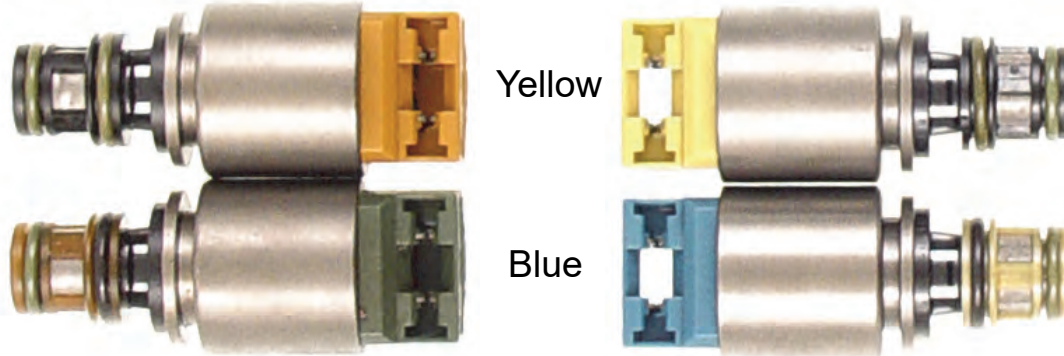

Yellow

Blue



Orange— Common on Late Audi.  
Don't mistake for Over-heated Yellow!

The actual quantity of blue or yellow solenoids depends on the manufacturer.

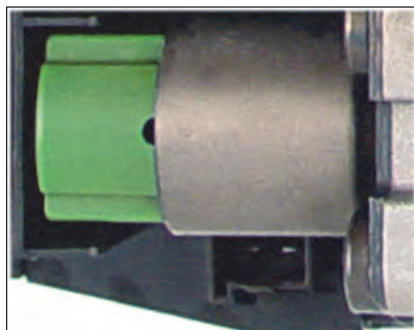
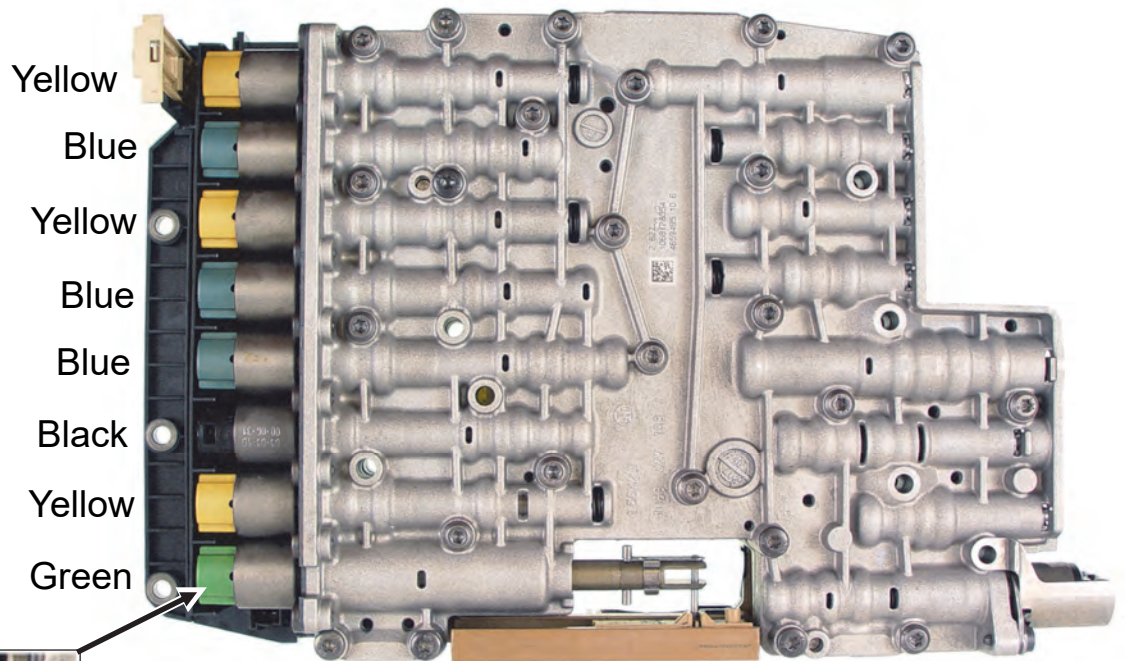

Green MV3 Solenoid is used in models without a shift cable.  
(BMW Typically)

**Only this Solenoid is Green!**

MV2 & MV3 are only on models without a shift cable.

MV2 Black



# Additional Information

Ford uses a combination of Black, Brown and Cream colored Solenoids. While the discoloration is harder to see on black and brown solenoids when they overheat, you can see enough difference when comparing the browns. Let that be your guide when deciding to put a set of solenoids on.

## A Note about Resetting Adapts:

Do yourself and this car a **BIG** favor. After filling, warm the trans temp up and use a scan tool to “reset” the adaptive learned values where applicable. This can save hours of driving time trying to get one to relearn.

**Audi:** Resetting Adapts may be called **EE Prom Reset** and may not be available on all scan tools.

Extended road testing alone will not relearn the vehicle enough to deliver. EE Prom Reset is the only method to successfully reset the vehicle adapts found at this time.

## Internal Connector:

Late model Fords without TCM in the trans are known for speed sensor failures. A TSB was issued for the concern. Replace the Lead Frame Connector.

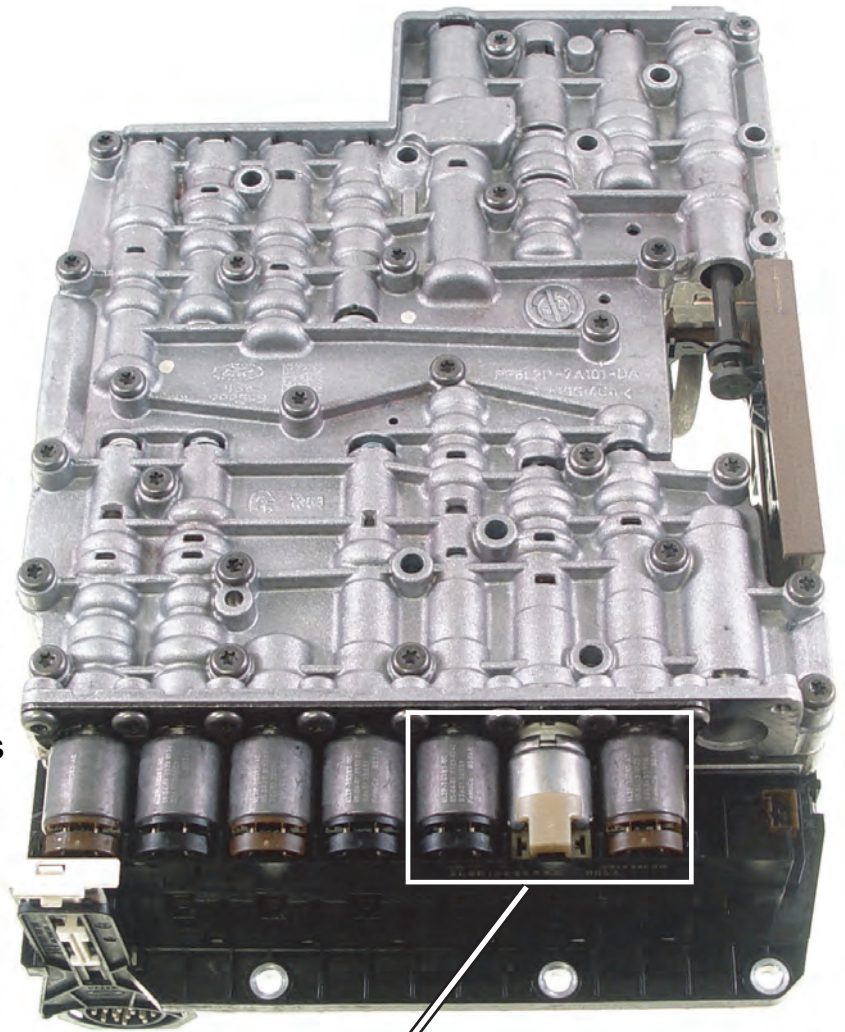

Black

Cream

Brown