

SK[®] 4

1964 C-4 (Also Early 1965 Mustang)

Reduces/Corrects/Prevents:

Soft 1-2 Shift, Passing Gear Spin-up, Clutch Chatter and Soft 2-3 shift.



STOP! LOOK HERE FIRST!

Step 1

Discard original springs and install **NEW Blue** Spring on D2 Shift and **NEW Red** on 2-3 Shift valves.

If you have a Large spring on the 2-3 shift valve, discard it. Only use New Red Spring provided.

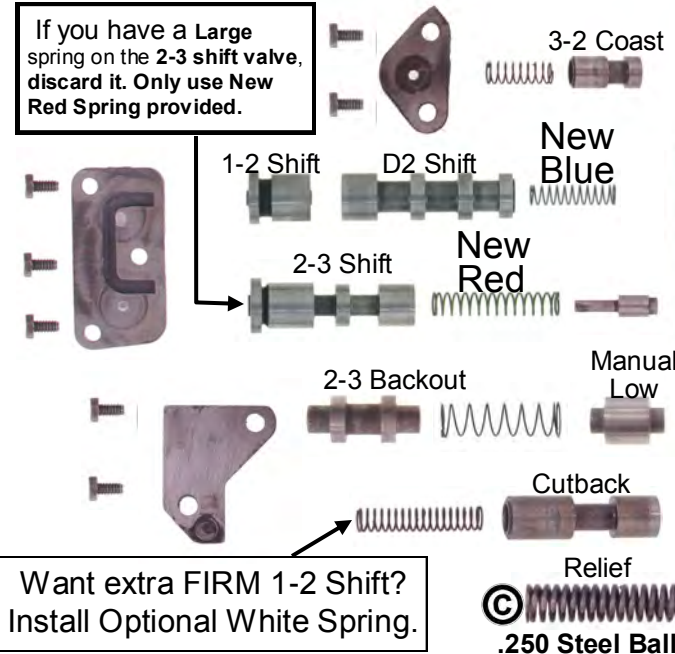

Want extra FIRM 1-2 Shift? Install Optional White Spring.

Tech Note: Carefully grind a slight chamfer all the way around on the modulator valve as shown. This reduces the chance of valve stick.
2 outer edges only!

C4-64

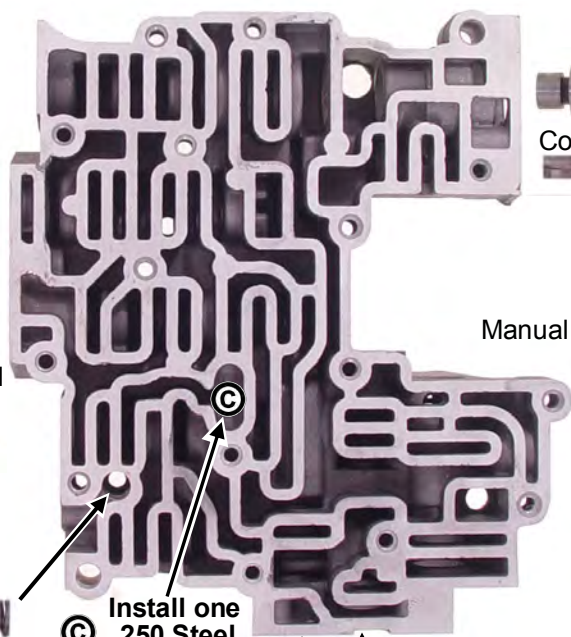

Step 2

Discard original spring and install

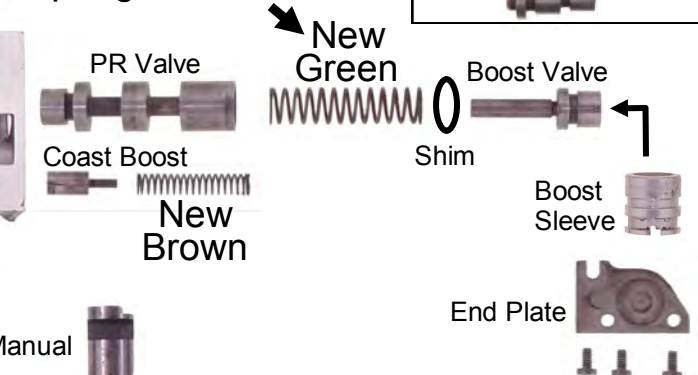

Use SK[®]4L Kit if your VB has this style Boost valve.

Step 3

Discard original spring and install **New Brown** spring on Coast Boost.

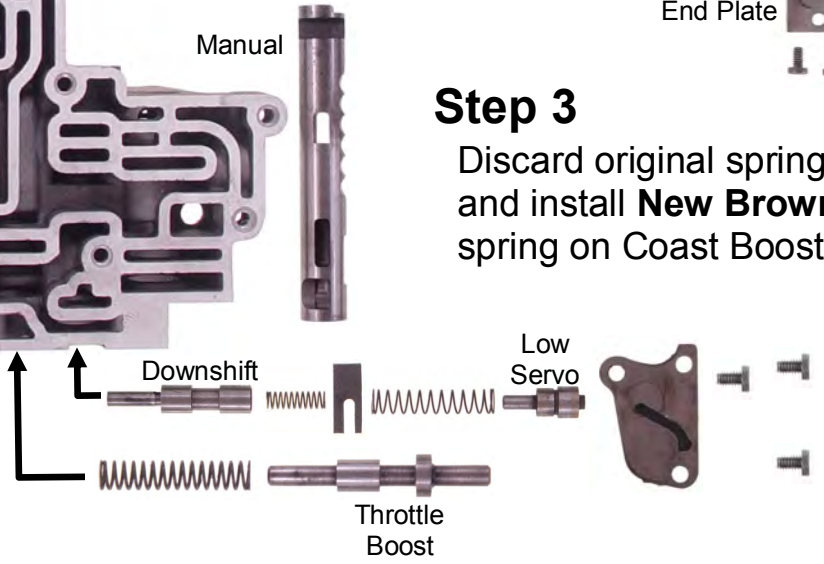

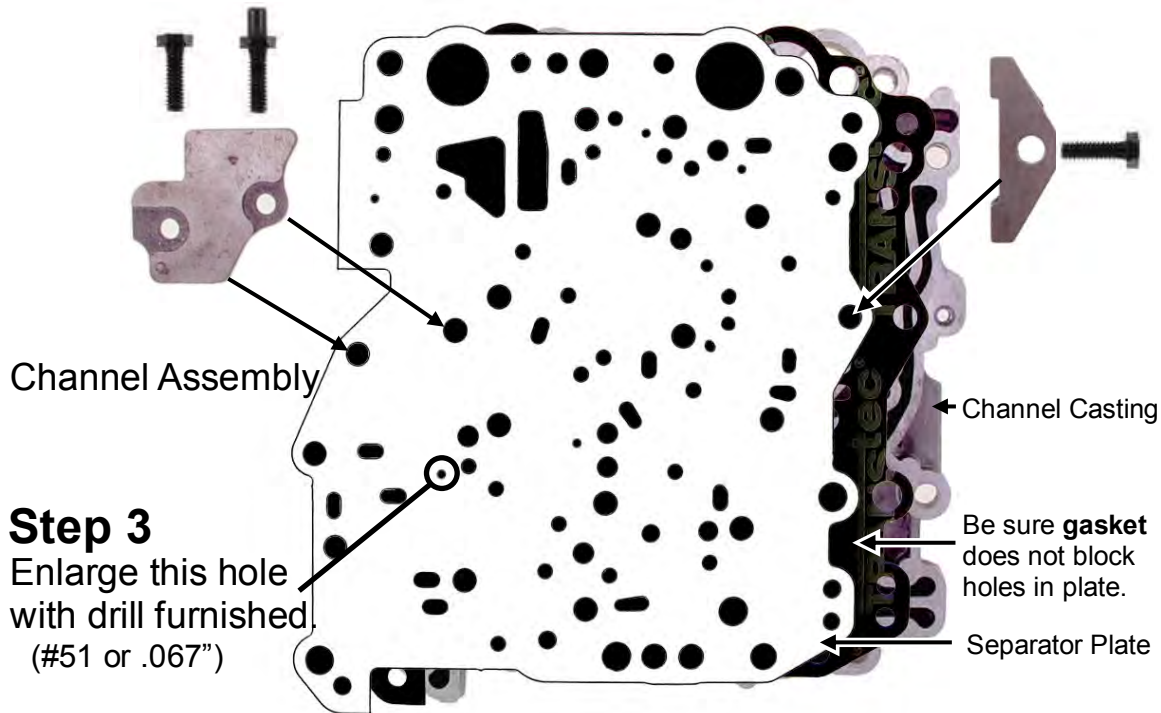

Step 3
Enlarge this hole with drill furnished (#51 or .067")

64-66 models **do not** use any check balls in Channel Casting.

Step 4

Revised Band Adjustments:

Front Band: Tighten 10-12 inch pounds (snug with short wrench) and back off exactly 1½ turns.

Rear Band: Tighten 10-12 inch pounds (snug with short wrench) and back off exactly 1½ to 2 turns.

Step 5

Vacuum Modulator:

Use only WHITE STRIPE adjustable type.

Adjusting Modulator:

Early shifts feel better and also give your customer better economy and overall performance. Turn adjusting screw counter-clockwise makes earlier shifts.

Step 6 If trans is apart or during overhaul:

A.) Drum Surface where front band rides: If scored, replace drum. If smooth, sand drum with 100-120 grit paper going around the drum. (Same direction as it rotates) Do not sand front to back.

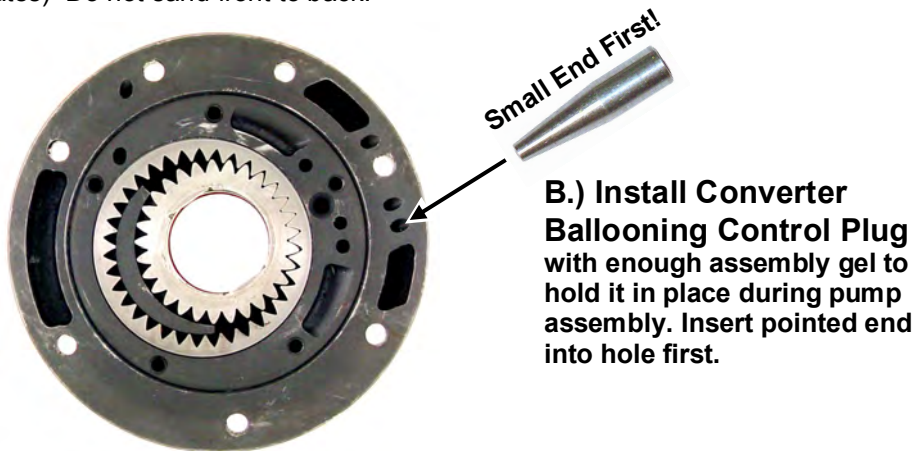

B.) Install Converter Ballooning Control Plug with enough assembly gel to hold it in place during pump assembly. Insert pointed end into hole first.

Additional Information

Valve Body. The valve body is the heart and mind of the transmission. In order for the transmission to perform crisply and with reliability, it must receive strong precise signals from the valve body. Poor valve body action is the primary cause of poor performance and friction failure. There are two main causes of improper valve functioning. They are: (A) Calibration and (B) Sticking or dragging valves.

- A. Calibration. As the engine and transmission wear, conditions change requiring recalibration of the valve body to maintain or restore crisp performance and reliability. A Shift Kit® furnishes this recalibration.
- B. Sticking or dragging valves. This valve body has a very low tolerance to debris and metal particles which scratch the valve bores causing valves to stick. Don't even think about using the converter over. It's a primary source of metal particles that can later make your life miserable when the particles reach the valve body.
- C. Don't over tighten the small valve body screws. 24-28 inch pounds.