

[Return to Instruction Sheet index](#)

Installation Instructions for

TCI[®] 378805 Turbo 700R4 1982-1984

TCI[®] 378905 Turbo 700R4 1985-1993

KIT INTRODUCTION

Read all instructions first to familiarize yourself with the parts and procedures. Work slowly and do not force any parts. Burrs and dirt are the number one enemies of an automatic transmission. Cleanliness is very important so a clean work area or bench is necessary. We suggest a clean work bench to from which oil can easily be cleaned or a large piece of cardboard.

REBUILD GUIDELINES

For a successful rebuild TCI[®] recommends following these guidelines as you install your Truckmaster kit.

- If you are not familiar with the 700R4 it is a good idea to purchase a rebuild manual such as TCI[®] part number 893000 (1982-1986) or 893001 (1987-1993). TCI[®] also carries a video (898000) that provides valuable insight on the fundamentals of inspection and modifications of automatic transmissions.

- Inspect the front pump castings, rotor and slide for excess wear.

- Thoroughly check your case for cracks and stripped threads before rebuilding the unit. Also, inspect the center support lugs inside the case for excess wear.

- Look closely at the bores machined in the case (i.e. accumulator, intermediate servo, and governor). Worn governor bores can be repaired at local transmission shops.

- TCI[®] 374301 0.500 in. diameter boost valve will aid in increasing torque capacity and durability.

- The 700R4 band is used for 2nd and 4th gear. Band life may be extended by installing a Corvette servo assembly TCI[®] 376003.

- Check the lands on the governor shaft for scoring and wear. Minimum O.D. that is acceptable is 0.798 . Be sure that the governor valve is not sticking.

- Build the clutch packs to the following clearances:

Lo/Reverse: 0.060 - 0.080 in.

Forward: 0.015 - 0.030 in.

Band 0.062 - 0.100 in.

3-4: 0.050 - 0.065 in.

Unit endplay: 0.005 - 0.015 in.

DRAIN PLUG INSTALLATION

STEP 1 If your transmission pan does not already contain a drain plug then thoroughly clean it and make sure it is still usable. Select a good location for the drain plug. We recommend that you install the drain plug in a location that will provide easy access and allow the fluid to drain completely.

STEP 2 After you have marked the location, drill a hole using a 29/ 64" (.453) bit. Take a round file and deburr the edges of the opening. Next, clean the transmission pan.

STEP 3 Screw the insert into the pan. The plastic sealing washer fits against the outside of the pan. Using the 3/4 nut, secure the insert. (Nut screws onto insert from inside the pan.)

STEP 4 Insert the 1/16" pipe plug into the insert and tighten.

VALVE BODY MODIFICATIONS

STEP 1 M.T.V. Up Valve: (**See Figure 1**) Remove the roll pin holding the M.T.V. Up Valve assembly. Remove aluminum plug, valve and spring. Discard spring. Reinstall the valve, aluminum plug and roll pin. The roll pin must fit flush with the casting.

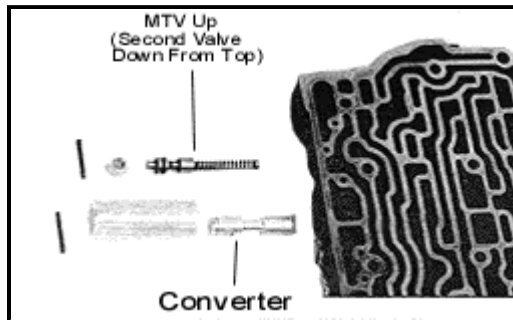

Figure 1

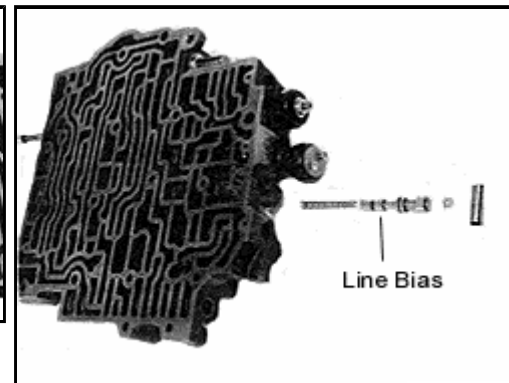
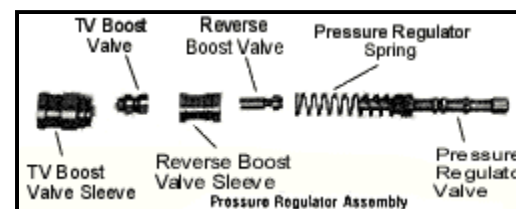

Figure 2

STEP 2 Converter Clutch Valve: (**See Figure 1**) DIESEL APPLICATION: DO NOT MODIFY. Skip to Step 3.

NOTE: Some 1984-1/2 and later models do not use this valve assembly. They will have aluminum plugs installed in this position. No modifications are necessary. **NOTE:** Do not install black spring on converter clutch valve on the valve body. You can actually see the valve assembly in the bore. If you do not see a spring, no modifications are necessary. If you can see a spring then you must do the following modification. Use a small punch to push the roll pin out. Carefully remove the converter clutch throttle valve and sleeve assembly. Do not remove the converter clutch valve from the bore. Remove the throttle valve and spring from the sleeve. Replace the stock spring with the **Black** Spring supplied. Install throttle valve and new spring into the sleeve. Install sleeve assembly into valve body. Replace roll pin. Tap it into place. Make sure the roll pin is completely inside. It should be flush with the casting.

STEP 3 Line Bias Valve: (**See Figure 2**) Remove the large roll pin holding the line bias valve assembly. Be careful not to damage this pin. Remove the aluminum plug, valve and spring. Replace the stock spring with the **Green** Spring supplied. Install new spring, valve and aluminum plug into the valve body. Reinstall roll pin being sure it fits completely into the bore. The roll pin should be flush with the casting.



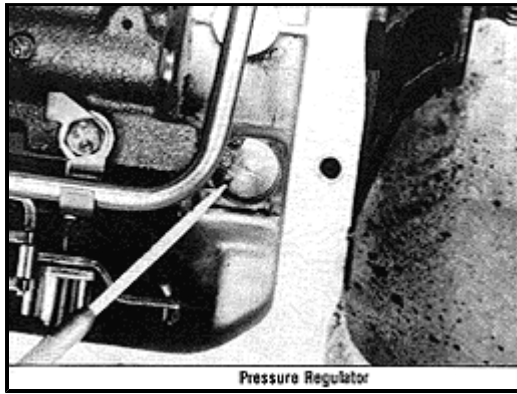

Figure 3

Pressure Regulator Modifications (See Figure 3)

STEP 4 All Applications: Remove the pressure regulator assembly from the transmission pump. Push down on the TV boost valve sleeve while removing the retaining ring. Be careful as there is heavy spring tension behind it. Slowly lower the sleeve to relieve spring tension. Remove the TV boost valve sleeve and valve, the reverse boost sleeve and valve, and the pressure regulator spring. The pressure regulator valve may also drop out. If it does not, do not remove. Replace the pressure regulator spring with the Purple Spring supplied. Reinstall the pressure regulator assembly with the new spring as shown. (**See Figure 4**) install the new retaining ring supplied with this kit. **NOTE:** The boost valves and reverse boost sleeve can easily be installed incorrectly. Incorrect assembly will cause the transmission to function improperly. BE SURE these parts are installed in the correct order, facing the right direction.

STEP 5 3-4 ACCUMULATOR ASSEMBLY: (**See Figure 5**) Install the thick spacer supplied (silver) into the accumulator piston with some grease to hold it into place. Install the 3-4 piston pin into the case. Install the accumulator piston/spacer assembly into the case. Install the stock spring against the spacer.

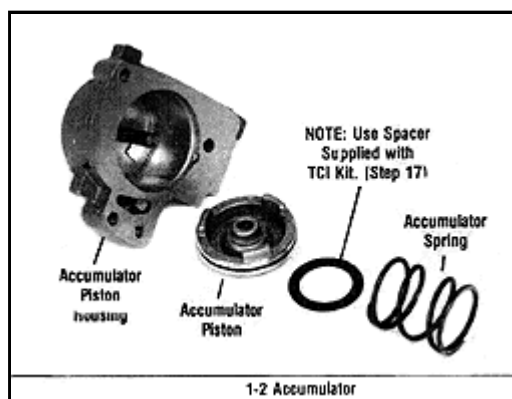

Figure 5

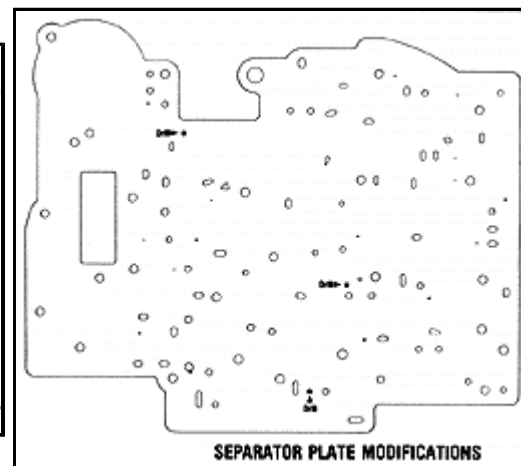

Figure 6

STEP 6 SEPARATOR PLATE: **All applications:** (**See Figure 6**) Using 1/8" drill bit supplied with kit, enlarge the three (3) holes indicated on **Figure 6**. Deburr and clean before reinstalling plate.

STEP 7 CHECK BALL LOCATIONS: **All applications:** VALVE BODY: Install check balls in the valve body as indicated (**See Figure 7**) CASE: Install three (3) check balls in the case as shown (**See Figure 8**). Use grease to hold check balls in place. 1988 AND LATER: Install two (2) check balls in the case as shown (**See Figure 8**). Use grease to hold check balls in place.

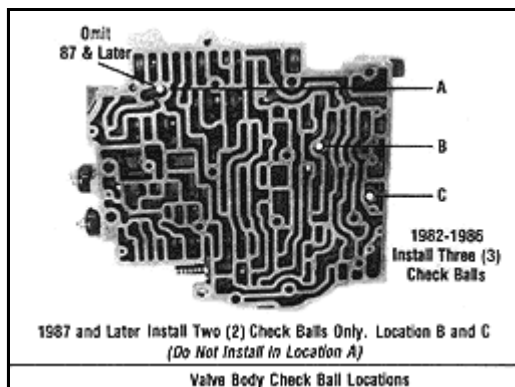

Figure 7

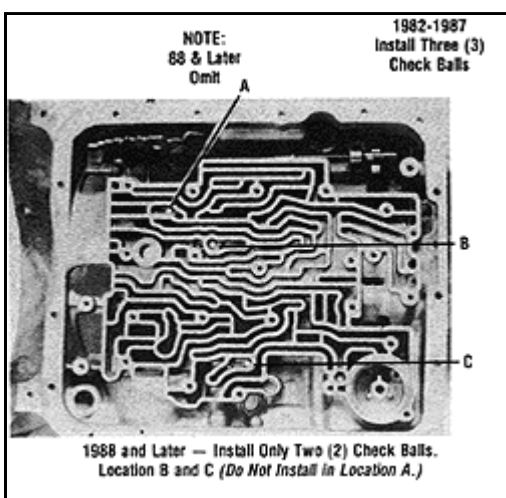

Figure 8

STEP 8 Place the separator plate with gasket against the transmission case. Install the small support plate (1982-1986) or auxiliary valve body plate (1987 and later). Install check ball (**See Figure 9**) and four (4) OEM bolts loosely. Insert two (2) valve body bolts into the two (2) alignment holes in the separator plate. Tighten the support plate bolts. Remove two (2) valve body bolts from the alignment holes.

STEP 9 **INSTALL VALVE BODY:** Be sure to engage manual valve with linkage properly. Do not force the valve or bend the linkage during assembly. Install one (1) valve body bolt to hold the valve body into place. **DO NOT TIGHTEN BOLT**

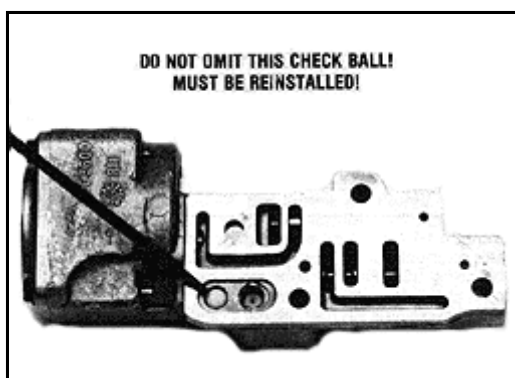

Figure 9

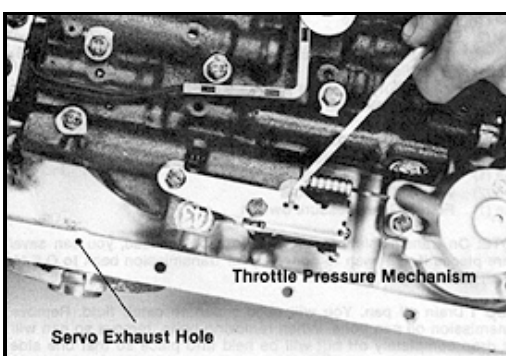

Figure 10

STEP 10 Install the throttle pressure mechanism. Attach the cable linkage to the larger lever. Holding the large lever down and the small lever up, slip the mechanism over the roll pin on the valve body and install the two (2) bolts (**See Figure 10**).

STEP 11 1-2 **ACCUMULATOR ASSEMBLY:** Install the thin spacer (black) into the accumulator piston. Install the piston into the housing. Install the large orange spring supplied with this kit. Now you are ready to reinstall accumulator housing. Install using the housing bolts that were kept separated. Tighten bolts to 8 foot pounds. **NOTE:** If your transmission came with an accumulator separator plate, reinstall.

STEP 12 Install the remaining valve body bolts, the detent roller spring and wire clips. Refer to your wiring diagram. Insert the plug end of the wiring harness into the connector in the case. Install the wire connector onto their proper switches. Tighten the valve body bolts, throttle pressure mechanism bolts and small support plate bolts to 8 foot pounds. Tighten detent roller spring bolt to 10 foot pounds. **DO NOT OVER TIGHTEN.**

STEP 13 Clean all old gasket material from oil pan and the case. Wash pan in solvent and install with new pan gasket supplied. Do not use any gasket sealer. Make sure the servo exhaust hole is not plugged or stopped up (See Figure 10). When cleaning gasket material, some can accidentally get into this opening. Install pan bolt and tighten to 10 foot pounds.

STEP 14 THROTTLE CABLE ADJUSTMENT: Hold gas pedal to the floor and check to be sure the throttle is fully wide open to wide open throttle position.

ADJUSTMENT OF THROTTLE VALVE CABLE IN A GASOLINE ENGINE: Failure to adjust properly can cause damage to your new transmission. **DO NOT DRIVE UNTIL ADJUSTMENT IS CORRECT**

STEP 15 Adjustment is made with engine *NOT* running.

STEP 16 Disconnect the Throttle Valve Cable at the Carburetor so the cable can be moved. Remove the plastic plug from the throttle valve opening in the transmission, you should be able to see a hook in the opening. With needle nose pliers pull the TV link hook out about half an inch. Next, take the end of the TV cable and hook the TV linkage hook into the hole at the end of the cable. Now pull the cable at the other end, making sure that the linkage hook and cable hook fits under the throttle cable housing. Now push the end of the cable housing into the throttle valve cable opening and install the cable (**See Figure 11**).

STEP 17 Now reconnect the TV cable to the carburetor or injection lever.

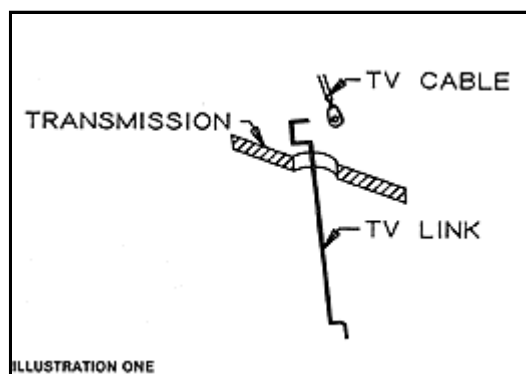

Figure 11

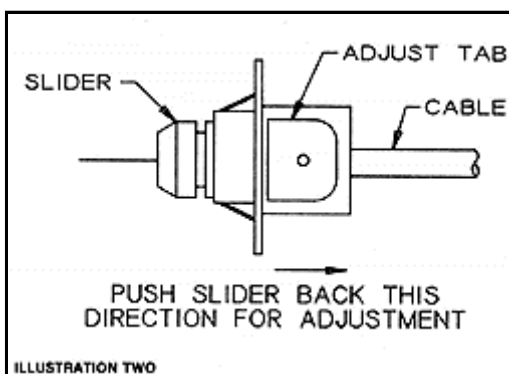

Figure 12

STEP 18 Locate the readjust tab (**See Figure 12**). Depress tab and move slider through the fitting away for the lever assembly. When the slider stops against the fitting, release the readjust tab.

STEP 19 Using accelerator pedal, open the throttle lever to full or wide open throttle stop position. This will automatically adjust cable. Release the throttle lever and check the cable to see that it is not binding or sticking.

STEP 20 Now that the adjustment is complete, road test. With moderate acceleration your transmission should shift:

1 st to 2 nd	15-20 MPH
2 nd to 3 rd	25-30 MPH
3 rd to 4 th	40-45 MPH

If the throttle valve cable is not adjusted properly, the transmission will shift into 1st, 2nd and 3rd within seconds of acceleration. **DO NOT CONTINUE TO DRIVE VEHICLE IF THIS HAPPENS.** Readjust cable. If you continue to

have problems, please contact TCI's tech department for assistance.

STEP 27 Pour five (5) quarts of automatic transmission fluid into the transmission. Start engine and check transmission fluid level. Add additional fluid until fluid reaches full level. ***DO NOT OVERFILL TRANSMISSION.***

03/2000

[Back to Top](#)