

## HOW IT WORKS

THE UNIQUE MICROSTEER TUNING BOX ALLOWS YOU TO ADJUST THE AMOUNT OF ASSISTANCE BY USING A ROTARY POTENTIOMETER OR, IF YOU PREFER, YOU CAN MAKE THE SYSTEM SPEED SENSITIVE BY CONNECTING A WHEEL SPEED SIGNAL TO THE TUNING BOX. A MODE SELECTION SWITCH ON THE BOX ALLOWS YOU TO CHOOSE YOUR PREFERRED METHOD, MANUAL OR WHEEL SPEED.

**PLEASE REVIEW THE IMPORTANT INFORMATION ON PAGE 5 BEFORE ATTEMPTING INSTALLATION**

## MECHANICAL INSTALLATION

INSTALLATION IS EASY - THE MGU IS DESIGNED TO BE FITTED IN LINE WITH THE EXISTING STEERING COLUMN BY REMOVING A SECTION OF COLUMN AND INSERTING THE MGU IN ITS PLACE.

THE MGU CAN BE MOUNTED VIA THE FRONT OR REAR 3xM8 MOUNTING HOLES. YOU NEED A SUITABLE BRACKET TO MOUNT THE MGU AT A MOTOR ORIENTATION THAT BEST SUITS YOUR APPLICATION.

**PLEASE REVIEW THE IMPORTANT INFORMATION ON PAGE 5 BEFORE ATTEMPTING INSTALLATION**

## ELECTRICAL INSTALLATION

THE MICROSTEER SYSTEM COMES COMPLETE WITH A WIRING HARNESS (INCLUDING PROTECTION FUSE). THE HARNESS SHOULD BE CONNECTED AS FOLLOWS:

1. LARGE BLACK WIRE WITH RING CRIMP - BATTERY NEGATIVE
2. LARGE RED WIRE WITH RING CRIMP - BATTERY POSITIVE (12V DC ONLY)
3. SMALL BLACK WIRE - BATTERY NEGATIVE
4. SMALL RED WIRE - IGNITION +12V
5. CONNECT THE TWO MULTIPLUGS FROM THE WIRING HARNESS AND THE TWO MULTIPLUGS FROM THE MOTOR TO THE ECU. EACH IS A DIFFERENT STYLE AND WILL ONLY FIT IN ONE POSITION.
6. PLUG THE MICROSTEER HARNESS INTO THE TUNING BOX VIA THE 10-PIN CONNECTOR.

## WHEEL SPEED INPUT

IF YOU WOULD LIKE TO MAKE YOUR SYSTEM SPEED SENSITIVE, A 3-PIN WHEEL SPEED CONNECTOR IS PROVIDED ON THE MICROSTEER WIRING HARNESS. HOW YOU WIRE THE CONNECTOR DEPENDS UPON WHETHER YOU ALREADY HAVE A WHEEL SPEED SIGNAL PRESENT OR NOT. (THE FOLLOWING STEPS CAN BE DISREGARDED IF YOU ONLY INTEND TO USE YOUR MICROSTEER SYSTEM IN MANUAL MODE):

## WHEEL SPEED SIGNAL ALREADY PRESENT

IF YOUR VEHICLE ALREADY HAS A DIGITAL WHEEL SPEED SENSOR FITTED, LOCATE THE SENSOR SIGNAL WIRE. SPLICE THIS INTO (AND THEN CONNECT TO) THE MICROSTEER WHEEL SPEED CONNECTOR ON PIN 2 (THE BLUE WIRE). THE AIM HERE IS TO SHARE THE SIGNAL BETWEEN YOUR VEHICLE'S SPEEDOMETER AND THE MICROSTEER TUNING BOX.

## NO WHEEL SPEED SIGNAL PRESENT

IF YOU HAVE NO WHEEL SPEED SENSOR FITTED ON THE VEHICLE, YOU WILL NEED OUR EPAS200W MICROSTEER SPEED SENSOR, WHICH IS NOT INCLUDED IN THE FR40200 KIT. THE SENSOR IS FITTED TO THE WHEEL SPEED CONNECTOR AS FOLLOWS:

1. +12V
2. SIGNAL
3. GROUND

THE SENSOR SHOULD THEN BE MOUNTED ON THE VEHICLE TO MONITOR EITHER WHEEL OR PROP SHAFT ROTATION. THE NUMBER OF TARGETS PER REVOLUTION DOES NOT MATTER AS THE TUNING BOX WILL AUTOMATICALLY ADJUST FOR THIS.

## OPERATION: MANUAL MODE

A SMALL MODE SELECTION TOGGLE SWITCH IS FITTED TO THE TUNING BOX. MIDDLE POSITION IS WHEEL SPEED MODE, THE MOMENTARY POSITION AGAINST THE KEYWAY TO THE TOP OF THE BOX IS CALIBRATION MODE AND THE LATCHED POSITION OPPOSITE THE KEYWAY IS MANUAL MODE.

MOVE THE MODE SWITCH TO THE DOWNWARD POSITION. THE SYSTEM IS NOW READY FOR TESTING. ENSURE THE VEHICLE IS ON THE GROUND WITH THE WHEELS FITTED AND THE POTENTIOMETER TURNED FULLY COUNTER-CLOCKWISE. TURN ON THE IGNITION. THE RED LED IN THE WIRING HARNESS NEAR THE ECU AND THE STATUS LED ON THE TUNING BOX SHOULD BOTH FLASH ONCE THEN SWITCH OFF. TURN THE STEERING WHEEL AND YOU SHOULD HAVE MINIMAL POWER ASSISTANCE.

TURNING THE POTENTIOMETER CLOCKWISE WILL INCREASE THE LEVEL OF ASSISTANCE AVAILABLE AND THE STATUS LED ON THE TUNING BOX WILL BECOME BRIGHTER AS ASSISTANCE INCREASES.

## OPERATION: WHEEL SPEED MODE

ENSURE A WHEEL SPEED SIGNAL OR SENSOR IS CONNECTED TO THE WHEEL SPEED CONNECTOR AND THE IGNITION IS OFF.

- HOLD THE MODE SWITCH IN THE CALIBRATION POSITION (UPWARD)
- START THE ENGINE
- RELEASE THE CALIBRATION SWITCH. THE RED STATUS LED ON THE TUNING BOX WILL NOW FLASH.
- AT THIS POINT ELECTRIC ASSISTANCE IS AT ITS MINIMUM SETTING.
- DRIVE THE VEHICLE UNTIL YOU FEEL THE WEIGHT OF STEERING IS COMFORTABLE. BRIEFLY FLICK THE MODE SWITCH BACK UP TO THE CALIBRATION POSITION AND RELEASE. THIS SETS THE CALIBRATION SPEED.
- ABOVE THE CALIBRATION SPEED, ASSISTANCE IS MINIMAL AND THE STATUS LED IS UNLIT.
- BELOW THE CALIBRATION SPEED, ASSISTANCE WILL GRADUALLY INCREASE FROM MINIMUM AT THE CALIBRATION SPEED TO MAXIMUM WHEN THE VEHICLE IS STATIONARY - THE STATUS LED WILL GET BRIGHTER AS THE LEVEL OF ASSISTANCE INCREASES.

IF YOU FEEL YOU NEED MORE ASSISTANCE AT A LOWER SPEED, SIMPLY REPEAT THE ABOVE PROCEDURE AND MOVE THE CALIBRATION POINT TO A HIGHER SPEED.

## MODE SELECTION SWITCH

THE MICROSTEER TUNING BOX HAS BEEN SPECIFICALLY DESIGNED TO ALLOW YOU TO SWAP BETWEEN MANUAL OR WHEEL SPEED MODES WHILE ON THE MOVE. PLEASE NOTE THAT SWITCHING FROM WHEEL SPEED TO MANUAL MODE AT HIGH SPEEDS COULD RESULT IN VERY LIGHT STEERING DEPENDING ON THE POSITION OF THE POTENTIOMETER.

## TAKE CARE WHILE SWITCHING MODES ON THE MOVE! FAULT LED

A SMALL RED LED IS FITTED TO THE WIRING HARNESS NEAR THE ECU. IN NORMAL OPERATIONS THIS WILL FLASH ONCE ON POWER UP THEN SWITCH OFF. IN THE UNLIKELY EVENT OF AN EPAS FAULT THIS LED WILL FLASH A CODE. IF THIS OCCURS, PLEASE CONSULT YOUR SUPPLYING DEALER FOR ASSISTANCE.



MICROSTEER TECHNICAL SPECIFICATION	
Operating Voltage:	Nominal 13.8V DC
Maximum current draw:	30 Amps
Average current draw - Amps (normal urban use):	Less than 2 Amps
System Weight: MGU & ECU	4.4kg / 9.70lbs
Maximum Torque Output:	32Nm / 24lb.ft
IP Rating:	IP67
Operating Temperature:	-20 to 120°C / -4 to 248°F
Motor Rated Power	220 Watt
MGU Spline Pattern	11/16" 36 both ends

### IMPORTANT INFORMATION

- THE STEERING SYSTEM OF A VEHICLE IS A SAFETY CRITICAL COMPONENT AND MODIFICATION OF THIS SYSTEM SHOULD ONLY BE CARRIED OUT BY A COMPETENT PERSON.
- THE MGU MUST BE MOUNTED IN THE CORRECT ORIENTATION OR IT WILL NOT FUNCTION. PLEASE SEE DIMENSIONS DRAWING FOR CLARIFICATION ON THE THE INPUT AND OUTPUT SPLINES.
- THE ELECTRIC MOTOR CAN BE MOUNTED SO IT POINTS UP, DOWN, LEFT OR RIGHT TO SUIT YOUR INSTALLATION NEEDS.
- ENSURE THE UNIT IS ADEQUATELY MOUNTED - A TORSIONAL FORCE IN EXCESS OF 60NM/45LB.FT. CAN EASILY BE GENERATED BY THE DRIVER AND STEERING SYSTEM COMBINED.
- DO NOT WELD UPON ANY PART OF THE MICROSTEER MOTOR OR ECU - ELECTRONICS ARE CONTAINED WITHIN THE UNITS THAT WILL BE DAMAGED BY THIS PROCESS.
- THE MICROSTEER SYSTEM IS NOT SUITABLE FOR VEHICLES THAT REQUIRE ANY CONTROLS TO PASS ALONG THE INSIDE OF THE STEERING COLUMN AS THE SHAFT IS SOLID.

### DIMENSIONS

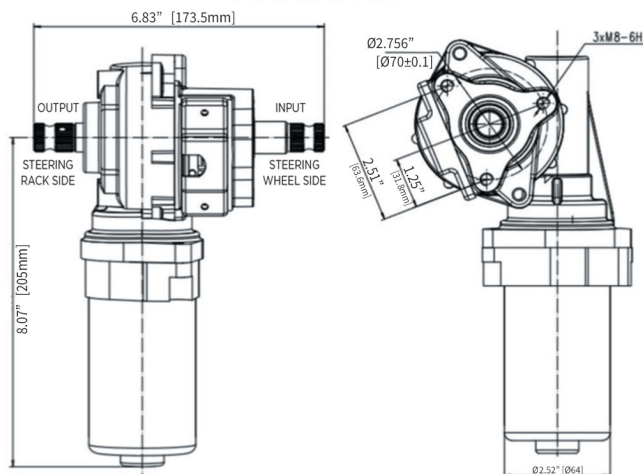

REV: 062819

5

P/N: 102876

### FLAMING RIVER WARRANTY INFORMATION

Flaming River warrants its products to be free from defects in material and workmanship for a period of one (1) year after the date of purchase, except that: All steering columns are warranted for a period of three (3) years from the date of purchase. The Big Switch and Big Switch 500 (part numbers FR1044/FR1046/FR1047) are warranted for a period of three (3) years from the date of purchase, provided that it is not mounted with a steel bracket and provided further that it is adequately protected from environmental conditions. All electrical products other than the Big Switch are warranted for a period of ninety (90) days from the date of purchase. Flaming River's warranty liability is limited to the replacement of defective products. Flaming River is not liable for any labor costs associated with any warranty claim, or for any incidental or consequential damages. Improper installation, abuse, racing, and/or modification of the products voids this warranty. No warranty of merchantability or fitness for a particular purpose is made by Flaming River with respect to any of its products.

### Warnings and Recommendations

It is the customer's responsibility to determine the suitability of a given Flaming River product for the customer's uses. Likewise, it is the customer's responsibility to install a Flaming River product. Contact the vehicle manufacturer when ever installing a switch to confirm the appropriateness of using such a switch and the recommended placement of the switch on the vehicle. Use qualified chassis specialists for the installation of all steering related components. Be aware that the installation of certain Flaming River products may adversely impact a manufacturer's warranty with respect to certain vehicles and other manufactured goods. Flaming River will repair or replace any product found to be defective in material or workmanship. Improper installation, abuse, racing and/or modification **VOID WARRANTY**. Flaming River is not responsible for any labor costs associated with any warranty.

**Note:** The information contained in this catalog is correct to the best of our knowledge and belief, having been compiled from reliable and official sources of information. However, Flaming River Industries, Inc. cannot assume responsibility for possible error.



FLAMING RIVER INDUSTRIES, INC.  
 800 POERTNER DR. BERA, OH 44017  
 (800)648-8022 · (440)826-4488  
 WWW.FLAMINGRIVER.COM

REV: 062819

6

P/N: 102876



STEERING YOU IN THE RIGHT DIRECTION®

### FLAMING RIVER MICROSTEER (FR40200) USER GUIDE

FLAMING RIVER MICROSTEER IS A UNIVERSAL ELECTRIC POWER ASSISTED STEERING (EPAS) SYSTEM. IT CAN BE EASILY FITTED TO VIRTUALLY ANY VEHICLE'S MANUAL STEERING SETUP WITHOUT THE NEED TO CHANGE THE STEERING RACK OR FIT A HYDRAULIC SYSTEM WHERE MANUAL STEERING CURRENTLY EXISTS.



UNIVERSAL JOINTS AVAILABLE IN CHROMOLY OR PINCH BOLT AND ARE NOT INCLUDED IN THE EPAS KIT.

THE STANDARD MICROSTEER KIT (PICTURED ABOVE) COMPRISES THE FOLLOWING:

- MOTOR/GEARBOX (MGU)
- ELECTRONIC CONTROL UNIT (ECU)
- TUNING BOX
- WIRING HARNESS
- INPUT AND OUTPUT SHAFTS

REV: 062819

1

P/N: 102876