

Product Name: **WG30/40/45 Valve Position Sensor**
Product Description: Valve Position Sensor WG38/40/45
Part Numbers: TS-0502-3014, TS-0502-2008, TS-0502-2009



IMPORTANT NOTES ON INSTALLATION OF YOUR WASTEGATE SENSOR CAP, SENSOR AND SENSOR PLUG

- Fitting your sensor cap may require fabrication or modification to your existing setup. Turbosmart recommends that your sensor cap is fitted by an appropriately qualified technician.
 - Turbosmart recommends that a qualified auto electrician completes the installation of the sensor plug.
-

WASTEGATE 38/40/45 VALVE POSITION SENSOR CAP

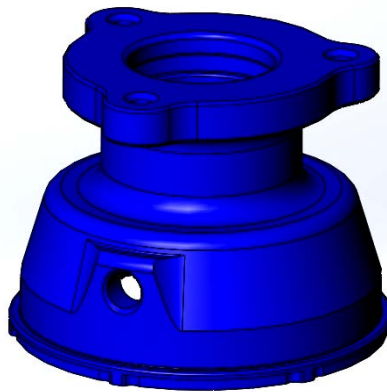

- The cap is designed to be a straight replacement to the original wastegate cap. No modifications are required for fitment.
- The "top port" is incorporated in the valve position sensor cap design. Pressure may still be supplied to the top port to help close the wastegate valve.
- The valve position sensor (TS-0502-2008) and valve position sensor plug (TS-0502-2009) are sold separately.

Changing the wastegate caps

WARNING! Use caution when changing the wastegate caps.

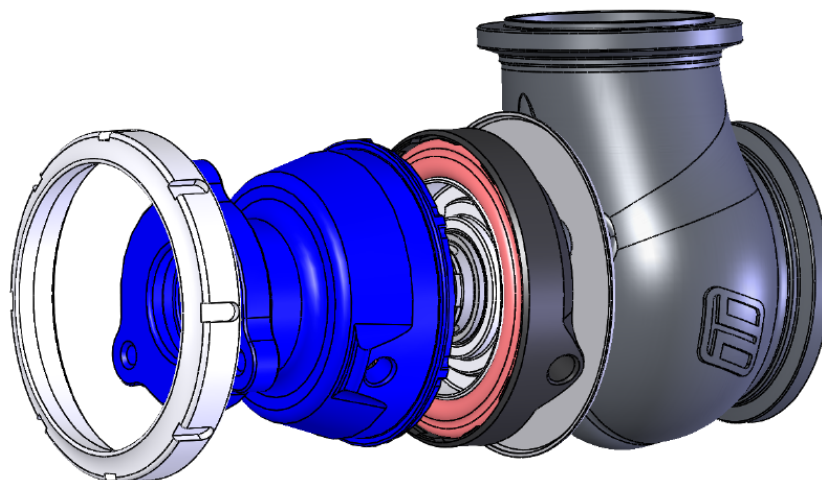

IMPORTANT: A press or clamping device must be used when removing or installing the collar as clamping the cap down removes the load off the collar and allows it to be removed. The following are examples of different clamping devices that can be used to remove or install the collar:

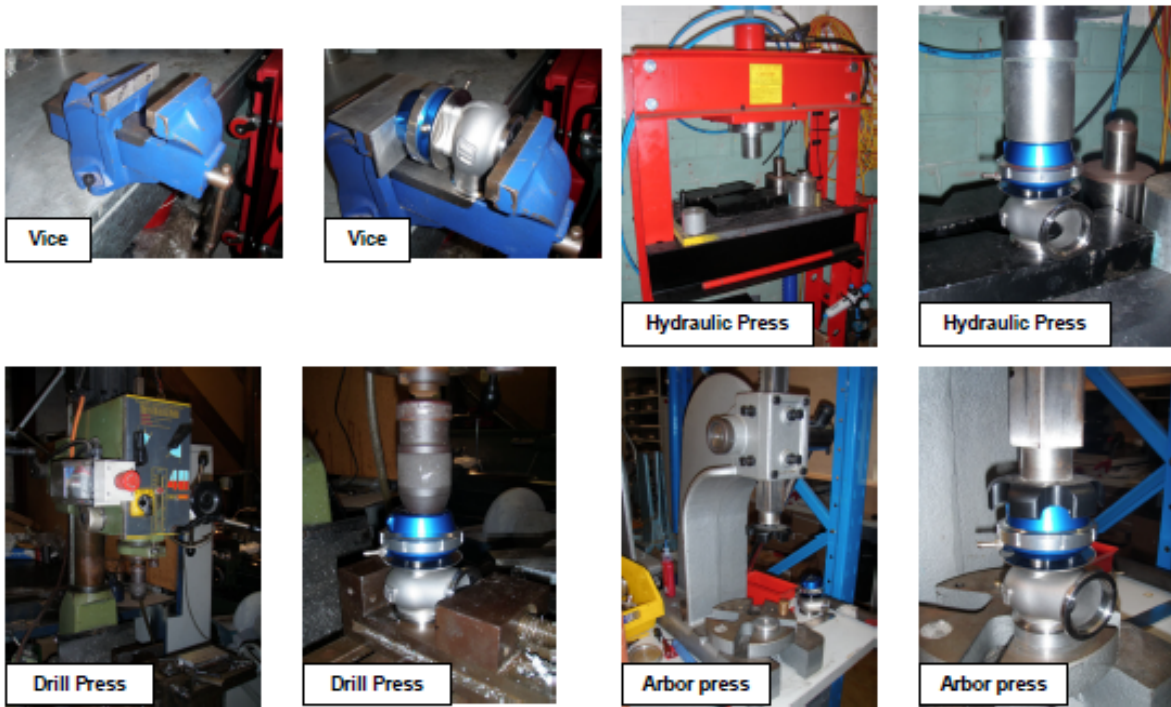

- 1) Remove the wastegate from the exhaust manifold. Use **CAUTION!** The wastegate may still be **HOT!**
- 2) Remove any pressure nipples in the top cap. Hold the cap down in a press or vice. Using the locking collar tool, unscrew the locking collar. Slowly, back off the vice or press and remove the cap.
- 3) Ensure that the diaphragm is inside the diaphragm groove.
- 4) Slowly push the sensor cap down on the lower diaphragm housing in a vice or press. As the cap reaches the diaphragm, line up the notches in the cap with the cut outs in the lower diaphragm housing. Carefully push the cap down till the cap is home on the lower diaphragm housing. Reinstall the locking collar and tighten with the locking tool. Make sure that the cap is clamped down while tightening the collar.

Wiring the sensor plug

WARNING! Use caution when soldering the wires.

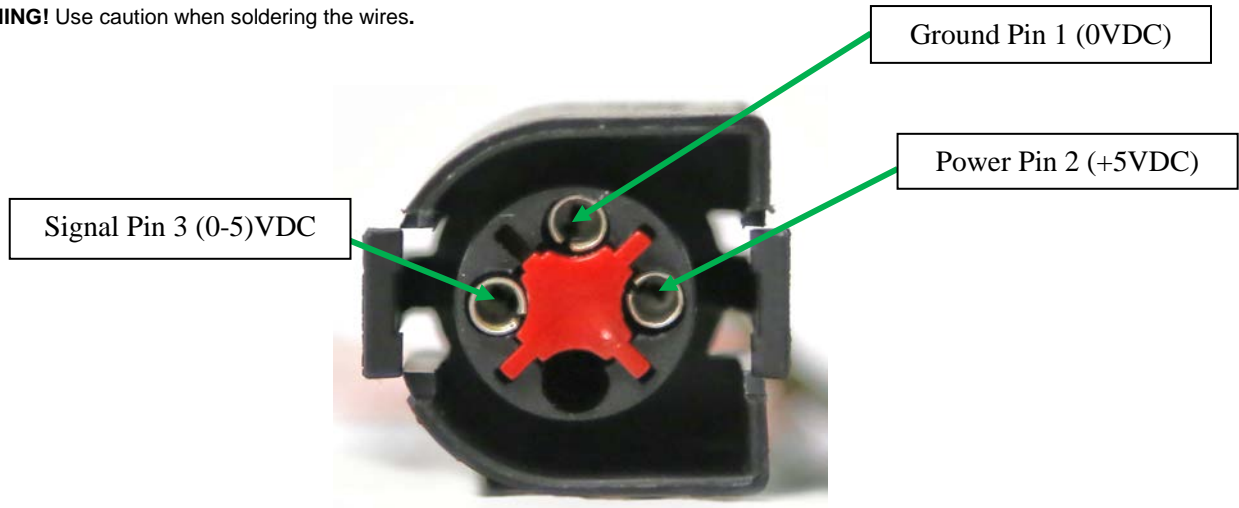

- The valve position sensor plug has three wire ends. The first terminal is for positive voltage supply (+5VDC, black and green wire), the second terminal is for ground supply (0VDC, black and white wire) and the third terminal is the positive variable voltage return (0-5 VDC).
- Connect the wires to your data logger accordingly. Use a solder iron and heat shrink insulation when joining the wire ends.
- Gently inset the plug into the sensor. The plug can only be inserted in one way. Check for plug and sensor orientation. Do not force the plug into the sensor.
- Test the wiring. Gently push the sensor pin up and down and ensure that the voltage input on the data logger is changing between 0-5 VDC. The data logger should approximately read 0 VDC when the sensor pin is in free form and approximately +5VDC when the sensor pin is pushed all the way in.
- Ensure that the wiring is properly shielded from external heat sources.

Installing the valve position sensor

WARNING! Use caution when installing the valve position sensor.

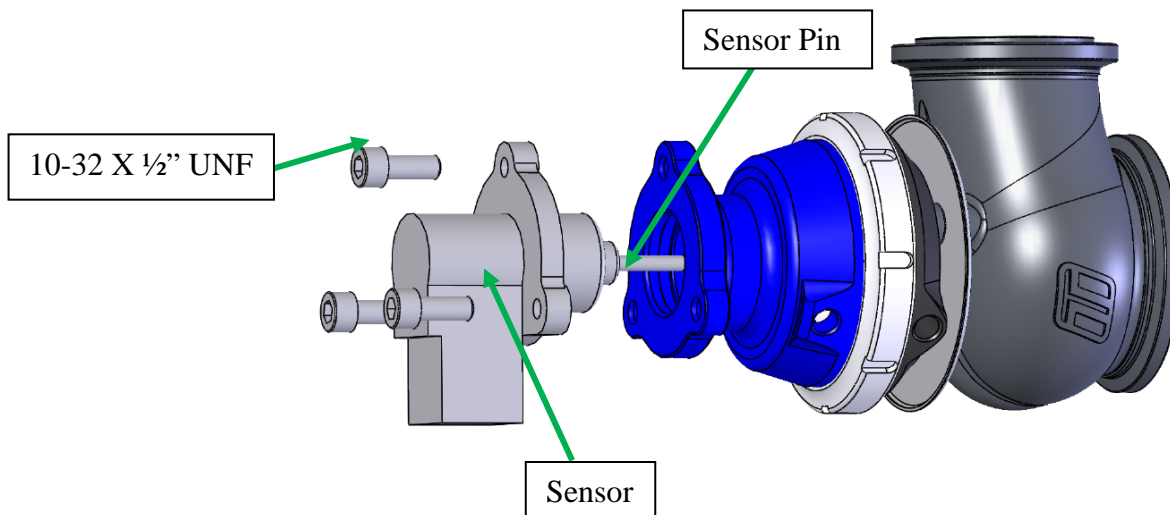

- Insert sensor into cap. Rotate left and right as you are pushing the sensor in. Ensure that the screw holes in the sensor body are aligned with the tapped screw holes on the sensor cap in your desired position.
- Use supplied screws to screw the sensor to the cap. Torque screws to 2 N-m (1.5 lb-ft). Be careful not to over tighten the screws as it will damage the sensor.

The Turbosmart Pledge

TURBOSMART ONE YEAR LIMITED WARRANTY

Turbosmart is a company built on Customer Satisfaction and Service. That is why all of our products go through regimented test procedures before they are packaged and shipped. Turbosmart stands behind its products for one full year after purchase. Terms of Warranty, Service and Returns are as follows:

Limited Warranty: Turbosmart warrants its products to be free from defects in material and workmanship under normal use and if properly installed for a period of one year from date of purchase. If found to be defective, it will be replaced or repaired if returned prepaid along with proof of date of purchase. This shall constitute the sole remedy of the purchaser and the sole liability of Turbosmart to the extent permitted by law, the foregoing is exclusive and in lieu of all other warranties or representations whether expressed or implied, including any implied warranty of merchantability or fitness. In no event shall Turbosmart be liable for special or consequential damages. This warranty is only valid on products purchased from Turbosmart Authorized Dealers.

Service: After the warranty period has expired, repair service is charged based on a minimum and maximum charge rate. (Contact Customer Service for current rate).

Returns: When returning a Turbosmart product for repair, it must be accompanied by a completed Customer Warranty Form and RMA number. To access this form please go to our website www.turbosmartonline.com and you will find it on the Downloads page.

THE TURBOSMART PLEDGE

DO NOT USE ANY TURBOSMART PRODUCT UNTIL YOU HAVE CAREFULLY READ AND UNDERSTOOD THE FOLLOWING AGREEMENT.

Please call if you have any questions or do not understand this agreement. Refer to our brochure, website or catalogue for terms and conditions and further information regarding your product. Turbosmart appreciates your business and pride ourselves on our customer service. We are always happy to offer you advice and will provide you with help in any way we can. The purpose of this agreement is to avoid any problems or hard feelings.

We sometimes make mistakes, as do our dealers, distributors and suppliers. Even customers can sometimes order the wrong parts. Do not use, modify, install, trial assemble, nick, drop, scratch or adjust any part until you first check for any damage. Damage must be reported immediately. NO EXCEPTIONS. If there are any components missing please contact your authorized reseller immediately upon receipt of your shipment. Missing components must be reported within five (5) business days of receipt. Parts returned for any reason MUST BE IN RESALABLE CONDITION. It is YOUR responsibility, "THE CUSTOMER" to carefully package any returns to avoid shipping damage. Insurance is highly recommended. Credit cannot be issued for damaged goods.

Turbosmart warrants the quality of the products it designs and manufactures to be free of defects in material and workmanship. This limited warranty is extended only to the original purchaser and may not be transferred or assigned. This limited warranty applies to any product, which after careful inspection by Turbosmart, after receipt of the product from our authorized reseller, is found to have a defect in either material or workmanship. Any modifications to the product will void any and all warranties and will not be exchanged. Before installation, check new car warranty. Turbosmart is not responsible for voiding any original manufactures warranty.

All warranty claims must be returned to the nearest Turbosmart Office, you must return the product and sales receipt, at your own expense, accompanied by the Customer Warranty Form stating the reason for the claim. Proof of purchase must be provided with any warranty claim and will be verified with the authorized reseller from which the product was purchased.

If all the above procedures are followed, and the product is found to be defective in either workmanship or material, Turbosmart shall either repair or replace the product, at its sole discretion, and sole cost. This limited warranty does not cover or apply to any personal injury, labor charges or any other incidental costs or damages caused by the defective product. The individual purchaser acknowledges and agrees that the disclaimer of any liability for personal injury is a material term for this agreement and the individual purchaser agrees to indemnify Turbosmart and to hold Turbosmart harmless for any claim related to the item of the equipment purchased. Under no circumstances will Turbosmart be liable for any damages or expenses by reason of use or sale of any such equipment.

THIS LIMITED WARRANTY IS THE ONLY EXPRESS WARRANTY, WHICH APPLIES TO TURBOSMART PRODUCT AS EXPRESSLY GIVEN IN LIEU OF ANY OTHER WARRANTY EXPRESSED OR IMPLIED, INCLUDING THAT OF MERCHANTABILITY. ANY IMPLIED WARRANTY INCLUDING THAT OF MERCHANTABILITY AND/OR FITNESS FOR A PARTICULAR PURPOSE IS HEREBY LIMITED BY THE SAME TERMS AND TIME LIMITATIONS SET FORTH IN THIS LIMITED EXPRESS WARRANTY AND OTHERWISE EXCLUDED. EXCEPT FOR THOSE OBLIGATIONS ASSUMED HEREIN, TURBOSMART ASSUMES NO OTHER OBLIGATIONS IN CONNECTION WITH THE SALE OF ITS PRODUCTS.

IN THE EVENT THAT THE INDIVIDUAL PURCHASER DOES NOT AGREE WITH THIS AGREEMENT THE BUYER MAY PROMPTLY RETURN THIS PRODUCT, IN A NEW AND UN-USED CONDITION, WITH A DATED PROOF OF PURCHASE, TO THE PLACE OF PURCHASE WITHIN SEVEN (7) DAYS FROM THE DATE OF PURCHASE FOR A FULL REFUND. THE INSTALLATION OF THIS PRODUCT INDICATES THAT THE INDIVIDUAL PURCHASER HAS READ AND UNDERSTOOD THIS AGREEMENT AND ACCEPTS ITS TERMS AND CONDITIONS.

Happy motoring!
The Turbosmart Team.