

# Installation Instructions

I - Sheet Number VV30 Rev.A



AUTO VENT SHADE™

## Ventvisor® Deflector

**For proper installation and best possible fit, please read all instructions BEFORE you begin.  
For technical assistance or to obtain missing parts, please call Customer Relations at 1-800-241-7219.**

### Important Safety Information



- CAUTION - Before driving, ensure that the vent visors are properly secured to vehicle.
- Do not use automatic “brush-style” car washes.
- Do not use cleaning solvents of any kind.
- Periodically check all components for tightness.
- When using Surface Prep, avoid contact with skin. Use in well ventilated area. If contact is made with material, flush area with large amounts of water. If irritation persists, get immediate medical attention. USE PREP ON RUBBER ONLY

### Contents - 2 Piece Set **NOTE:** Actual product may vary from illustration.



Front Driver Side Visor



Front Passenger Side Visor

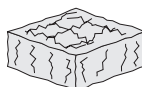

Scotch Brite Pad



Alcohol Pad x2



Surface Prep x1

### Contents - 4 Piece Set



Front Driver Side Visor



Front Passenger Side Visor



Rear Driver Side Visor



Rear Passenger Side Visor

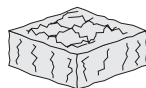

Scotch Brite Pad



Alcohol Pad x2



Surface Prep x2

### Tools Required



Car Wash Supplies



Clean Towel

### Preparation Before Painting / Installation

- A trial fit is recommended to ensure proper positioning and fit.
- Check fit of parts before painting as we will not accept the return of modified or painted parts.
- Wash and dry your vehicle to remove any debris and/or dirt from the installation area.

# Installation Steps

**NOTE:** Actual application may vary slightly from illustrations.

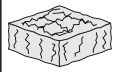

Scuff rubber mounting surface.

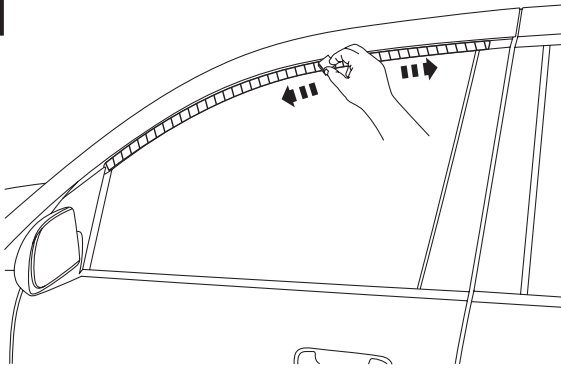

1



Clean mounting surface.

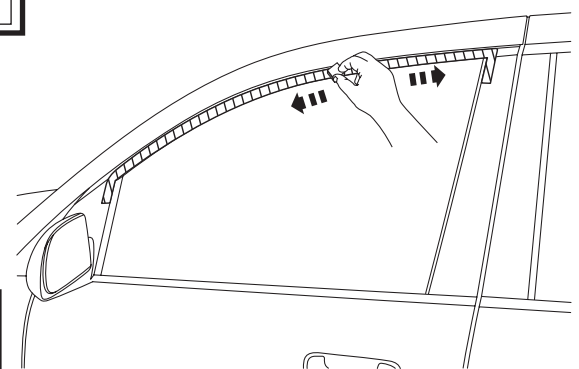

2



Apply surface prep to rubber surface.

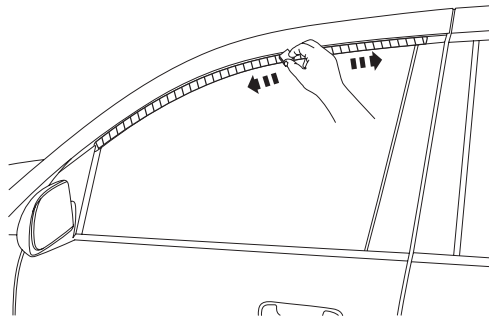

3

**CAUTION:** Read surface prep warning on page 1 before continuing.

Remove tape liner from front & rear flanges. Peel back 2" (5 cm) of tape liner from each end of top flange.

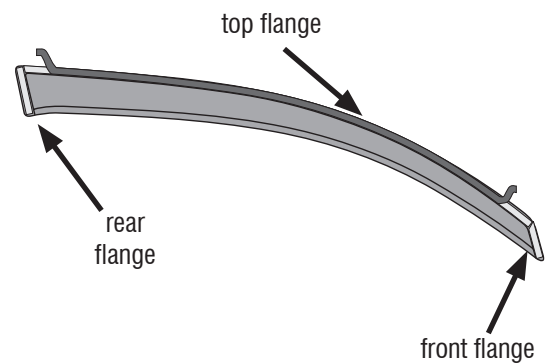

4

Attach visor to door while making sure all areas of the mounting surface are flush. **It may be necessary to open the door and apply pressure from behind the top of the frame to ensure a flush mounting surface.**

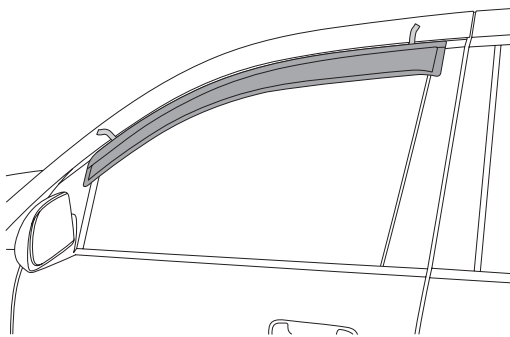

5

Remove tape liner and apply pressure to tape flanges to secure.

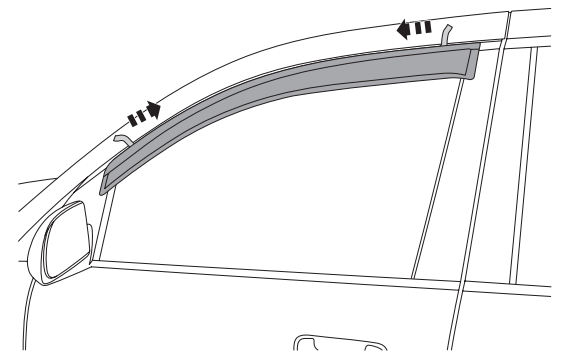

6

## Installation Steps - 4 Piece Set

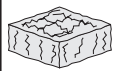

Scuff rubber mounting surface.

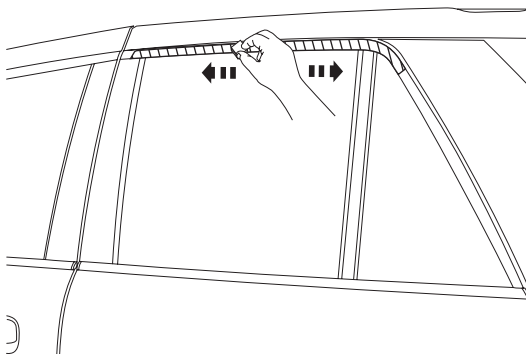

7



Clean mounting surface.

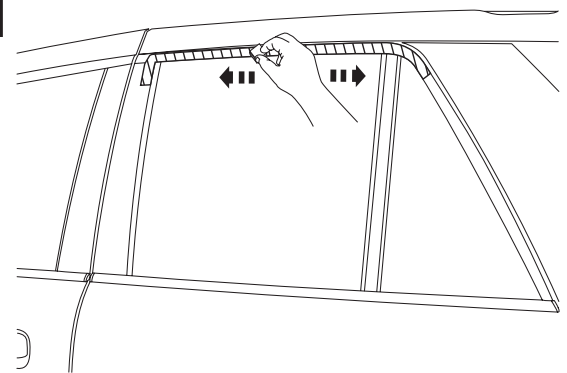

8

## Installation Steps

**NOTE:** Actual application may vary slightly from illustrations.

SURFACE PREP  
A 4298  
PART #  
12368011

Apply surface prep to rubber surface.

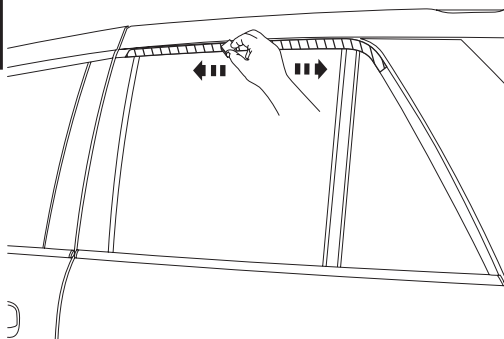

9

**CAUTION:** Read surface prep warning on page 1 before continuing.

Remove tape liner from front & rear flanges. Peel back 2" (5 cm) of tape liner from each end of top flange.

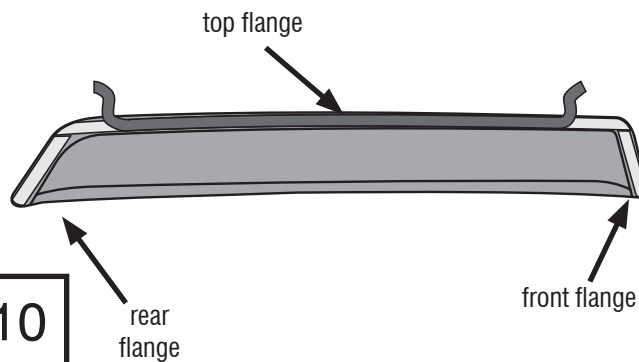

10

Attach visor to door while making sure all areas of the mounting surface are flush. **It may be necessary to open the door and apply pressure from behind the top of the frame to ensure a flush mounting surface.**

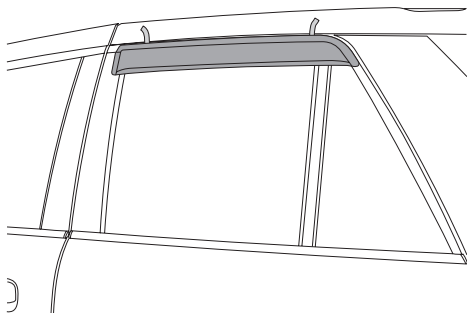

11

Remove tape liner and apply pressure to tape flanges to secure.

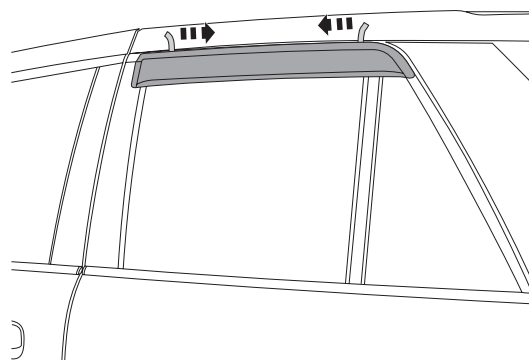

12

Repeat **Steps 1-12** for passenger side.

## Care and Cleaning

- Wash only with mild soap & dry with a clean cloth.

## Congratulations!

You have purchased one of the many quality Auto Ventshade™ branded products offered by Lund International, Inc. We take the utmost pride in our products and want you to enjoy years of satisfaction from your investment. We have made every effort to ensure that your product is top quality in terms of fit, durability, finish and ease of installation.



AUTO VENTSHADE™

Lund International, Ventshade Accessories Division

655 Raco Drive, Lawrenceville, GA 30045

800-241-7219 • Fax 770-339-5839 • Visit us at [lundinternational.com](http://lundinternational.com)



© 2005 Lund International, Inc. All rights reserved.

Auto Ventshade™, the Auto Ventshade™ logo and the AVS™ logo are trademarks of Lund International, Inc.





AUTO VENTSHADE™

## Ventvisor® Deflector

**Pour obtenir une installation correcte et le meilleur ajustement possible, lire toutes les instructions AVANT de commencer. Pour toute assistance technique ou obtention de pièces manquantes, appeler le service des relations avec la clientèle au 1-800-241-7219.**

### Informations importantes concernant la sécurité



- ATTENTION – Avant de conduire, s'assurer que la visière est solidement assujettie sur le véhicule.
- Ne pas utiliser les stations de lavage de voitures à brosses.
- Ne pas utiliser de solvants.
- Vérifier régulièrement le serrage des composants.

### Contenu - Ensemble 2 pièces

**NOTE:** Le produit réel peut changer de l'illustration.



Visière avant côté conducteur



Visière avant côté passager



tampon à récurer  
Scotch Brite



Tampons à l'alcool  
(2)



Préparation Extérieure  
(1)

### Contenu - Ensemble 4 pièces



Visière avant côté conducteur



Visière avant côté passager



Visière arrière côté conducteur



Visière arrière côté passager

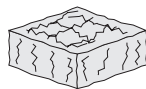

Scotch Brite  
Pad



Tampons à  
l'alcool (4)



Préparation Extérieure  
(2)

### Outils nécessaires



Fournitures pour lavage de voiture



Serviette propre

### Préparation pour la peinture/l'installation

- Il est recommandé de procéder à un essai pour s'assurer que le positionnement et l'ajustement sont corrects.
- Vérifier l'ajustement des pièces avant peinture, car nous n'acceptons pas le retour de pièces modifiées ou peintes.
- Laver les glissières de glaces de la portière du véhicule pour éliminer toute poussière et tous débris.
- Sécher les glissières avec une serviette propre.

## Étapes d'installation

REMARQUE : La méthode d'application peut être légèrement différente de celle représentée par les illustrations.



Frotter la surface de montage en caoutchouc.

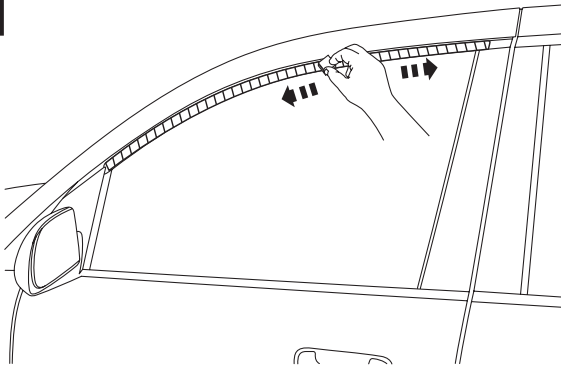

1



Nettoyer la surface de montage.

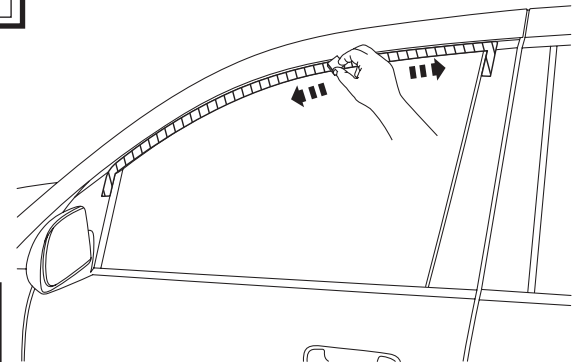

2

SURFACE PREP  
A 4298  
PART 2  
12368011

Enduire la surface en caoutchouc de produit de préparation de la surface.

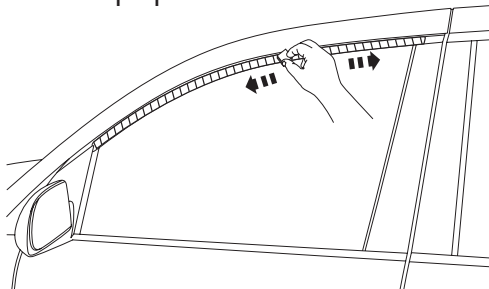

3

**ATTENTION: Avant de poursuivre, lire l'avertissement relatif au produit de préparation de la surface, à la page 1.**

Retirer la protection d'adhésif des rebords avant et arrière. Décoller environ 5 cm (2 po) de protection d'adhésif à chaque extrémité du rebord supérieur.

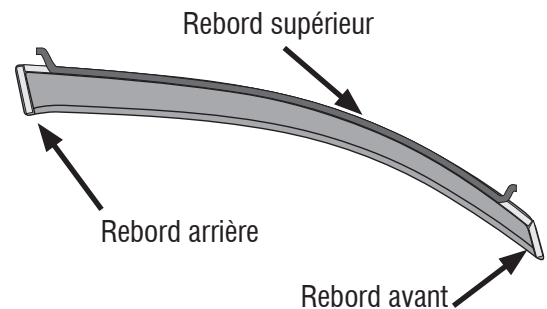

4

Fixer la visière sur la portière tout en s'assurant que toutes les parties de la surface de montage sont bien au ras. Il sera éventuellement nécessaire d'ouvrir la portière et de faire pression depuis l'arrière de la partie supérieure de l'encadrement pour s'assurer que la surface de montage est bien au ras.

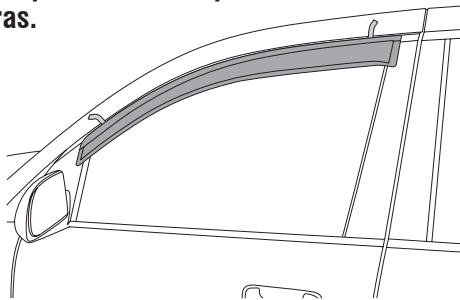

5

Retirer la protection d'adhésif et appuyer sur les rebords du ruban adhésif pour bien le faire adhérer.

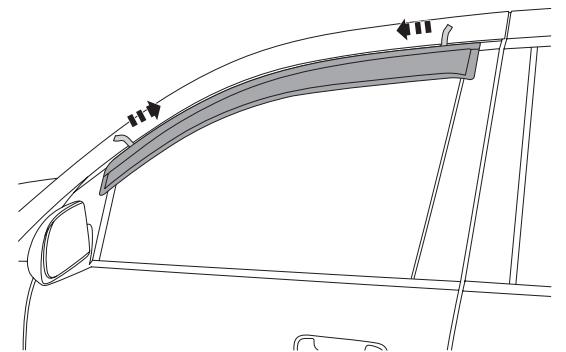

6

## Étapes d'installation - Ensemble 4 pièces

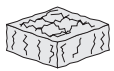

Frotter la surface de montage en caoutchouc.

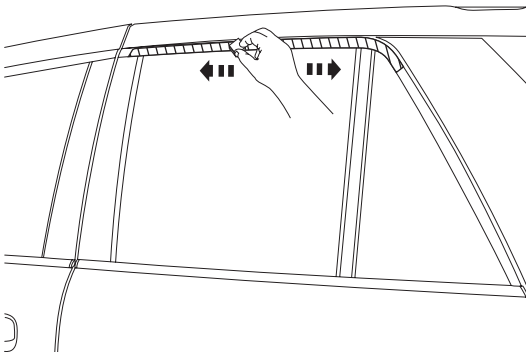

7



Nettoyer la surface de montage.

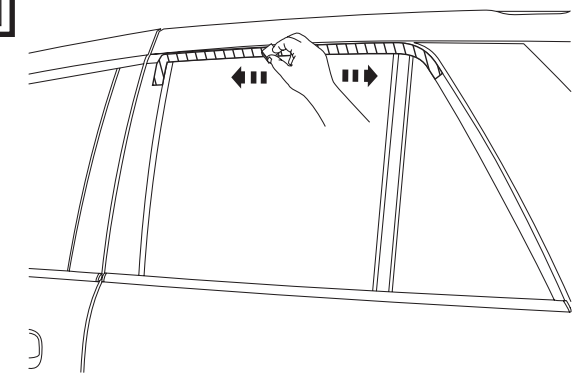

8

## Étapes d'installation

REMARQUE : La méthode d'application peut être légèrement différente de celle représentée par les illustrations.

SURFACE PREP  
A 4298  
PART #  
12368011

Enduire la surface en caoutchouc de produit de préparation de la surface.

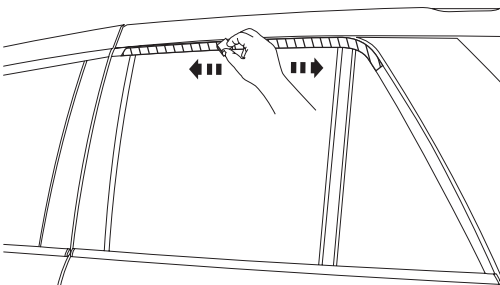

9

**ATTENTION: Avant de poursuivre, lire l'avertissement relatif au produit de préparation de la surface, à la page 1.**

Retirer la protection d'adhésif des rebords avant et arrière. Décoller environ 5 cm (2 po) de protection d'adhésif à chaque extrémité du rebord supérieur.

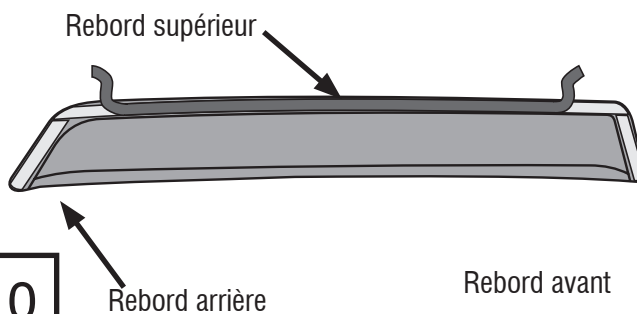

10

Fixer la visière sur la portière tout en s'assurant que toutes les parties de la surface de montage sont bien au ras. Il sera éventuellement nécessaire d'ouvrir la portière et de faire pression depuis l'arrière de la partie supérieure de l'encadrement pour s'assurer que la surface de montage est bien au ras.

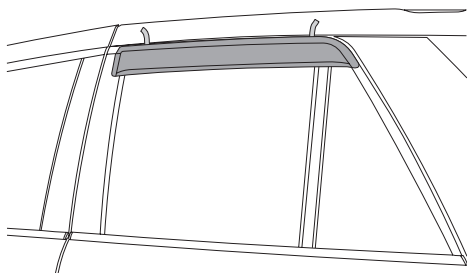

11

Retirer la protection d'adhésif et appuyer sur les rebords du ruban adhésif pour bien le faire adhérer.

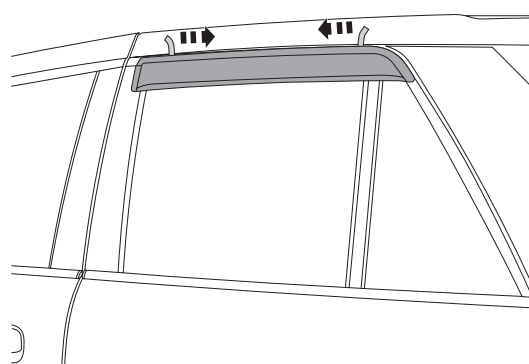

12

Répéter les **étapes 1 à 12** pour le côté passager.

## Entretien et nettoyage

- Laver exclusivement avec de l'eau savonneuse et sécher avec un chiffon propre.

## Félicitations !

Vous avez acheté l'un des nombreux produits de qualité Auto Ventshade™ fabriqués par Lund International, Inc. Nous sommes extrêmement fiers de nos produits et souhaitons que vous tiriez des années de satisfaction de votre investissement. Nous avons pris toutes les mesures nécessaires pour assurer que ce produit est d'une qualité supérieure en ce qui concerne l'ajustement, la durabilité, la finition et la facilité d'installation.



AUTO VENTSHADE™

Lund International, Ventshade Accessories Division

655 Raco Drive, Lawrenceville, GA 30045, USA

800-241-7219 • Fax 770-339-5839 • Visitez notre site [lundinternational.com](http://lundinternational.com)



© 2005 Lund International, Inc. Tous droits réservés.  
Auto Ventshade™, le logo Auto Ventshade™ et le logo AVS™ sont des marques déposées de Lund International, Inc.





AUTO VENTSHADE™

## Ventvisor® Deflector

Para una instalación adecuada y el mejor ajuste posible, lea todas las instrucciones ANTES de comenzar. Si desea recibir asistencia técnica u obtener piezas faltantes, llame al Servicio al cliente al 1-800-241-7219.

### Información importante de seguridad



- PRECAUCIÓN - Antes de conducir, asegúrese de que la visera esté correctamente anclada al vehículo.
- No utilice servicios automáticos de limpieza de vehículos que utilizan cepillos.
- No utilice limpiadores al solvente de ningún tipo.
- Compruebe periódicamente que todos los componentes estén ajustados.

### Contenido - Juego de dos piezas

NOTA: El producto real puede variar de la ilustración.



Visera delantera del conductor



Visera delantera del acompañante

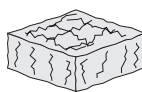

el paño Scotch Brite



Paños esterilizados x 2



Preparación Superficial

### Contenido - Juego de cuatro piezas

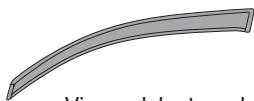

Visera delantera del conductor



Visera delantera del acompañante



Visera trasera del conductor



Visera trasera del acompañante

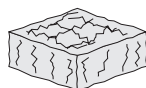

el paño Scotch Brite



Paños esterilizados x 4



Preparación Superficial x 2

### Herramientas necesarias



Equipo de limpieza de vehículos



Toalla limpia

### Preparación antes de pintar o instalar

- Se recomienda realizar un ajuste de prueba para asegurar el posicionamiento y ajuste correctos.
- Compruebe que las piezas se ajusten correctamente antes de pintarlas, ya que no aceptaremos la devolución de piezas modificadas o pintadas.
- Lave los canales de la ventanilla del vehículo para quitar los desechos y la suciedad.
- Seque los canales de la ventanilla con una toalla limpia.



## Pasos de instalación

**AVISO:** La colocación real puede variar con respecto a las ilustraciones.



Restriegue la superficie de colocación de la goma.

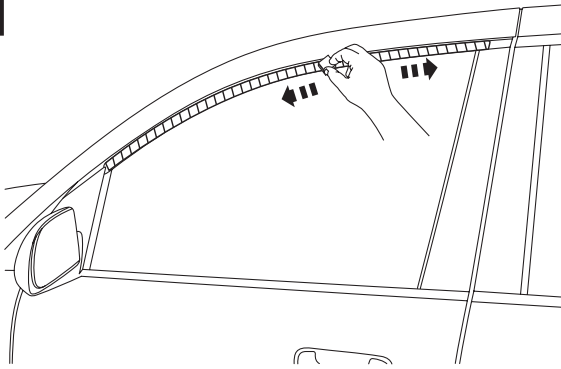

1



Limpie la superficie de colocación

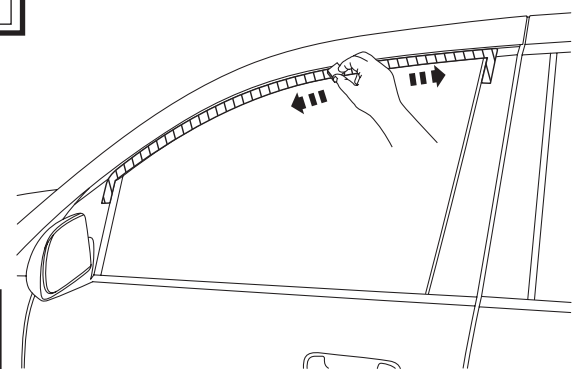

2

SURFACE PREP  
A 4298  
PART #  
12368011

Aplique preparador de superficies a la superficie de goma.

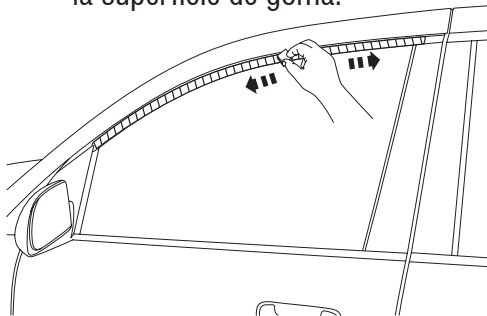

3

**PRECAUCIÓN:** Lea la advertencia del preparador de superficie en la página 1 antes de continuar.

Quite la cinta protectora de los rebordes frontales y traseros. Retire 2 pulgs. (5 cm) de cinta protectora de cada uno de los extremos del reborde superior.

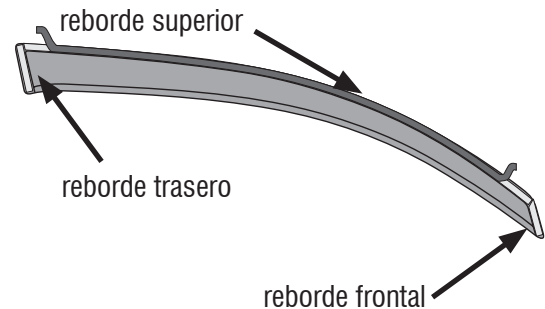

4

Coloque la visera en la puerta asegurándose de que todas las áreas de la superficie de colocación estén niveladas. Es posible que deba abrir la puerta y aplicar presión desde la parte trasera de la parte superior del marco para asegurar una superficie de colocación nivelada.

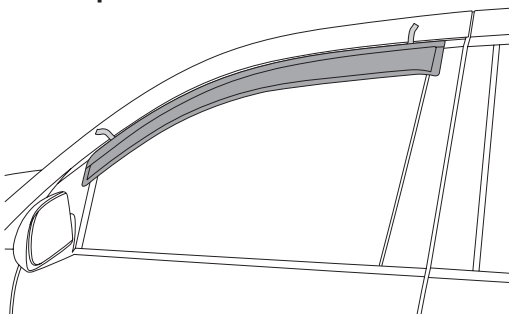

5

Retire la cinta protectora y aplique presión a los rebordes de la cinta para fijar.

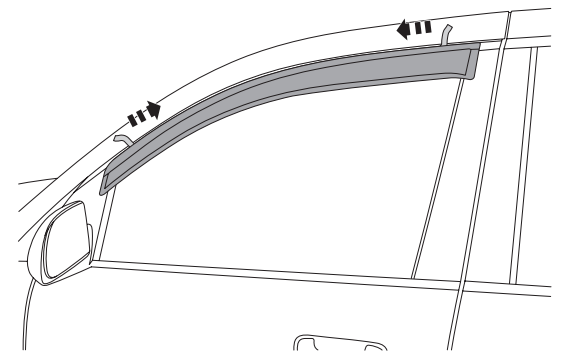

6

## Pasos de instalación - Juego de cuatro piezas



Restriegue la superficie de colocación de la goma.

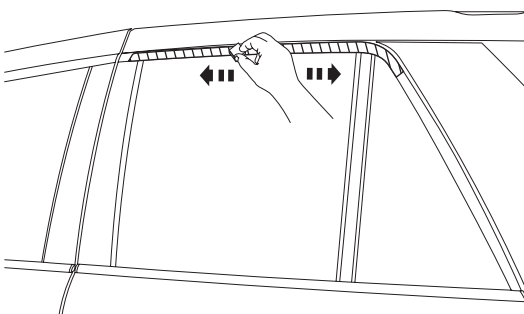

7



Limpie la superficie de colocación

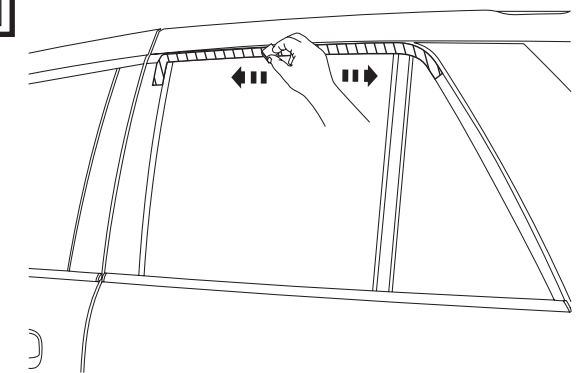

8



## Pasos de instalación

**AVISO:** La colocación real puede variar con respecto a las ilustraciones.

SURFACE PREP  
A 4298  
PART #  
12368011

Aplique preparador de superficies a la superficie de goma.

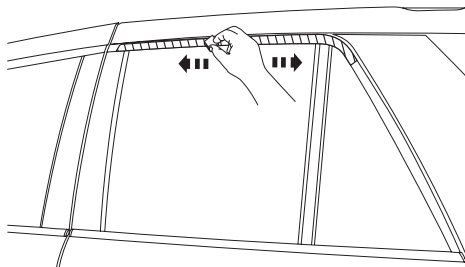

9

**PRECAUCIÓN:** Lea la advertencia del preparador de superficie en la página 1 antes de continuar.

Quite la cinta protectora de los rebordes frontales y traseros. Retire 2 pulgs. (5 cm) de cinta protectora de cada uno de los extremos del reborde superior.

reborde superior

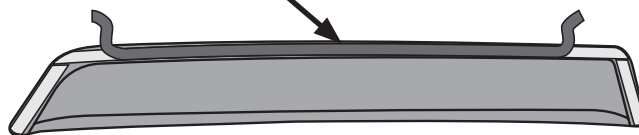

10

reborde trasero

reborde frontal

Coloque la visera en la puerta asegurándose de que todas las áreas de la superficie de colocación estén niveladas. Es posible que deba abrir la puerta y aplicar presión desde la parte trasera de la parte superior del marco para asegurar una superficie de colocación nivelada.

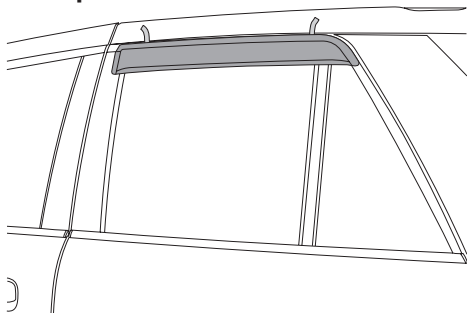

11

Retire la cinta protectora y aplique presión a los rebordes de la cinta para fijar.

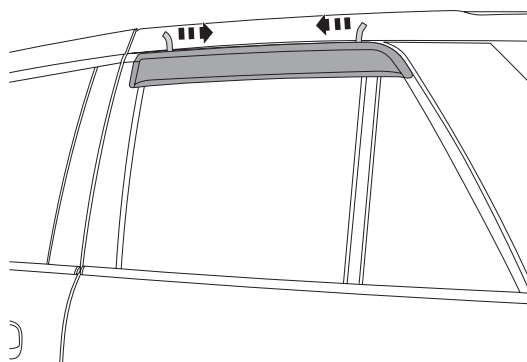

12

Repita los pasos 1 a 12 para el lado del acompañante

## Cuidado y limpieza

- Limpie solamente con agua jabonosa tibia y seque con un paño limpio.

## Felicidades

Usted ha comprado uno de los tantos artículos de calidad de Auto Ventshade™ ofrecidos por Lund International, Inc. Nuestros productos son nuestro mayor orgullo. Deseamos que disfrute de años de satisfacción con su inversión. Hemos realizado todos los esfuerzos para asegurarnos de que su producto sea de la mejor calidad en cuanto a ajuste, durabilidad, acabado y facilidad de instalación.



AUTO VENTSHADE™

Lund International, Ventshade Accessories Division

655 Raco Drive, Lawrenceville, GA 30045

800-241-7219 • Fax 770-339-5839 • Visite nuestro sitio Web: [lundinternational.com](http://lundinternational.com)



© 2005 Lund International, Inc. Todos los derechos reservados.  
Auto Ventshade™, el logo de Auto Ventshade™ y el logo de AVS™ son marcas comerciales de Lund International, Inc.

