



VDO Programmable Speedometer

Tech Support 1-800-265-1818
<http://usa.vdo.com>

Instruction Sheet # 0 515 012 051

Revision A

Parts list

<u>Item</u>	<u>Description</u>	<u>Quantity</u>
1.	Speedometer	1
2.	Lamp socket (push-in, wedge type)	2
3.	Light bulb (12v /G.E.. #158 or equivalent)	2
4.	VDO spin-lok™ Mounting Clamp	1
5.	Installation/Operating Instructions	1

1. General Information

The VDO Programmable Speedometer featured in this installation sheet is available in three diameters: 3 1/8" (80mm); 3 3/8" (85mm), and 4" (100mm).

VDO Programmable Speedometers can be used with *inductive, hall effect* sensors and signal wires from OE electronic control modules (ECM). If used with electronic transmissions the speedometer must be hooked up to the ECM. ***If wired directly to the transmission intermittent shifting may occur.***

CAUTION: Read these instructions thoroughly before installing the speedometer. Do not deviate from assembly or wiring instructions. Always disconnect the battery ground before making any electrical connections.

Technical Support 1-800-265-1818

2. Sensor Information

The proper sensor necessary to provide the correct signal to the speedometer is not included with this instrument and can be purchased separately from your auto parts distributor.

3. Mounting the Speedometer

Refer to the dimension chart on the next page for the proper mounting hole size for your speedometer.

Be careful to cut the correct size hole for the speedometer you have. Measure twice and cut once.





VDO Programmable Speedometer

Tech Support 1-800-265-1818
<http://usa.vdo.com>

Instruction Sheet # 0 515 012 051

Revision A

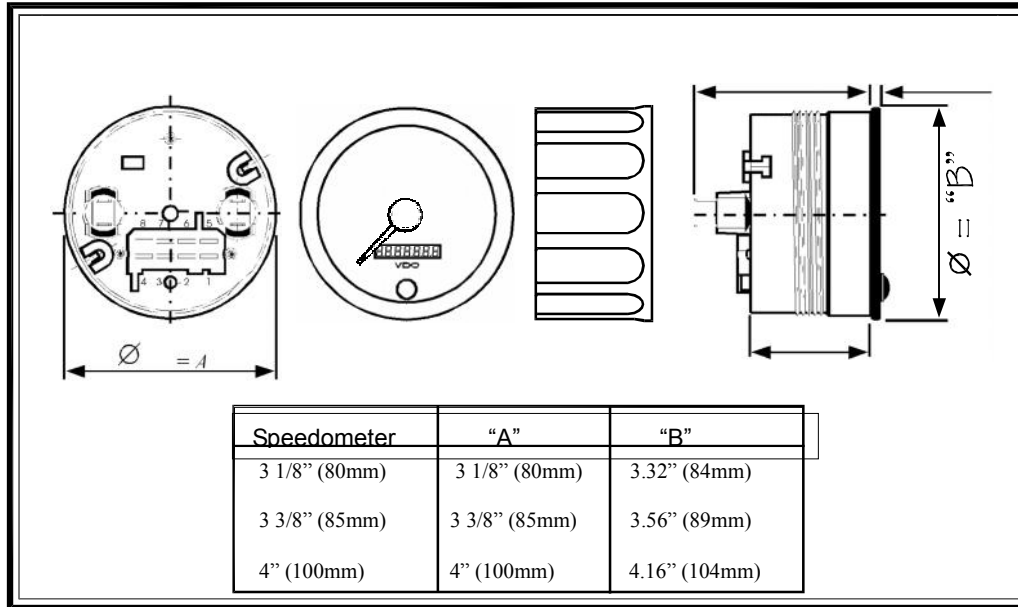
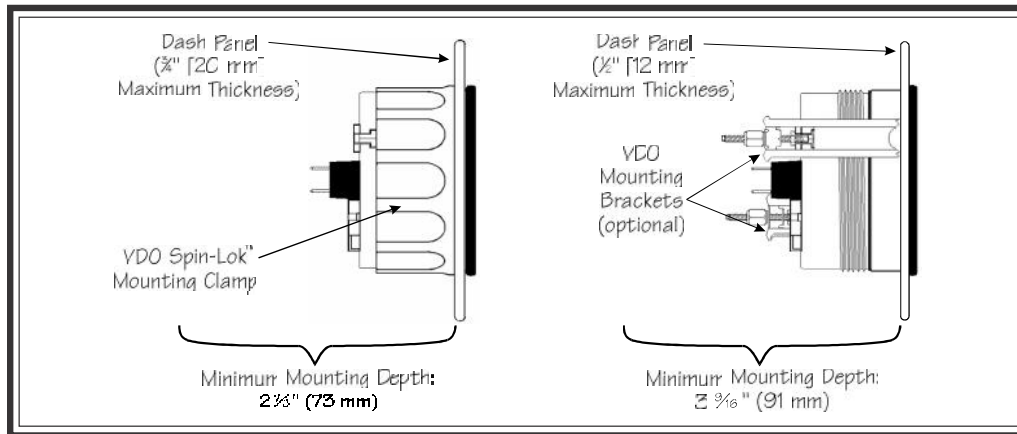

Diagram A – Programmable Speedometer dimensional guide



4. Wiring the Speedometer

DISCONNECT THE BATTERY BEFORE WIRING.

Refer to diagram B below for the sender wiring for a hall-effect (1); inductive (2) or engine control unit (3) type sender.

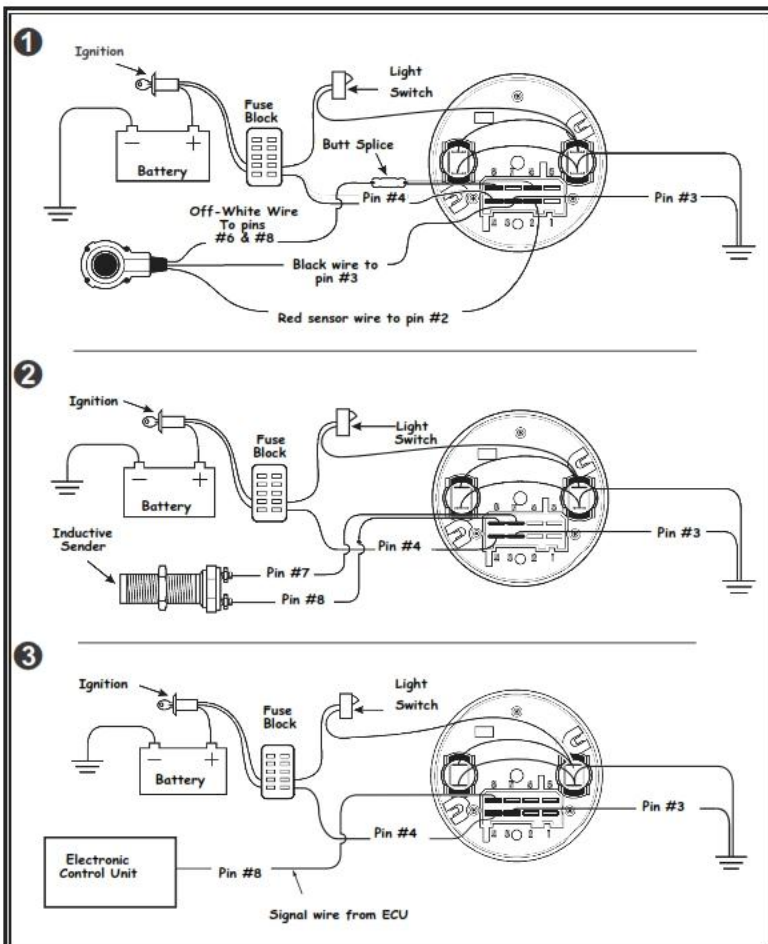

Pin Number

1. Not used
2. Red wire from Hall Effect sender
3. Ground and black wire from Hall Effect sender
4. 12V Switched
5. Not used
6. White wire (split) from Hall Effect sender
7. Not used
8. White wire (split) from Hall Effect sender

Pin Number

1. Not used
2. Not used
3. Ground
4. 12V Switched
5. Not used
6. Not used
7. Sender wire
8. Sender wire

Pin Number

1. Not used
2. Not used
3. Ground
4. 12V Switched
5. Not used
6. Not used
7. Not used
8. Sender wire

Diagram B

5. Connect lights to existing vehicle light circuit (in series if wiring more than one gauge.) 12V switched to one terminal of the light socket and ground to the other terminal.



VDO Programmable Speedometer

Tech Support 1-800-265-1818
http://usa.vdo.com

Instruction Sheet # 0 515 012 051

Revision A

6. Reconnect the battery and turn on ignition to ensure the gauge is working correctly.

When you turn on the ignition the speedometer will do an automatic self test. The needle will move across the entire scale and the LCD display will show the word "tEST". After the test is complete the display will show either the trip distance or the total distance depending on what was selected when the display was turned off. Since this is the first time, the display will show "0.0"

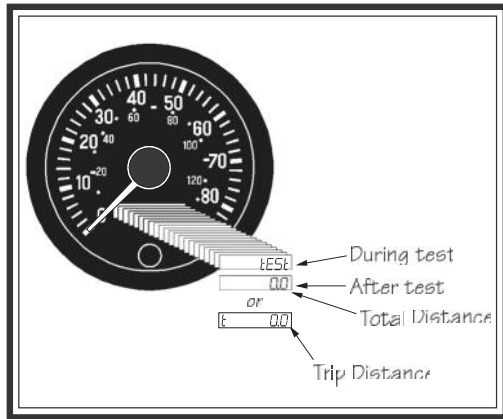

Diagram C

This self test will occur every time the ignition is turned on.

NOTE: THE 4 INCH VERSION OF THIS SPEEDOMETER DOES NOT HAVE THIS CIRCUIT AND WILL NOT DO A SELF TEST. ALL OTHER FUNCTIONS ARE THE SAME.

7. Calibrating the Speedometer

Calibrating the speedometer can be accomplished by one of three methods.

1. Automatic Calibration by driving on a road with an exact distance of one (1) mile clearly marked or on a dynamometer.
2. By the input of the known pulse-per-mile (kilometer) for the vehicle and sensor being used with the speedometer.
3. Using a reference point for adjustment of fine tuning.

The calibration mode is accessed by pressing the button below the LCD display and holding it BEFORE the ignition is turned on.

8. The LCD display will cycle through the three methods of calibration.

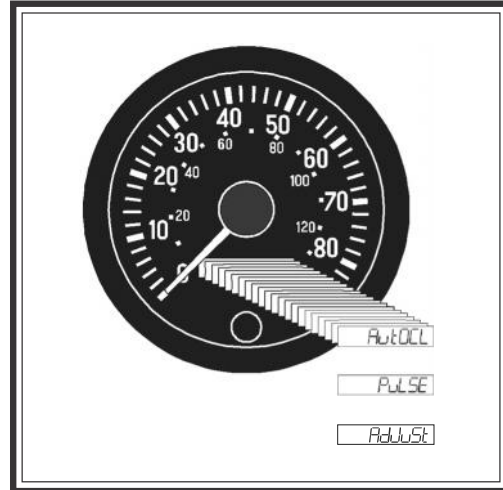

Diagram D

9. Autocalibration

a. Press and hold the button on the front of the speedometer and start the vehicle.

b. Release the button when "AutOCL" appears in the display. After a few seconds "bUtOn" will show in the display.

c. When you are ready to begin your mile run press the button once more and "StArt" will appear and you can begin driving one mile. Speed does not matter.

(Note: During the calibration run the needle will not move on the speedometer and "StArt" will flash. This is normal)

d. When you have driven exactly one mile press the button again. The microprocessor will then calculate the pulses received within its range limit of 500 to 399,999 and display that pulse count in the LCD display for a few seconds. The autocalibration will complete when the needle does a full sweep and returns to "0". However, if the speedometer does not see any pulses or a pulse range outside of its range the LCD will display "F - 0.0"

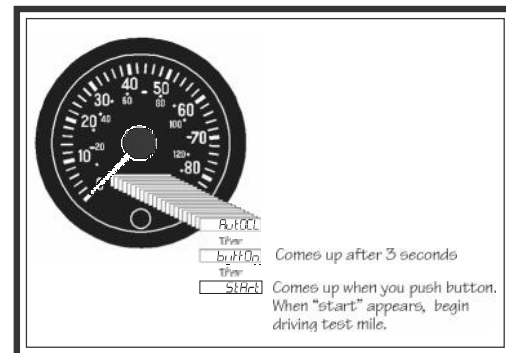

Diagram E

10. Manual Calibration with a known value

- Press and hold the button on the front of the speedometer and start the vehicle.
- Release the button when "PuLSE" appears in the LCD display.

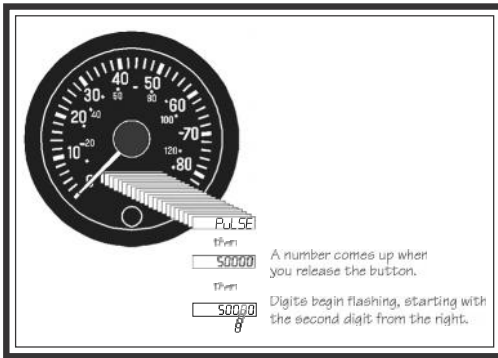

Diagram F

- After a few seconds the display will begin flashing a series of numbers. The last digit to the right is fixed at zero (0) and cannot be changed.
- As each number flashes from right to left you can change that value by pressing the button.
- As an example you can enter a pulse rate of 43850. When the first digit flashes press the button to enter a 5 (the last number is always zero and can't be changed) When the next digit flashes enter 8 then 3 then 4.
- With the display now reading 43850 allow the setting mode to time out. You will know this is complete when the needle does a full sweep of the dial and the LCD display shows "0.0"
- This method also allows you to manually adjust the pulses after an autocalibration has been done.

11. Manual Calibration (Fine Tuning)

You can manually adjust the analog pointer on your speedometer

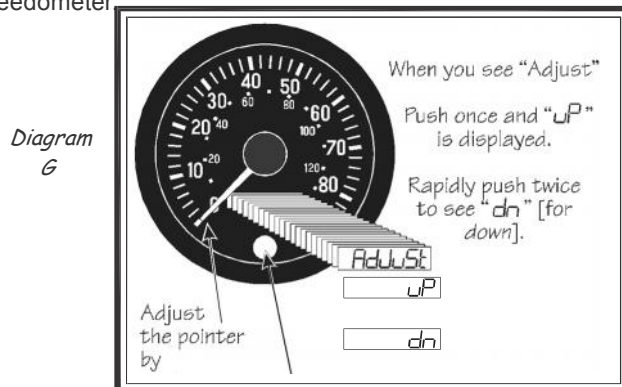

Diagram G

To manually calibrate the analog display with the vehicle on a dyno at a specified speed.

- Press and hold the button on the front of the speedometer and start the vehicle.
- Release the button when "AdJuSt" appears in the LCD display.
- Press the button once and "uP" will be displayed. Pressing the button twice in rapid succession will display "dn"
- When either "uP" or "dn" is displayed hold the button in and the pointer will move slowly in the direction selected. Holding the button longer will allow the pointer to move faster.
- When the pointer is adjusted to where you want it release the button and wait. If not adjustments are made within one minute the speedometer will revert to normal operation.

NOTE: If you have adjusted the pointer beyond its calibration range the display will flash and you will only be able to move the pointer in one direction back to the calibration range either up or down.

12. Speedometer Operation

- In normal operation the LCD will display total miles driven or trip distance.
- Pressing the button will toggle the display between these two displays.
- Pressing and holding the button will reset the trip distance regardless of which distance is currently displayed.

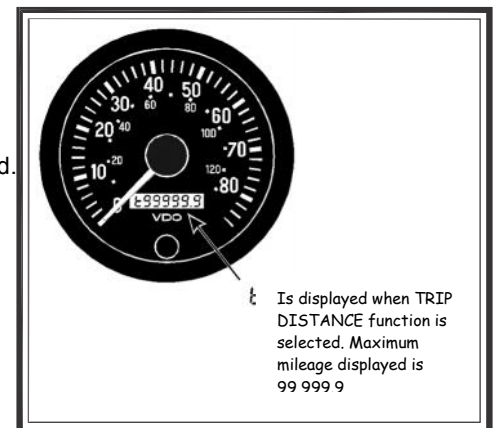

Diagram H

Merchandise warranted against defects in factory workmanship and materials for a period of 24 months after purchase. This warranty applies to the first retail purchaser and covers only those products exposed to normal use or service. Provisions of this warranty shall not apply to a VDO product used for a purpose for which it is not designed, or which has been altered in any way that would be detrimental to the performance or life of the products, or misapplication, misuse, negligence or accident. On any VDO part or VDO product found to be defective after examination by manufacturer, manufacturer will only repair or replace the merchandise through the original selling dealer. Manufacturer assumes no responsibility for diagnosis, removal and/or installation labor, loss of vehicle use, loss of time, inconvenience or any other consequential expenses. The warranties herein are in lieu of any other expressed or implied warranties, including any implied warranty or merchantability of fitness, and any other obligation on the part of manufacturer, or selling dealer.

52mm

Conventional (Included)

Instrument is put into the drilled hole from the front. The maximum panel thickness is 20mm. The drilled hole must have a diameter of 53mm.

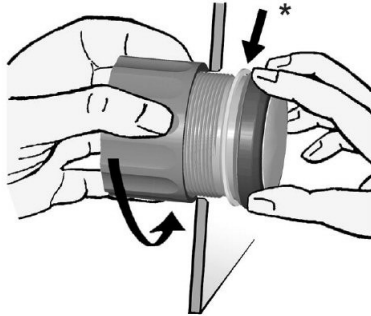

* Make sure the seal lays flat between the panel and the front ring.

For 52mm instruments, the Spin-Lok™ nut can be mounted at position A or B. This allows you two clamping depths.

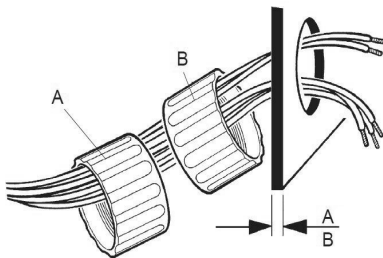

Version A
10mm

Version B
20mm

Flush (Optional)

When flush mounting (i. e., from the back so that the instrument glass and the panel form one plane), the front ring must be removed. Press on the instrument glass with both thumbs, while at the same time pulling the front ring forward from the instrument with both index fingers.

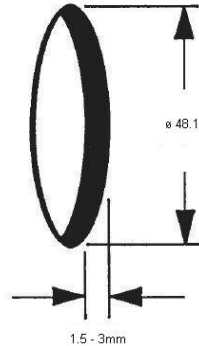

The recommended panel thickness is 1.5 to 3 mm. The drill hole must have a diameter of 48.1mm. Ensure that the installation location is level and has no sharp edges.

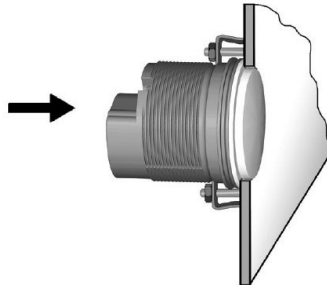

Place the flush mount seal on the instrument glass. Put the instrument into the drill hole from the back. Adjust the instrument so that the gauge is level and fasten it to the stud bolts (not included) on the rear side of the panel, using the flush mount fixing brackets.

Stud (Optional)

If you would like to omit the fastening nut, you may use the stud mount as an alternative. This is recommended if the installation location is subject to extreme vibrations.

Screw the stud bolts into the drilled holes on the rear of the instrument housing. Max. stud bolt torque is 1.5Nm.

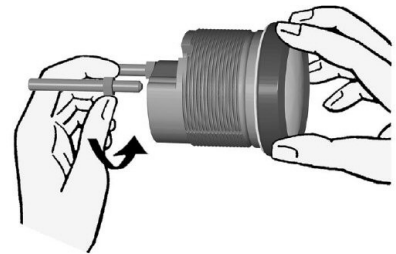

Place the bracket on the stud bolt and tighten the knurled nut. Do not over-tighten.

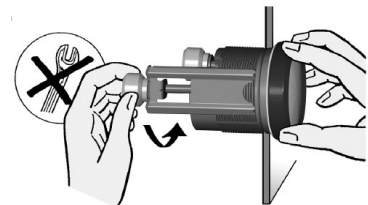

* Make sure the seal lays flat between the panel and the front ring.