

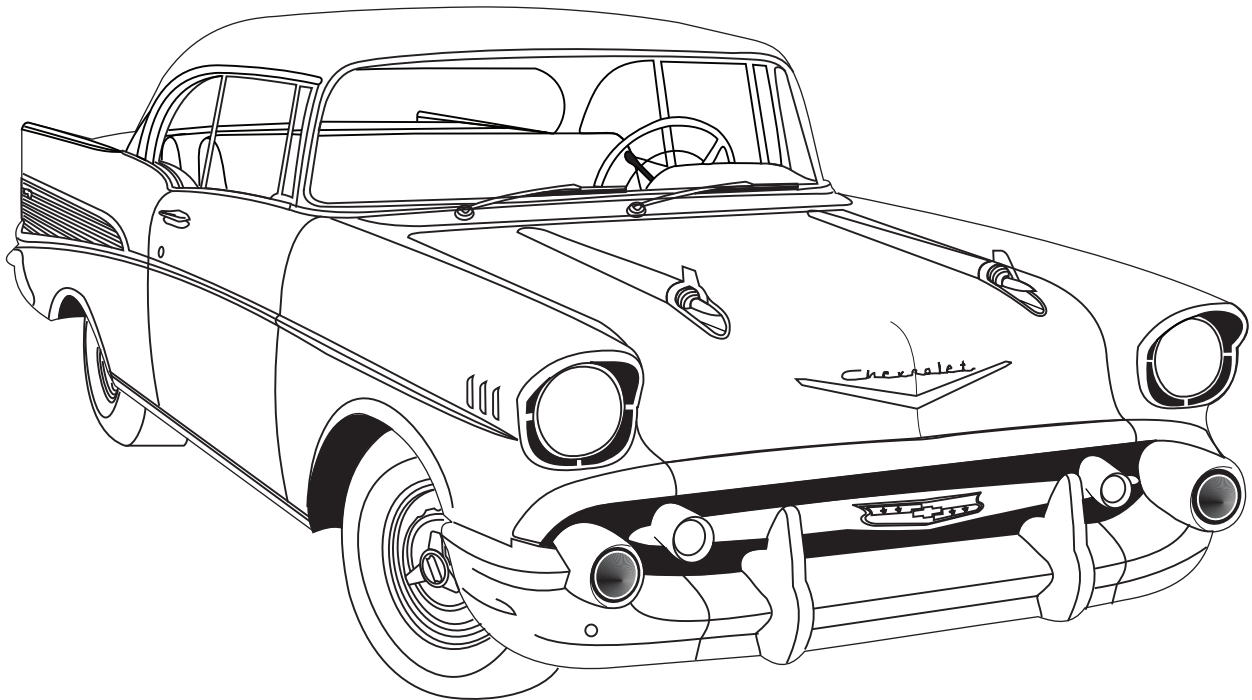

an ISO 9001:2008 Registered Company

# 1957 Chevrolet Full-Size

*with 6-Cylinder Position  
Condenser Kit with Drier  
(025702)*



18865 Goll St. San Antonio, TX 78266  
Phone: 800-862-6658  
Sales: [sales@vintageair.com](mailto:sales@vintageair.com)  
Tech Support: [tech@vintageair.com](mailto:tech@vintageair.com)  
[www.vintageair.com](http://www.vintageair.com)



[www.vintageair.com](http://www.vintageair.com)

# Table of Contents

Cover.....	1
Table of Contents.....	2
Packing List/Parts Disclaimer.....	3
Important Notice.....	4
Core Support Measurements.....	5
Engine Compartment Disassembly.....	6
Condenser Mounting Bracket Installation.....	7
Core Support Panel Modification.....	8
Drier & Drier Bracket Installation.....	9
Hardline & Binary Switch Installation.....	10
Hardline & Binary Switch Installation (Cont.), Lubricating O-rings, Final Steps.....	11
Packing List.....	12



www.vintageair.com

## Packing List: Condenser Kit (025702)

No.	Qty.	Part No.	Description
1.	1	037036	Condenser, 17" x 19", Parallel Flow
2.	1	07321-VUC	Drier
3.	1	23135-VUW	Compressor Lead
4.	1	11079-VUS	Binary Switch, Male
5.	1	646904	Bracket, Drier
6.	1	646800	Bracket, Condenser, Passenger Side
7.	1	646801	Bracket, Condenser, Driver Side
8.	1	091616	Hardline, #6 Condenser/Drier
9.	1	091617	Hardline, #8 Condenser/Compressor
10.	2	180881	Stud, 5/16-18 x 1"
11.	1	18125-VUB	Washer, 1/4", Flat
12.	1	18152-VUB	Nut with Star Washer, 1/4-20
13.	8	18249-VUB	Screw, 10-24 x 3/8"
14.	8	18260-VUB	Nut with Star Washer, 10-24
15.	1	33134-VUI	Grommet, 2-Hole
16.	2	33857-VUF	O-ring, #6
17.	1	33858-VUF	O-ring, #8

**\*\* Before beginning installation, open all packages and check contents of shipment. Please report any shortages directly to Vintage Air within 15 days. After 15 days, Vintage Air will not be responsible for missing or damaged items.**

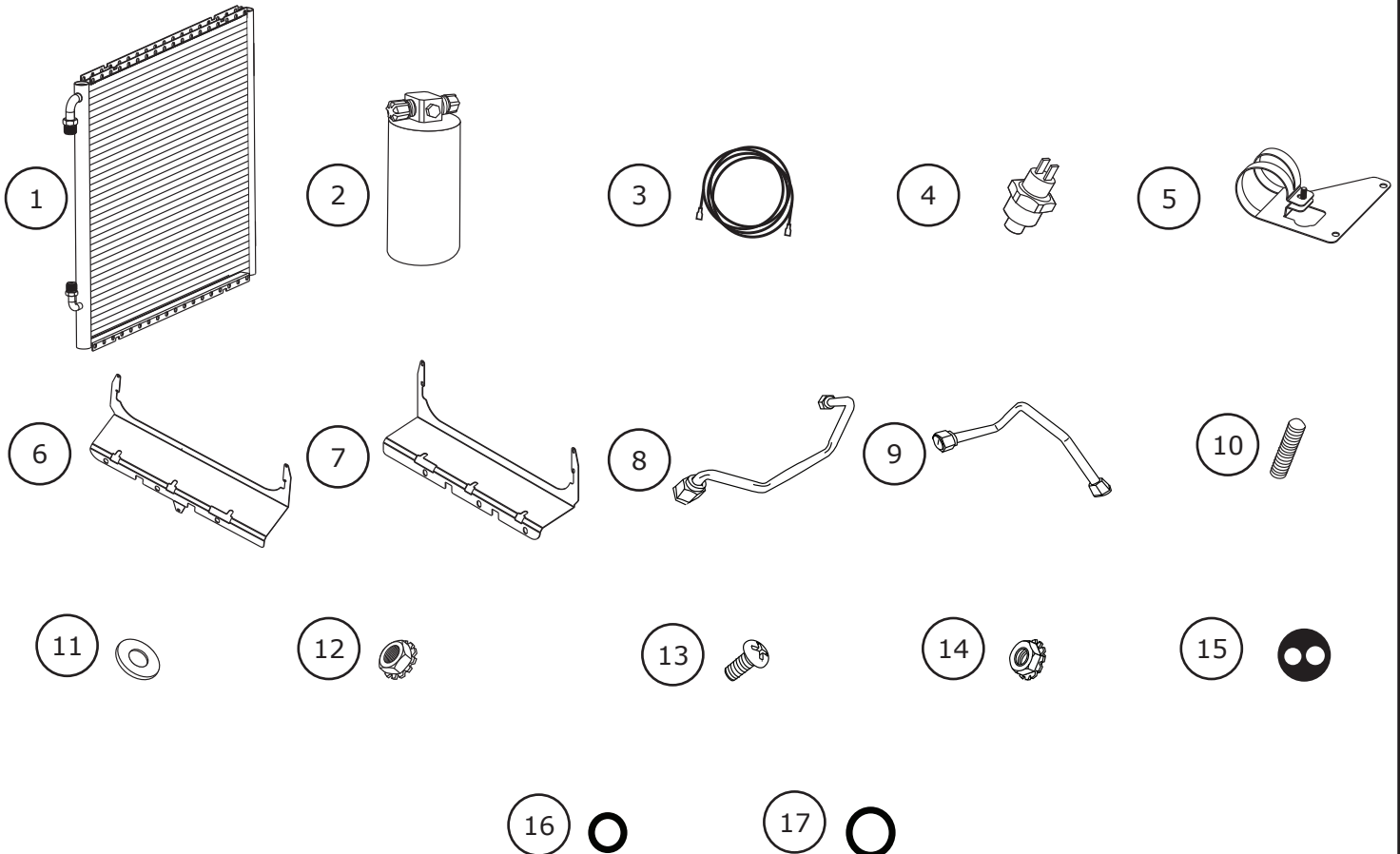

**NOTE: Images may not depict actual parts and quantities. Refer to packing list for actual parts and quantities.**



www.vintageair.com

## Important Notice—Please Read

*For Maximum System Performance, Vintage Air Recommends the Following:*

**NOTE:** Vintage Air systems are designed to operate with R134a refrigerant only. Use of any other refrigerant could damage your A/C system and/or vehicle, and possibly cause a fire, in addition to potentially voiding the warranties of the A/C system and its components.

### Refrigerant Capacities:

**Vintage Air System:** 1.8 lbs. (1 lb., 12 oz.) of R134a, charged by weight with a quality charging station or scale. **NOTE:** Use of the proper type and amount of refrigerant is critical to system operation and performance.

**Other Systems:** Consult manufacturer's guidelines.

### Lubricant Capacities:

**New Vintage Air-supplied Sanden Compressor:** No additional oil needed (Compressor is shipped with proper oil charge).

**All Other Compressors:** Consult manufacturer (Some compressors are shipped dry and will need oil added).

### Safety Switches

Your Vintage Air system is equipped with a binary pressure safety switch. A binary switch disengages the compressor clutch in cases of extreme low pressure conditions (Refrigerant Loss) or excessively high head pressure (406 PSI) to prevent compressor damage or hose rupture. A trinary switch combines Hi/Lo pressure protection with an electric fan operation signal at 254 PSI, and should be substituted for use with electric fans. Compressor safety switches are extremely important since an A/C system relies on refrigerant to circulate lubricant.

### Service Info:

**Protect Your Investment:** Prior to assembly, it is critical that the compressor, evaporator, A/C hoses and fittings, hardlines, condenser and receiver/drier remained capped. Removing caps prior to assembly will allow moisture, insects and debris into the components, possibly leading to reduced performance and/or premature failure of your A/C system. This is especially important with the receiver/drier.

Additionally, when caps are removed for assembly, **BE CAREFUL!** Some components are shipped under pressure with dry nitrogen.

**Evacuate the System for 35-45 Minutes:** Ensure that system components (Drier, compressor, evaporator and condenser) are at a temperature of at least 85° F. On a cool day, the components can be heated with a heat gun **or** by running the engine with the heater on before evacuating. Leak check and charge to specifications.

### Bolts Passing Through Cowl and/or Firewall:

To ensure a watertight seal between the passenger compartment and the vehicle exterior, for all bolts passing through the cowl and/or firewall, Vintage Air recommends coating the threads with silicone prior to installation.

### Heater Hose (Not Included With This Kit):

Heater hose may be purchased from Vintage Air (Part# 31800-VUD) or your local parts retailer. Routing and required length will vary based on installer preference.



www.vintageair.com

## Core Support Measurements

This kit was developed based on the measurements below, which were taken from a 1957 Chevrolet Bel Air 6-Cylinder.

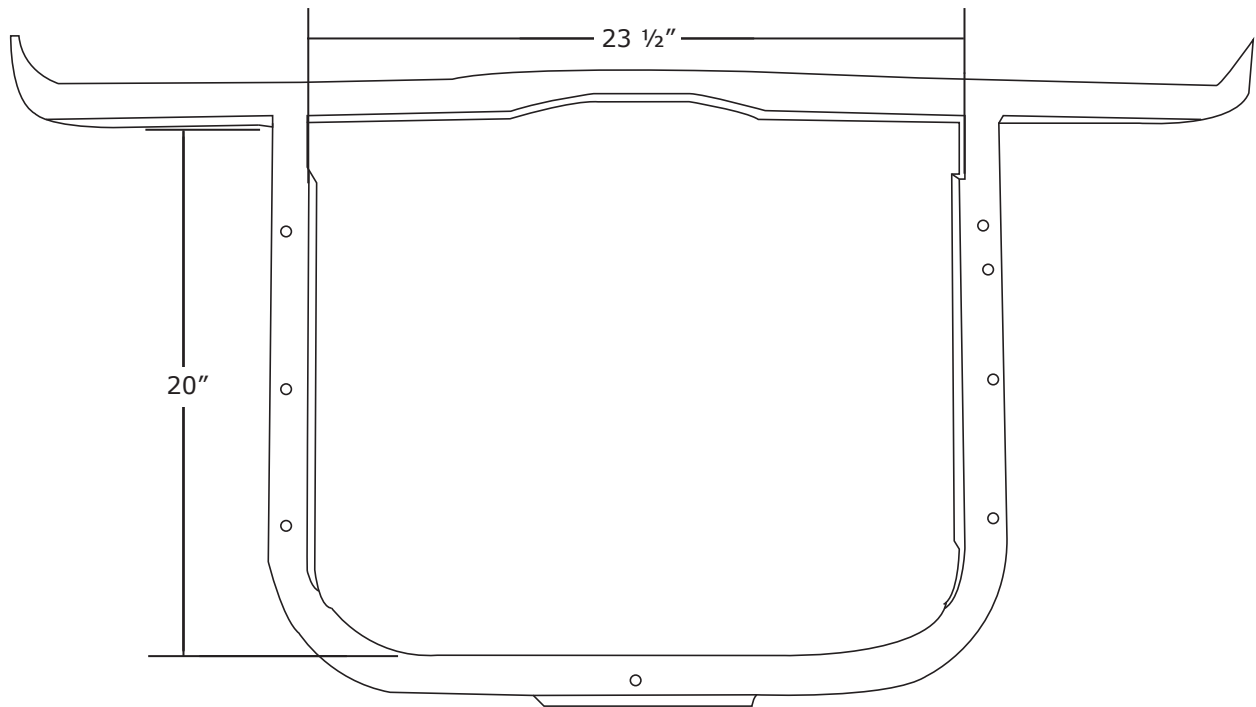



www.vintageair.com

## Engine Compartment Disassembly

**NOTE:** Before starting the installation, check the function of the vehicle (horn, lights, etc.) for proper operation, and study the instructions, illustrations, & diagrams. Some photos are from a 1957 Chevrolet Bel Air V8 and are shown for representation purposes only.

### Perform the Following:

1. Disconnect the battery.
2. Remove the battery (retain).
3. Remove the battery tray by removing (2) bolts from the core support and (2) bolts from under the inner fender (retain) (See Photos 1 & 2, below).
4. Remove the driver side horn by removing the bolt securing the horn to the core support (retain) (See Photo 3, below).
5. Remove the passenger side horn and loosen the passenger side core support panel by removing (1) bolt under the splash apron, and (5) bolts from the front of the panel. **NOTE: The core support panel and radiator do not need to be removed. The condenser assembly will install on the front of the radiator and core support.**

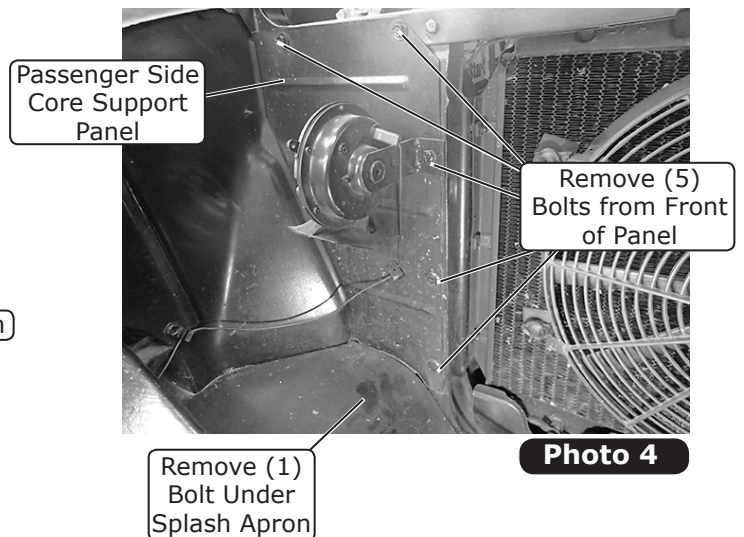
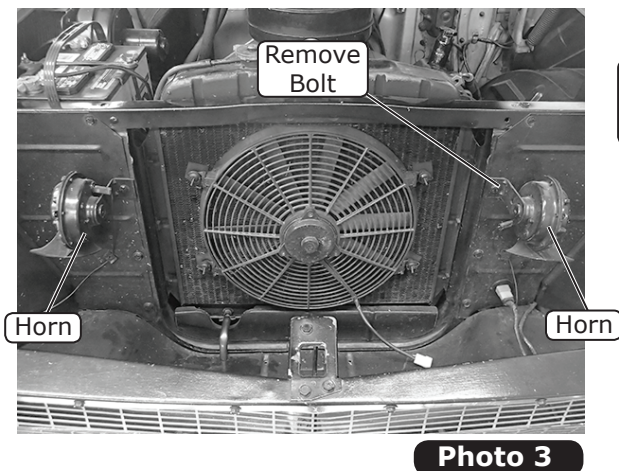
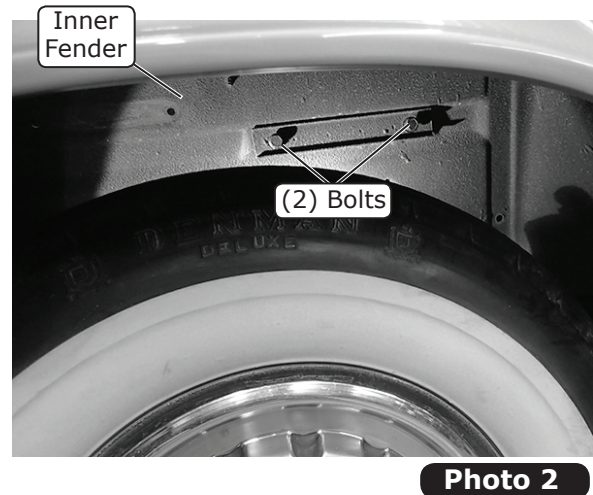
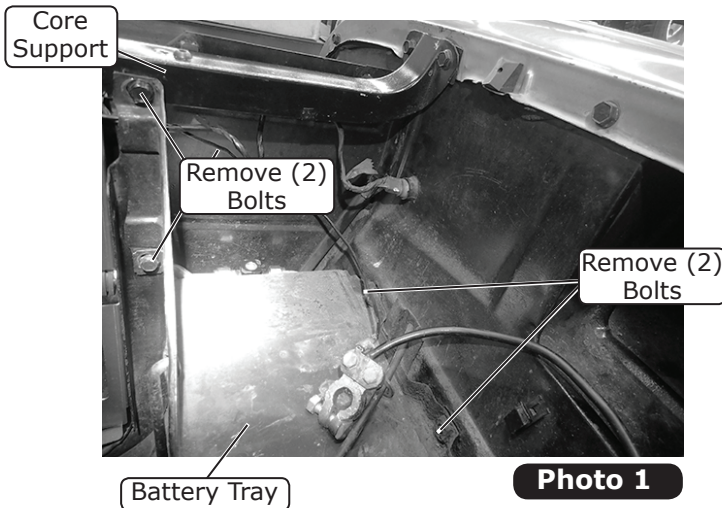



www.vintageair.com

## Condenser Mounting Bracket Installation

1. On a workbench, place the condenser front side down, and install the passenger side condenser bracket onto the upper and lower rear flanges of the condenser using (4) 10-24 x 3/8" screws and (4) 10-24 nuts with star washers as shown in Photo 1, below. **NOTE: The bracket mounts to the 1st & 3rd holes on the condenser flange (See Photo 2, below). Do not break off the tab on the passenger side condenser bracket. It will be used as a drill template.**
2. Install the driver side condenser bracket onto the upper and lower rear flanges on the condenser using (4) 10-24 x 3/8" screws and (4) 10-24 nuts with star washers as shown in Photo 3, below. **NOTE: The bracket mounts to the 1st & 3rd holes on the condenser flange (See Photo 3, below).**

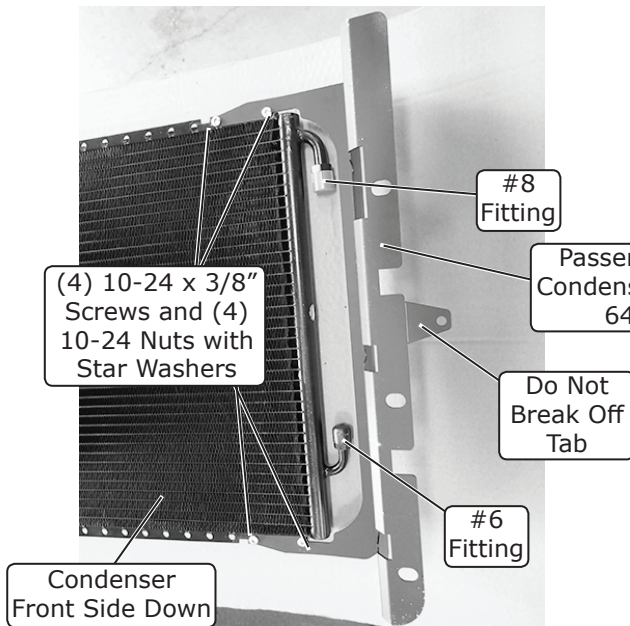

Rear View

Photo 1

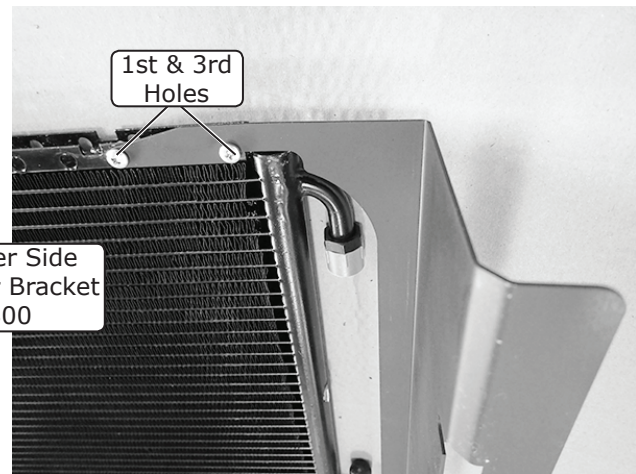

Rear View

Photo 2

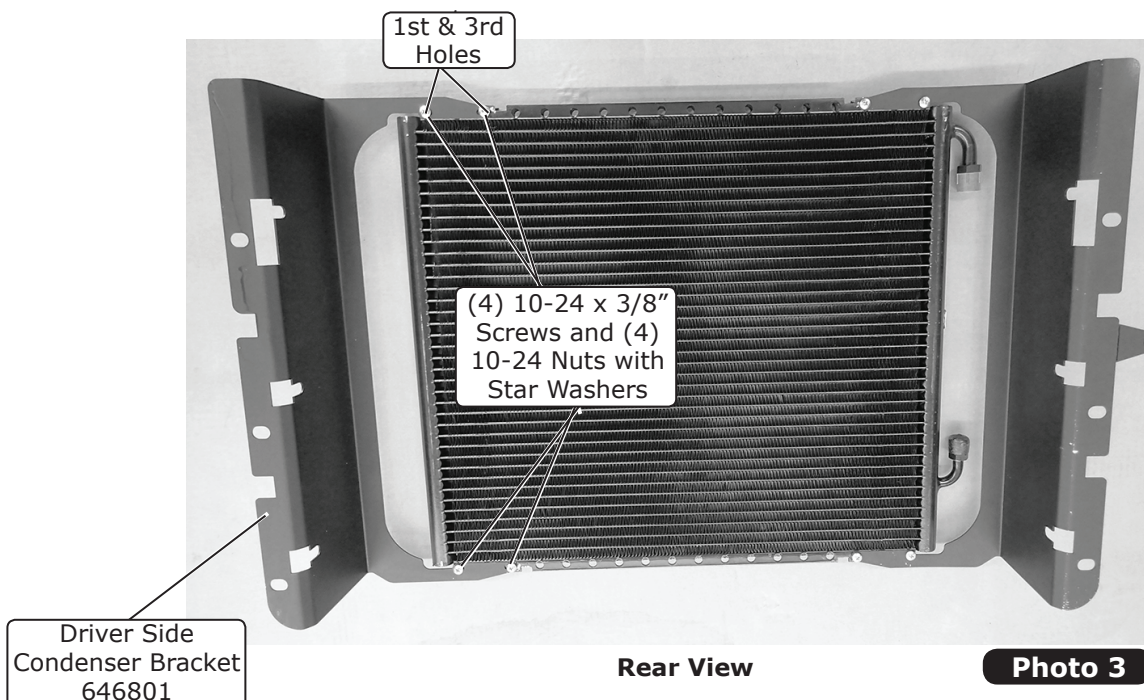

Rear View

Photo 3



www.vintageair.com

## Core Support Panel Modification

1. Remove the center bolts from each side of the radiator. Install a 5/16-18" x 1" stud in the center bolt hole on each side of the core support. Remove the (4) remaining bolts securing the radiator to the core support ((2) on each side of the radiator) (See Photo 1, below).
2. Install the condenser assembly onto the front of the radiator and core support while pulling slightly outward on the condenser brackets to clear the studs. Loosely install (4) OEM bolts into the upper and lower radiator holes ((2) on each side of the radiator) (See Photo 2, below).
3. Install (4) OEM bolts through the condenser brackets, through the side panels and into the core support. Install (3) bolts on the driver side of the core support and (1) bolt into the top hole on the passenger side (See Photos 3 & 4, below). Align and adjust the radiator as needed, and tighten the bolts at this time.
4. Locate the passenger side condenser bracket tab with a 1/4" hole (See Photo 5, below). Mark and drill the 1/4" hole into the passenger side core support panel (See Photo 5, below).
5. Break off the tab, and enlarge the previously drilled 1/4" hole to 1 1/4" using a step drill or hole saw (See Photo 6, below).
6. Clean and deburr the 1 1/4" hole (See Photo 6, below).

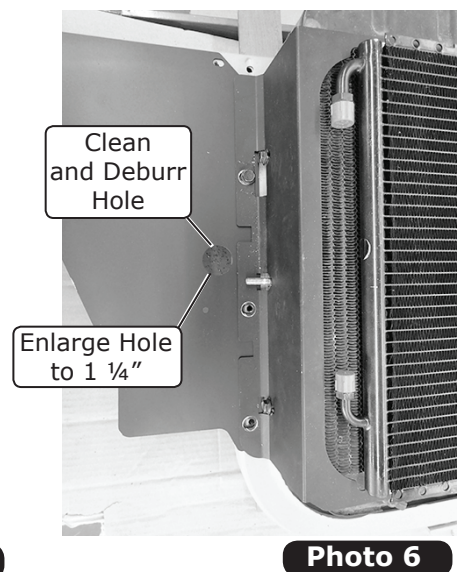
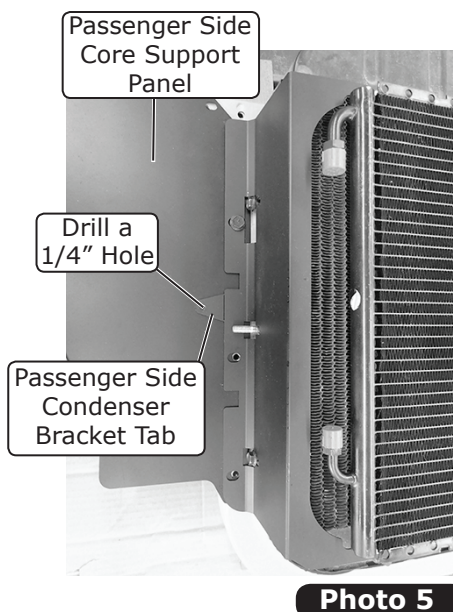
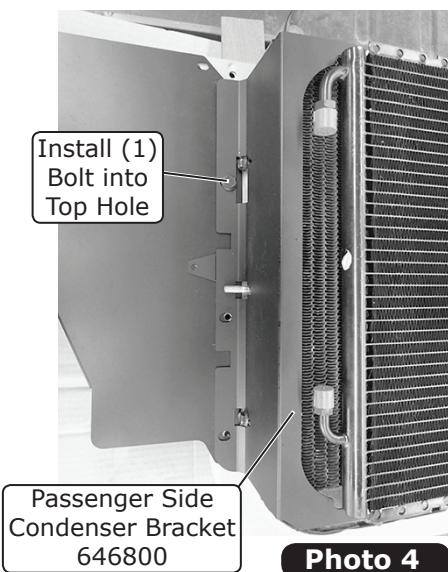
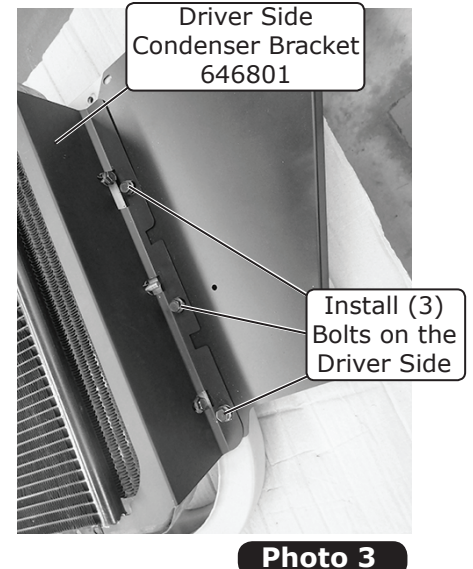
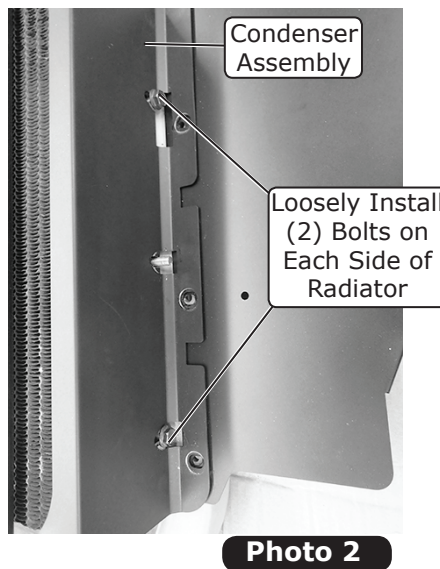
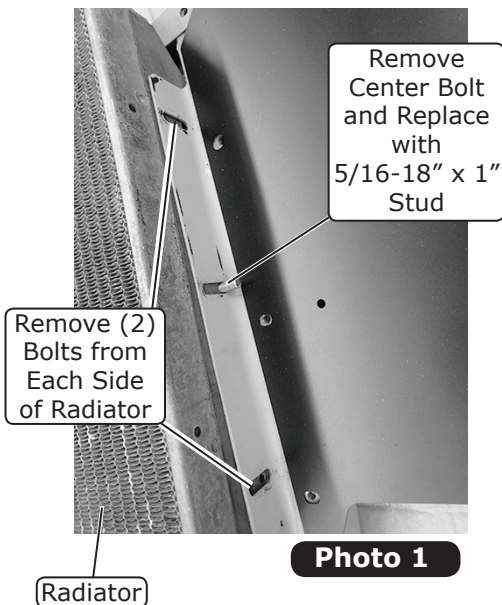





www.vintageair.com

# Drier & Drier Bracket Installation

**NOTE: Do not remove the caps from the drier. The drier contains a desiccant that will quickly absorb moisture from the air, causing it to lose effectiveness. For this reason, Vintage Air recommends that the drier remains capped until the installer is ready to evacuate the system.**

**Perform the Following:**

1. Insert the drier into the drier bracket, and secure it using a 1/4" flat washer and a 1/4-20 nut with star washer (See Photo 1, below). **NOTE: Do not fully tighten the nut at this time.**
2. From the engine side, install the drier assembly onto the passenger side of the core support (See Photo 2, below). Slide the drier assembly in between the core support and the passenger side core support panel. Align the (2) drier bracket holes with the (2) lower core support bracket mounting holes. From the front of the core support, install (2) OEM bolts through the passenger side condenser bracket, through the passenger side core support panel, through the drier bracket, and into the core support (See Figure 1, below).
3. Adjust the drier in the clamp so that it does not sit on the bottom of the apron. Leave a gap between the bottom of the drier and the apron (approximately 3/16"), and tighten the nut on the drier clamp just enough to keep the drier in place (See Figure 2, below). **NOTE: Do not fully tighten the drier nut at this time. Final adjustment of the drier is done after the #6 condenser/drier hardline is installed.**

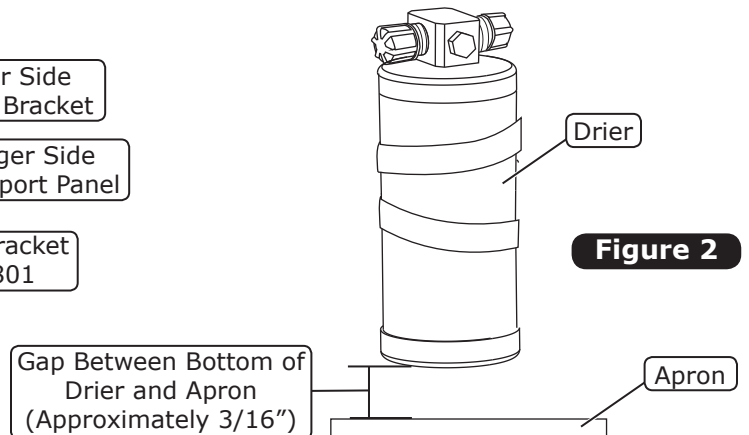
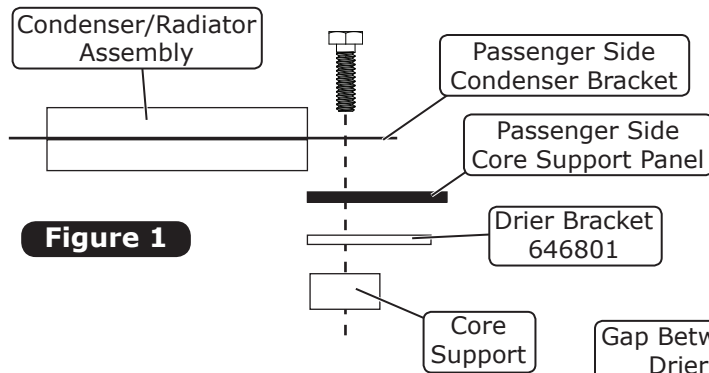
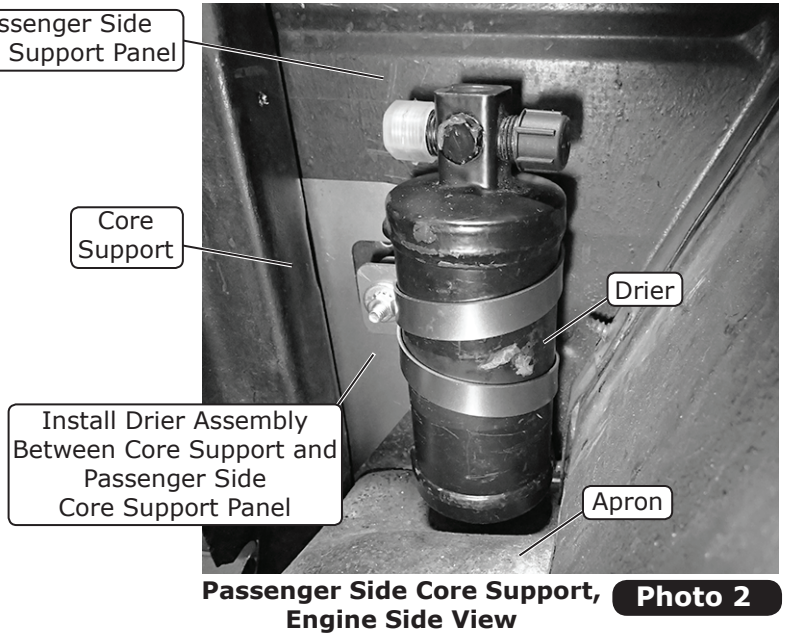
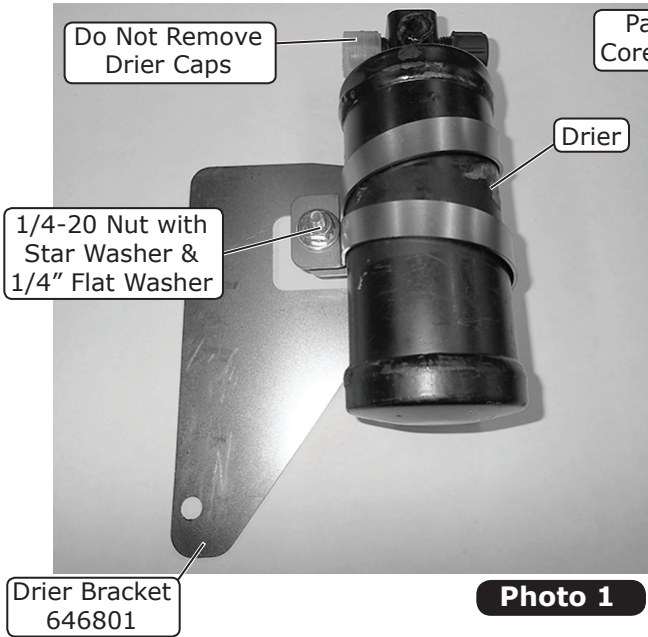



www.vintageair.com

## Hardline & Binary Switch Installation

1. Locate the #6 condenser/drier hardline, and route the short end of the hardline through the 1 ¼" hole in the passenger side core support panel as shown in Photo 1, below.
2. Locate the #8 condenser/compressor hardline, and route the male end of the hardline through the 1 ¼" hole in the core support panel next to the #6 condenser/drier hardline as shown in Photo 2, below.
3. Using a properly lubricated #6 O-ring, connect the female fitting on the short end of the #6 condenser/drier hardline to the IN fitting on the drier. (See Photo 3, below, and Figure 3, Page 11).
4. Using a properly lubricated #6 O-ring, connect the female fitting on the long end of the #6 condenser/drier hardline to the #6 fitting on the condenser (See Photo 4, below, and Figure 3, Page 11). Raise, lower, or clock the drier as needed to attain a suitable fit (See Photo 4, below), and tighten the nut on the drier clamp. Tighten both ends of the #6 condenser/drier hardline at this time (See Figure 3, Page 11). **NOTE: Refrigerant flow through the drier is IN from condenser, OUT to evaporator.**
5. Using a properly lubricated #8 O-ring, connect the female fitting on the #8 condenser/compressor hardline to the #8 fitting on the condenser (See Photo 5, below, and Figure 3, Page 11). **NOTE: The male end of the #8 condenser/compressor hardline will connect to the #8 condenser/compressor A/C hose.**

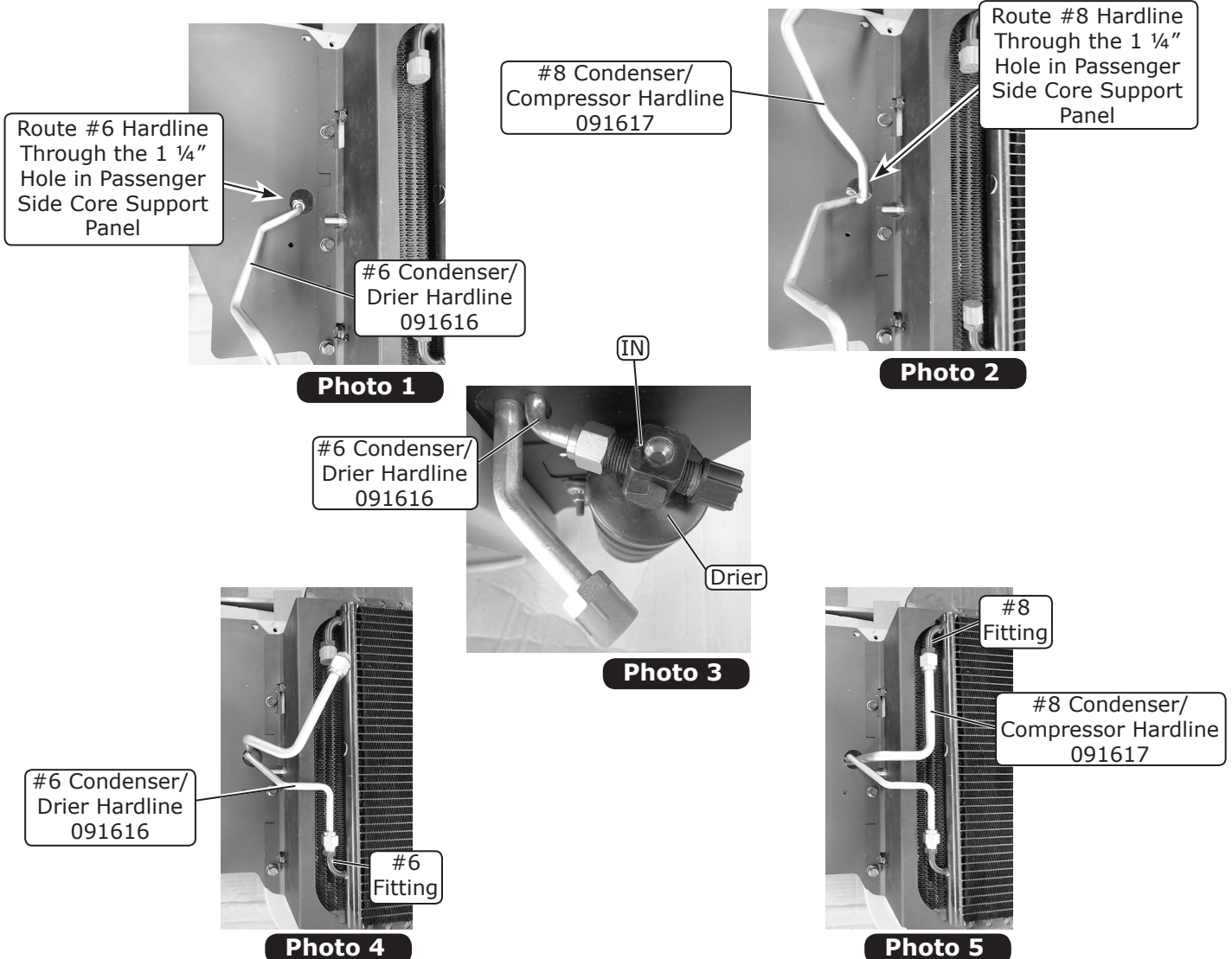



www.vintageair.com

## Hardline & Binary Switch Installation (Cont.)

6. Locate the 2-hole grommet, and install it into the 1 1/4" hole in the passenger side core support panel (See Photo 6, below).
7. Install the male binary switch onto the drier using a properly lubricated O-ring (See Photo 7, below). **NOTE: The binary switch and the drier each come with an O-ring for the binary switch. Only (1) O-ring will be used.**

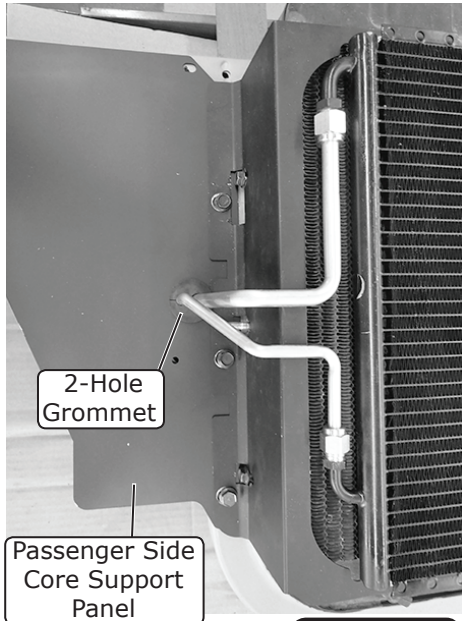

Photo 6

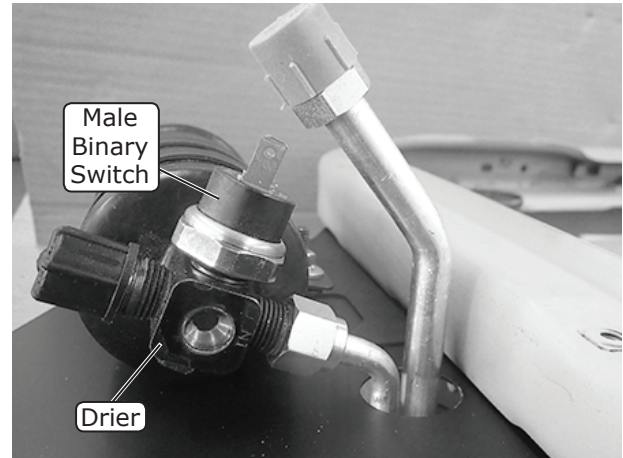
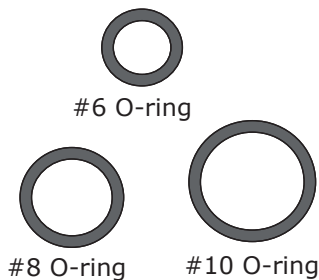
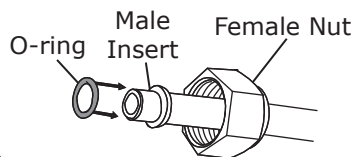

Photo 7

## Lubricating O-rings



**NOTE: Standard torque specifications:**  
**#6: 11 to 13 ft-lb.**  
**#8: 15 to 20 ft-lb.**  
**#10: 21 to 27 ft-lb.**



**For a proper seal of fittings: Install supplied O-rings as shown, and lubricate with supplied oil.**

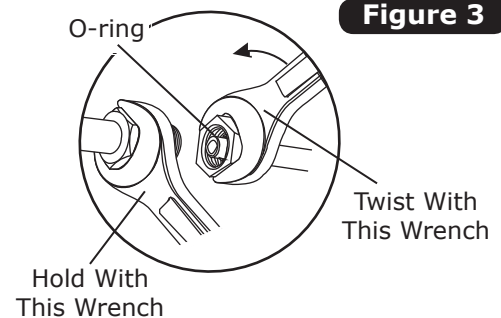
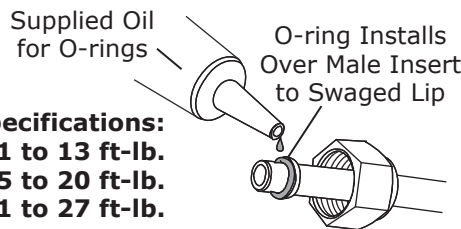

Figure 3

## Final Steps

1. Reinstall the remaining bolt on the passenger side core support panel, and verify that all bolts and hardlines are tight.
2. Reinstall the battery tray using the OEM bolts.
3. Reinstall the passenger and driver side horns in their original locations using the OEM bolts.
4. Remove the (2) studs securing the radiator, and replace them with (2) OEM bolts.
5. Reinstall and/or reconnect all remaining items removed or disconnected in the Engine Compartment Disassembly instructions on Page 6. This concludes the condenser kit portion of your installation.



www.vintageair.com

## Packing List: Condenser Kit (025702)

No.	Qty.	Part No.	Description
1.	1	037036	Condenser, 17" x 19", Parallel Flow
2.	1	07321-VUC	Drier
3.	1	23135-VUW	Compressor Lead
4.	1	11079-VUS	Binary Switch, Male
5.	1	646904	Bracket, Drier
6.	1	646800	Bracket, Condenser, Passenger Side
7.	1	646801	Bracket, Condenser, Driver Side
8.	1	091616	Hardline, #6 Condenser/Drier
9.	1	091617	Hardline, #8 Condenser/Compressor
10.	2	180881	Stud, 5/16-18 x 1"
11.	1	18125-VUB	Washer, 1/4", Flat
12.	1	18152-VUB	Nut with Star Washer, 1/4-20
13.	8	18249-VUB	Screw, 10-24 x 3/8"
14.	8	18260-VUB	Nut with Star Washer, 10-24
15.	1	33134-VUI	Grommet, 2-Hole
16.	2	33857-VUF	O-ring, #6
17.	1	33858-VUF	O-ring, #8

Checked By: \_\_\_\_\_  
 Packed By: \_\_\_\_\_  
 Date: \_\_\_\_\_

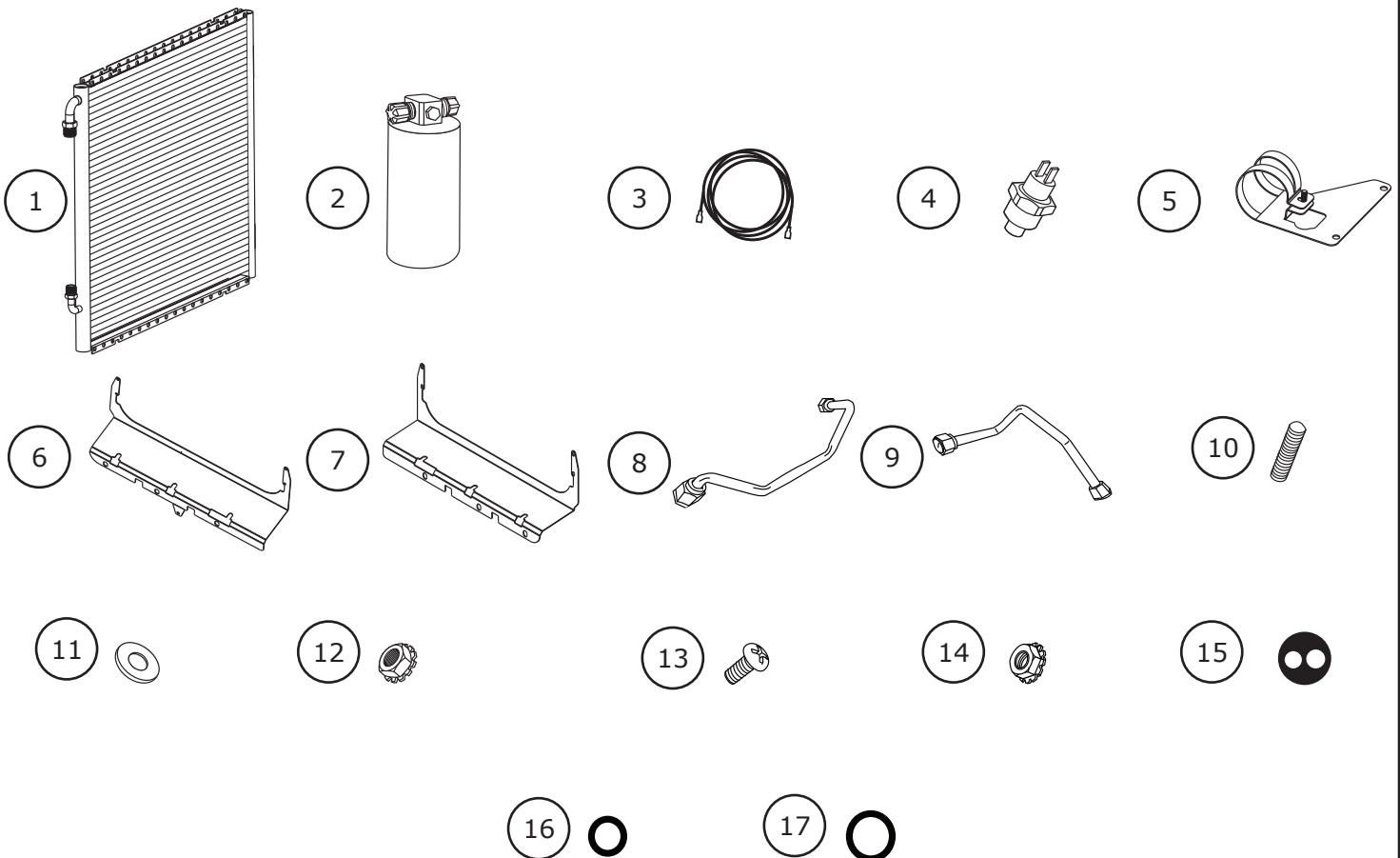

**NOTE: Images may not depict actual parts and quantities.  
 Refer to packing list for actual parts and quantities.**