



an ISO 9001:2015 Registered Company

Streamline Heater

(660066)



18865 Goll St. San Antonio, TX 78266
Phone: 800-862-6658
Sales: sales@vintageair.com
Tech Support: tech@vintageair.com
www.vintageair.com



www.vintageair.com

Table of Contents

Cover.....	1
Table of Contents.....	2
Packing List/Parts Disclaimer.....	3
Heater Unit Installation.....	4
Heater Unit Installation (Cont.).....	5
Heater Hose and Heater Control Valve Installation.....	6
Wiring Installation.....	7
Wiring Diagram.....	8
Final Steps, Control Panel Operation.....	9
Packing List.....	10



www.vintageair.com

Packing List: Heater Kit (660066)

No.	Qty.	Part No.	Description
1.	1	660065	Streamline Heater
2.	1	231089	Wiring and Hardware Kit

**** Before beginning installation, open all packages and check contents of shipment. Please report any shortages directly to Vintage Air within 15 days. After 15 days, Vintage Air will not be responsible for missing or damaged items.**

1



2

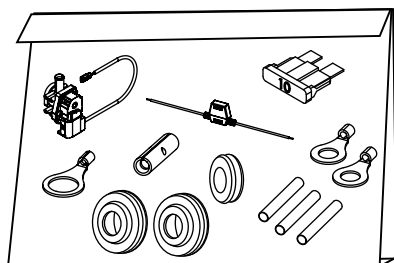

**NOTE: Images may not depict actual parts and quantities.
Refer to packing list for actual parts and quantities.**



www.vintageair.com

Heater Unit Installation

1. Remove the (4) 1/4 x 1/2" button head screws from the rear-mounting bracket (See Figure 1, below).
2. Place the heater in the desired position on the firewall and using the rear bracket as a template mark the (4) holes in the firewall, then remove the heater and drill (4) 1/4" holes.
3. Temporarily, install the heater unit on firewall using the previously removed 1/4 x 1/2" button head screws (See Figure 2, below).

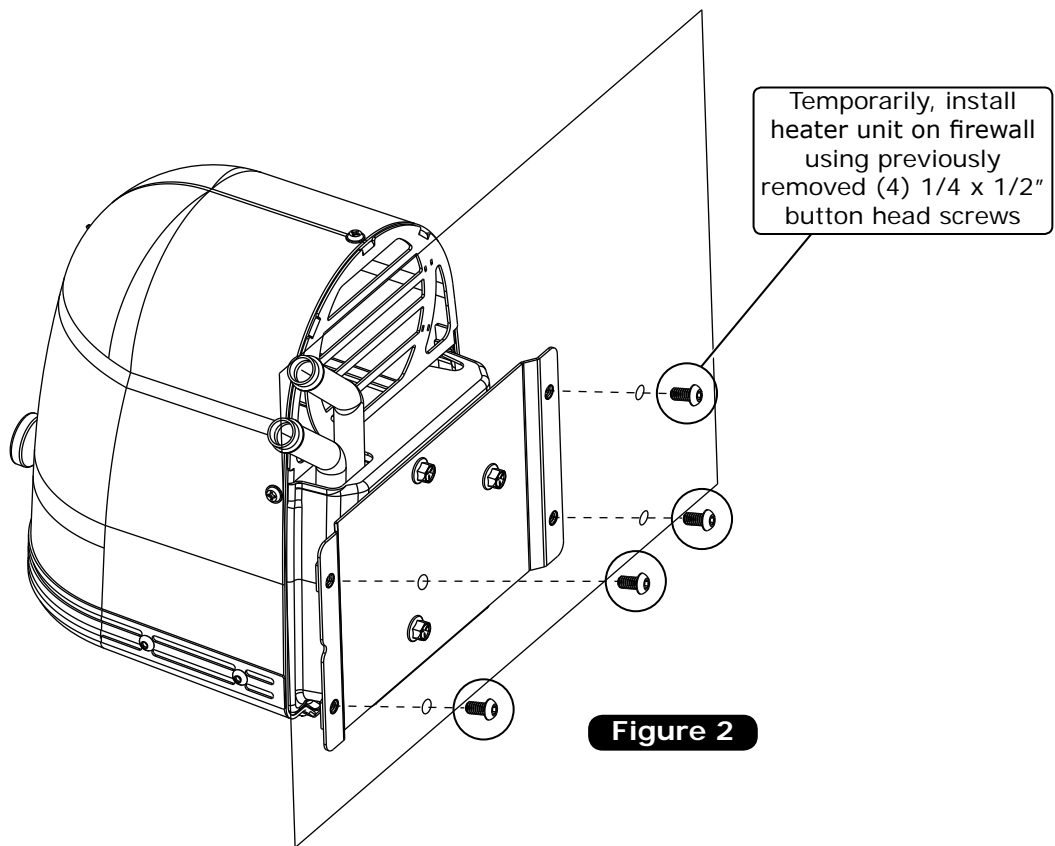
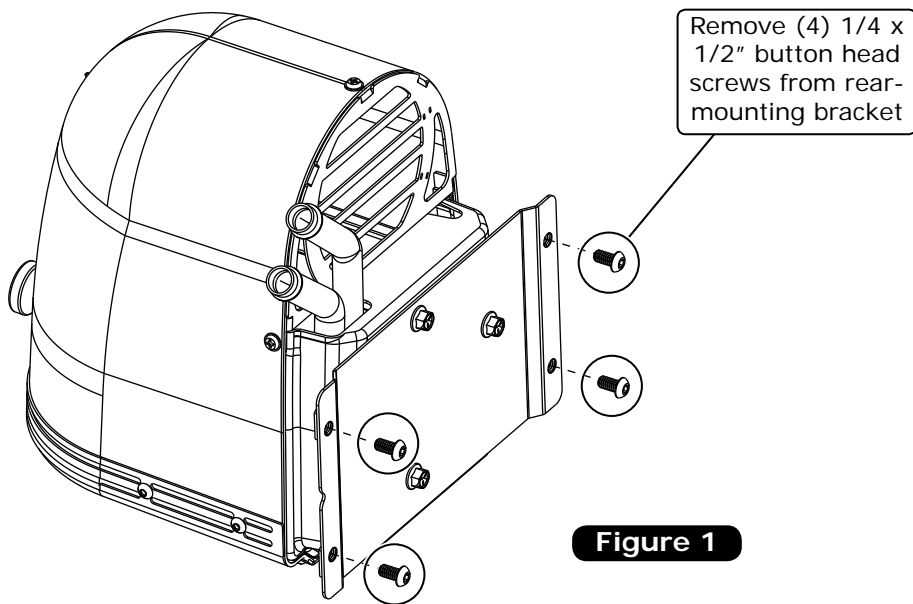



www.vintageair.com

Heater Hose and Heater Control Valve Installation

NOTE: Vintage Air systems use 5/8" heater connections. On engines equipped with 3/4" hose nipples, these will need to be removed and replaced with 5/8" nipples (not supplied). For water pumps with a cast-in 3/4" heater outlet, a 3/4" x 5/8" reducer fitting (not supplied) or molded hose will need to be installed in the heater hose.

1. Once the heater is in the desired location, prepare two heater hoses and find a location in the firewall to run the hoses and the heater control valve connector through. If drilling new holes, you must drill (2) 1 1/4" holes for the heater hose grommets and (1) 5/8" hole for the wiring grommet. **NOTE: Be sure to find a good location for the heater hose's holes, making sure that the hoses will not be kinked after installing it on the heater lines. Remove the rubber plugs from the heater nipples before connecting the hoses. Coil is shipped under pressure, be careful when removing the rubber plugs from the heater.**
2. Once the hoses have been prepared and measured, remove the heater from the firewall to have access to install the heater hoses to the heater coil lines.
3. Insert a rubber grommet onto the heater hose and route it from the water pump to the bottom heater coil line as shown in Figure 3, below, and secure using (2) hose clamps.
4. Insert a rubber grommet onto the heater hose and route it from the intake to the top heater coil line as shown in Figure 3, below. Secure using (2) hose clamps (See Figure 3, below).
5. Reinstall the heater unit using the provided (4) button head screws.
6. From the engine compartment, cut the intake heater hose approximately 5" from the firewall and install the heater control valve in-line with the proper flow direction using (2) hose clamps (See Figure 3, below). **NOTE: Do not overtighten clamps.**

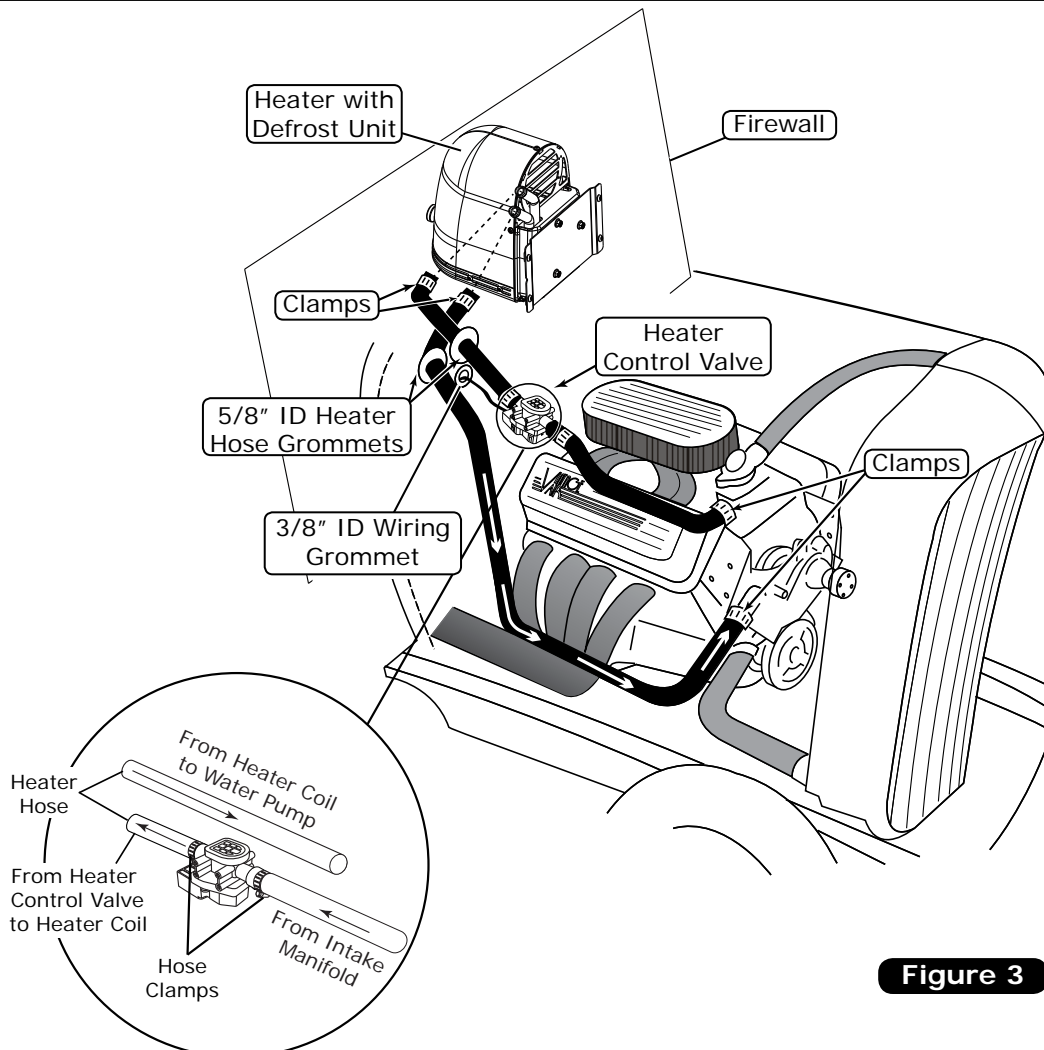

Figure 3



www.vintageair.com

Wiring Installation

1. Disconnect the battery.
2. Determine the desired route from the streamline heater unit to your chosen fused and switched power source, as well as a suitable ground.
3. If no fused source is available, utilize provided fuse accessories and connect to your chosen power source.
4. Connect the white ground wire to a reliable ground source within the cabin.
5. Assemble the wiring grommet onto the heater control valve (HCV) wiring. **NOTE: Use caution to not damage the connector or contacts.**
6. Route the HCV connector through the 5/8" hole in the firewall and install the grommet onto the firewall.
7. Inside the cabin, connect the HCV connectors.

NOTE: To avoid excessive key-off current, it is very important that the red power wire on this harness is connected to a switched ignition source that turns off with the ignition switch.

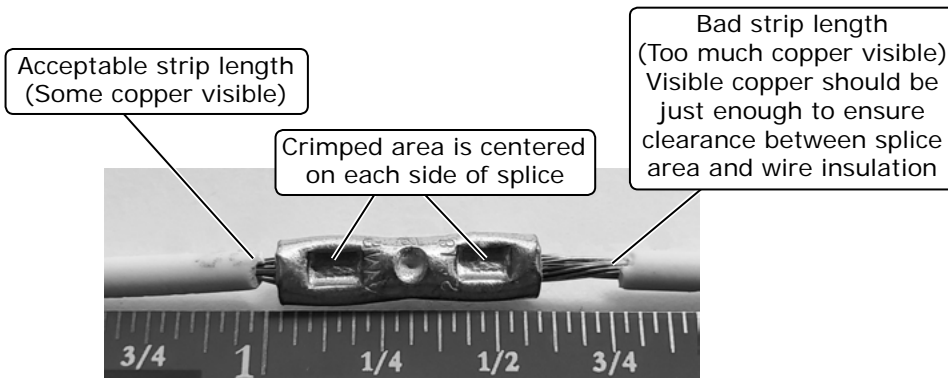

Photo 1

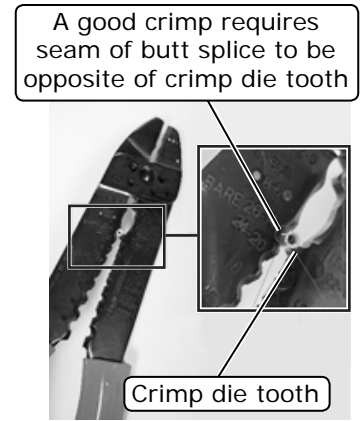

Photo 2

Good Ring Terminal Crimp

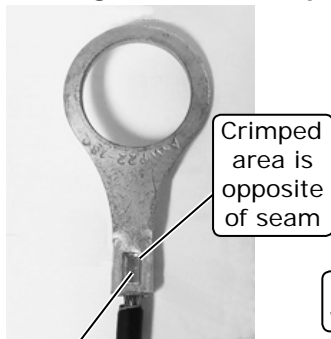

Photo 3

Bad Ring Terminal Crimp

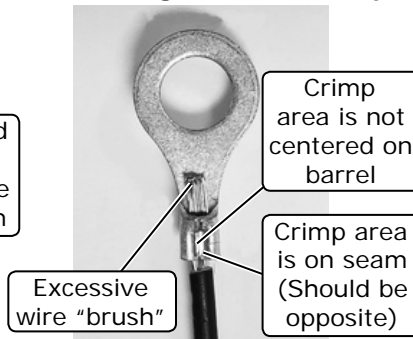
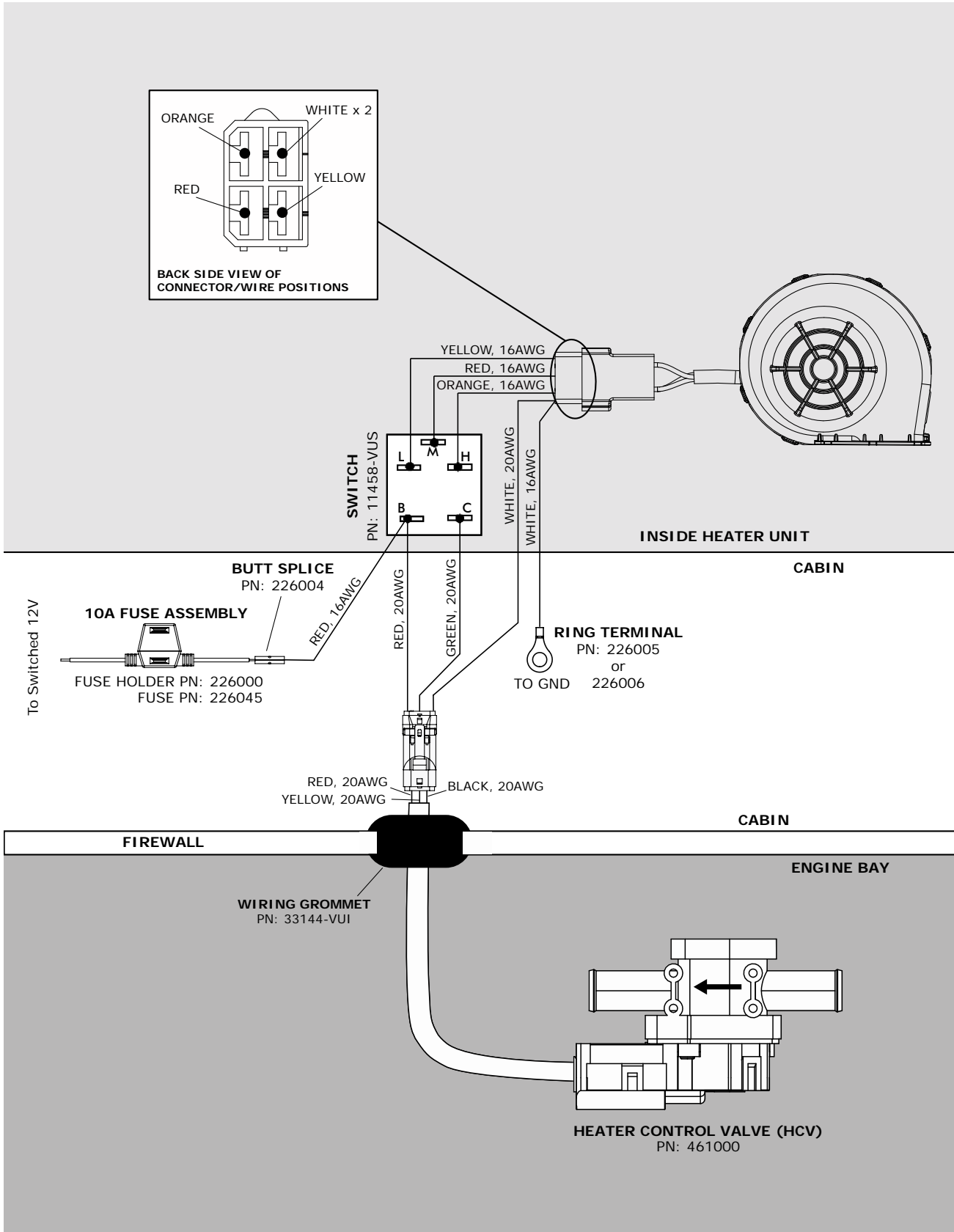

Photo 4



Wiring Diagram





www.vintageair.com

Final Steps

1. The switch knob has a protective film. Remove this film before operating (See Photo 1, below). **NOTE: Do not use sharp objects.**
2. Fill the radiator with coolant, and check all heater connections for leaks.
3. Start the engine and run it until normal operating temperature is reached. Turn on the switch by rotating it to the right; the switch has three fan speeds (OFF, 1, 2 and 3). The heater will start heating the vehicle.
4. When the valve is closed the inlet side of the valve should be hot and the outlet side should be cool. When the valve is open, both the inlet and outlet sides should be hot.



Photo 1

Control Panel Operation

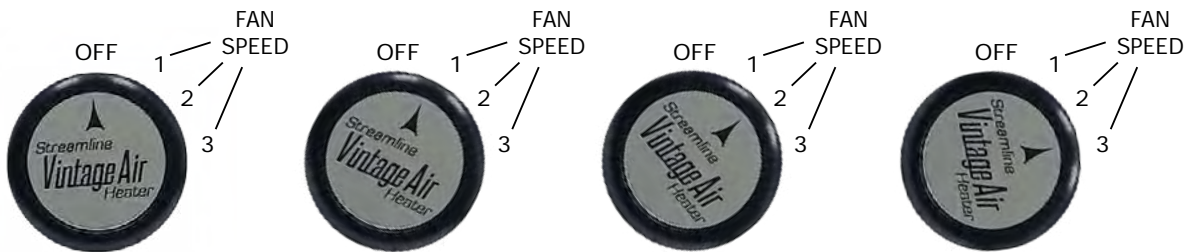



www.vintageair.com

Packing List: Heater Kit (660066)

No.	Qty.	Part No.	Description
1.	1	660065	Streamline Heater
2.	1	231089	Wiring and Hardware Kit

Checked By: _____
 Packed By: _____
 Date: _____

1



2

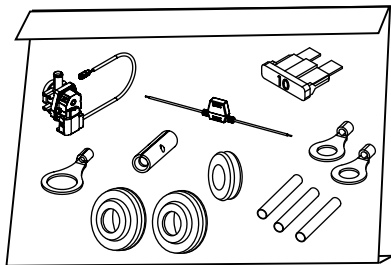

NOTE: Images may not depict actual parts and quantities.
 Refer to packing list for actual parts and quantities.