



PART#9906
MOTOR MOUNT KIT (Mount Brackets & Pads)

PART#9926
MOTOR MOUNT BRACKETS (NO Pads)

CHEVY SMALL BLOCK V8 ENGINE INTO A TWO-WHEEL DRIVE 1982-2004 CHEVY S-10 OR GMC S-15, USING A TH350 OR 700R4 AUTOMATIC TRANSMISSION.

THIS KIT INCLUDES:

Qty.	Part No.	Description	Qty.	Part No.	Description
1	9926	Pair of Engine Mount Brackets	2	HDW421	7/16" Flat Washers
6	HDW366	3/8 - 16 x 1" Grade 8 Hex Head Bolts	2	HDW422	7/16" Lock Washers
6	HDW321	3/8" Lock Washers	2	HDW053	7/16" - 14 Lock Nuts
2	HDW969	7/16" - 14 x 5" Grade 8 Hex Bolts	2	4217	Mount Pads (9906 Only)

Note: This motor mount kit (or bracket set) is for use during the installation of a Small Block Chevy V8 into the vehicles listed above. The use of properly configured engine mounts is only one of many aspects of this engine swap. Modification to various components(i.e. firewall, transmission crossmember), or the use of special aftermarket products designed for this engine swap will likely be required. This instruction sheet deals with the safe, and proper installation of Trans-Dapt's motor mount kit only. For comprehensive, step-by-step directions, and useful tips for performing this complex project, we recommend the use of a V8 engine swap how-to guide.

Important Information Regarding Engine Position

These motor mount brackets offer two engine height positions. The bottom hole is for stock engine height. The slotted hole raises the engine position by 1" to provide additional ground, firewall and header clearances. To use the stock engine position the brackets must be modified as shown below. (figure A)

#9906
INSTALLATION INSTRUCTIONS

Determine which mounting bracket mounting position better fits your situation, and modify the bracket, if needed. Do not install the brackets directly to the engine at this time.

Bolt the new motor mount pads to the stock location on the frame, using the factory pad bolts. Attach the 9926 mounting brackets to the new pads using the 7/16"-14 X 5" hex head bolts, washers and lock nuts, included with the kit. The bolts go through the rubber mount pads, and the Trans-Dapt Performance mount brackets.

Once the mount brackets are bolted to the rubber mounts, the engine can then be positioned into the chassis, and the mounting brackets can be bolted to the engine block for final assembly, using the 3/8"-16x1" grade 8 bolts and lock washers.

#9926
INSTALLATION INSTRUCTIONS

2.2L 4 Cylinder Models

If you are installing the V8 into a 2.2L 4 cylinder model, you will need a set of Trans-Dapt #4217 mount pads.

These Trans-Dapt Performance engine mount brackets install using the stock 2.8 liter V6 engine rubber mount pads.

Install the mounting brackets following the instructions for the Trans-Dapt Performance engine mount brackets #9906 on this page, substituting the stock 2.8L V6 mount pads for the Trans-Dapt #4217 mount pads. It may be necessary to grind the small metal tabs on either side of the stock mount pads to fit the Trans-Dapt performance mount brackets.

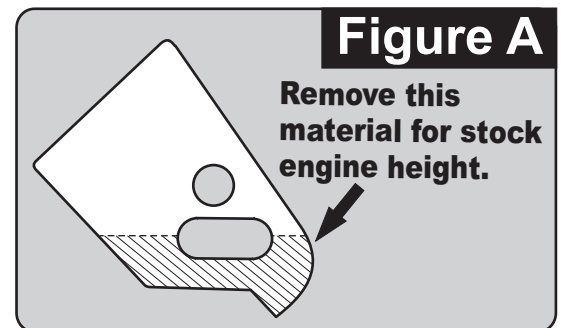
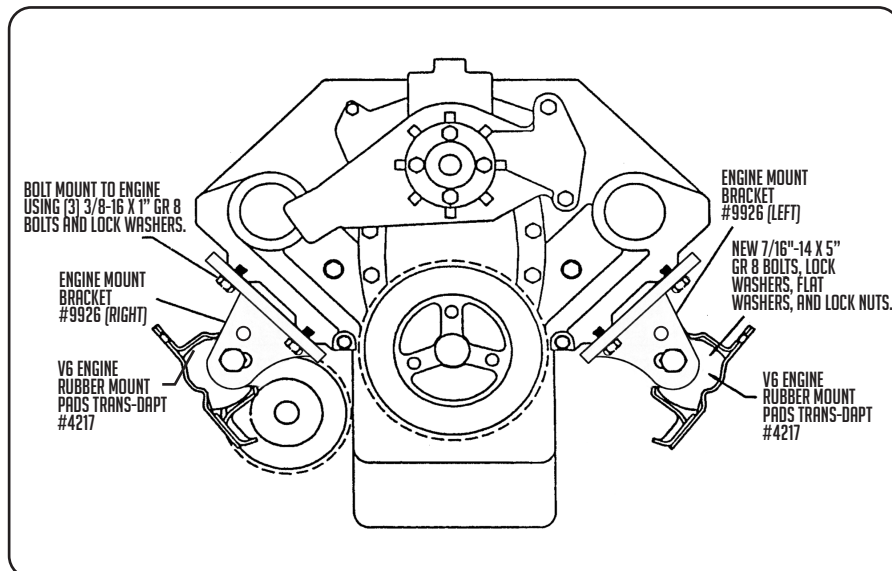

IMPORTANT

This product has been designed for a specific application combination. Modifications to any of the components will void the product warranty and return privileges. If you have questions regarding the installation of this product, it is strongly recommended that you contact the Trans-Dapt tech support team at: techsupport@tdperformance.com

TRANS-DAPT PERFORMANCE PRODUCTS

12438 Putnam Street, Whittier, CA 90602 tel (562) 921-0404 fax (562) 921-7515
 website: www.tdperformance.com email: techsupport@tdperformance.com