

IMPORTANT ALERT: GM uses a very strong thread-locking compound on all body bolts. Use of an air assisted impact ratchet can cause damage to the threads on factory body mount bolts and the internal nut assembly because of this thread locking compound.

We only recommend the use of hand tools to slowly remove and reinstall body mount bolts on all GM vehicles.

PROCEDURE:

CRITICAL INFORMATION: If during the removal process, it becomes increasingly difficult to unscrew the body mount bolt with hand tools, tighten the bolt several rotations to clear the thread locking compound from the threads, then reverse direction and continue to unscrew until the body mount bolt is out. Repeat this process as necessary on all GM body mount bolts. Use of an appropriate anti-seize compound is highly recommended for re-installation. Tighten body mount bolt to factory torque specifications for your particular model year.

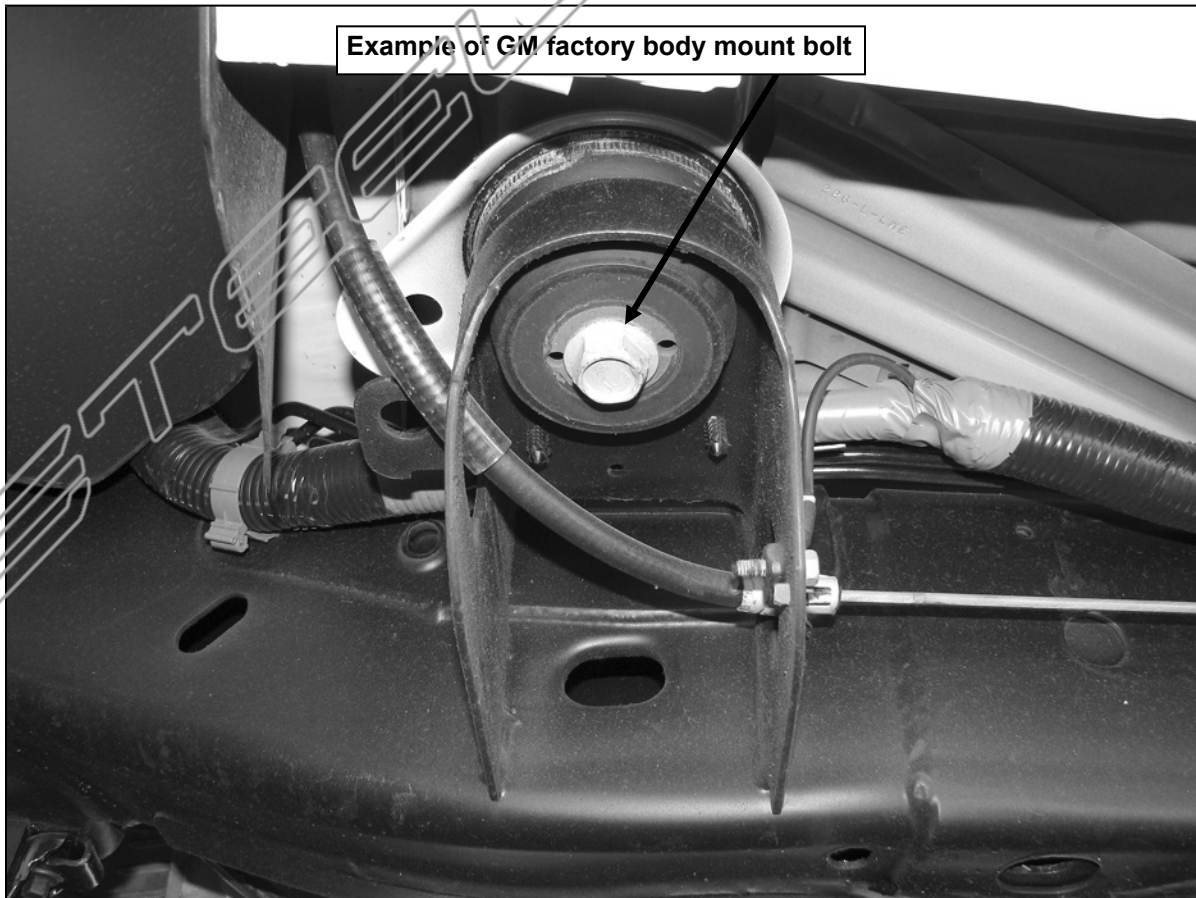

PARTS LIST:

1	Driver/Left Sidebar	4	1/2" x 2" Hex Head Bolts
1	Passenger/Right Sidebar	4	1/2" Lock Washers
1	Driver/Left Front Mounting Bracket	4	1/2" ID x 1-1/2" OD x 1/8" Flat Washers
1	Passenger/Right Front Mounting Bracket	2	10mm x 25mm Bolt Plates
1	Driver/Left Rear Mounting Bracket	2	10-1.50mm x 30mm Hex Head Bolts
1	Passenger/Right Rear Mounting Bracket	4	10mm Lock Washers
1	Driver/Left Front Support Bracket	4	10mm Hex Nuts
1	Passenger/Right Front Support Bracket	4	10mm ID x 30mm OD x 2.5mm Flat Washers
		4	12-1.75mm x 120mm Hex Head Bolts
		4	12mm Lock Washers
		4	12mm ID x 32mm OD x 3mm Flat Washers

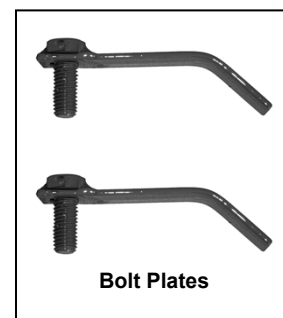
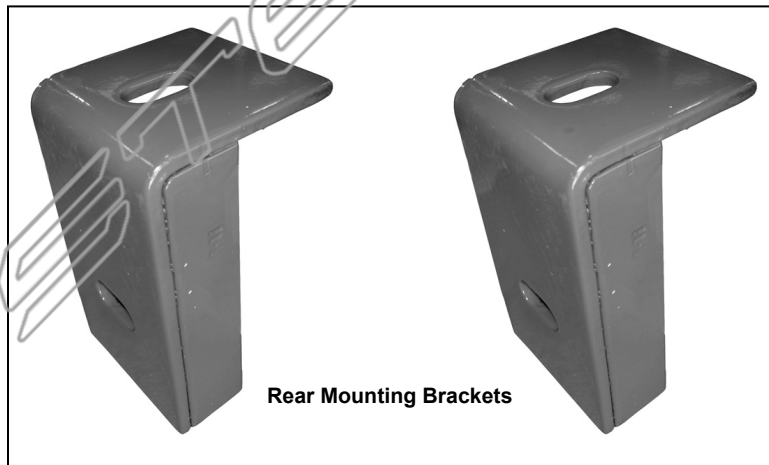
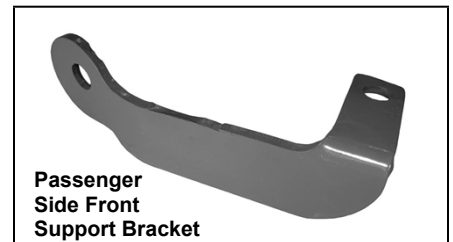
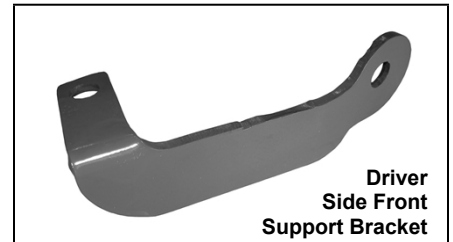
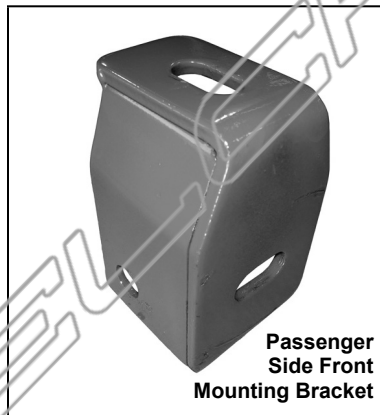

PROCEDURE:

- 1. REMOVE CONTENTS FROM BOX. VERIFY ALL PARTS ARE PRESENT. READ INSTRUCTIONS CAREFULLY BEFORE STARTING INSTALLATION.**
- From underside of vehicle remove the driver's side body mounts bolts. Keep factory washers and rubber bushings in place.
- Partially attach driver's side front and rear Mounting Brackets as shown in **Figure 1 & 2**.
NOTE: For 06-On vehicles, use existing factory body mount bolts to attach Mounting Brackets to the vehicle. For all other applications, use the included (4) 12mm x 120mm Hex Head Bolts, (4) 12mm Flat Washers, and (4) 12mm Lock Washers.
- Attach driver Sidebar to Mounting Brackets using the included (2) ½" x 2" Hex Head Bolts, (2) ½" Lock Washers, and (2) ½" Flat Washers (**Figure 3**). Do not tighten at this time.
- Locate the factory slotted and rounded hole on the bottom of the frame by the front body mount. Insert (1) Bolt Plate through slotted hole so bolt drops through rounded hole (**Figure 4**).
- Partially attach driver side front Support Bracket to already inserted Bolt Plate using the included (1) 10mm Lock Washer, (1) 10mm Hex Nuts, and (1) 10mm Flat Washer. Attach opposite side of front Support Bracket to front Mounting Bracket using the included (1) 10mm x 30mm Hex Head Bolt, (1) 10mm Lock Washer, (1) 10mm Flat Washer, and (1) 10mm He Nut (**Figure 5**).
- Adjust the Sidebar properly; and then tighten all hardware at this time.
- Repeat steps 2 – 7 for passenger Sidebar.
- Do periodic inspections to the installation to make sure that all hardware is secure and tight.

To protect your investment, wax this product after installing. Regular waxing is recommended to add a protective layer over the finish. Do not use any type of polish or wax that may contain abrasives that could damage the finish.

For stainless steel: Aluminum polish may be used to polish small scratches and scuffs on the finish. Mild soap may be used also to clean the Sidebar.

For gloss black finishes: Mild soap may be used to clean the Sidebar

(Driver Side Installation Shown)

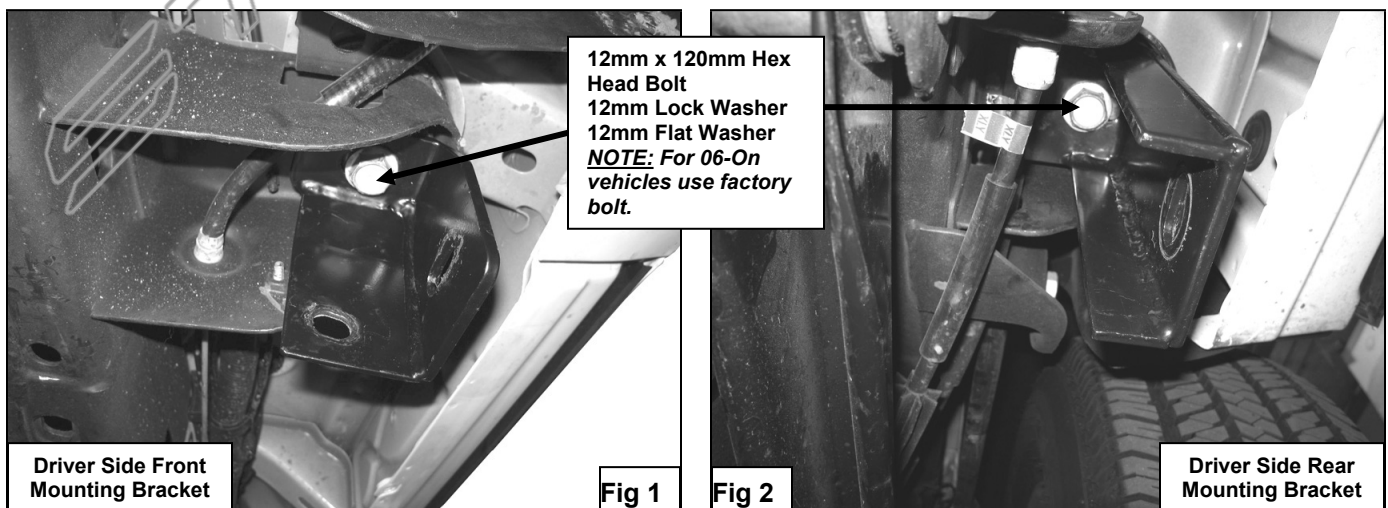

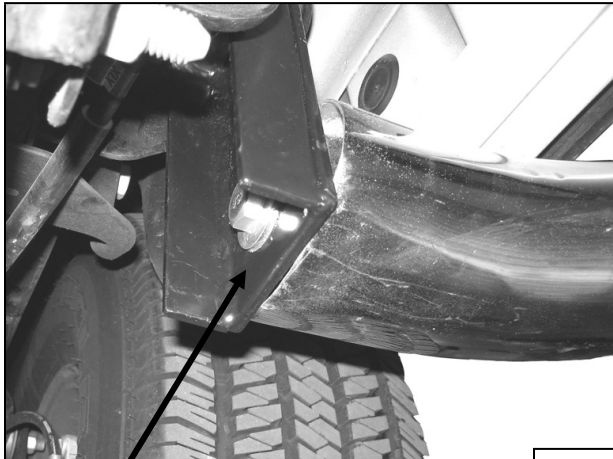

Fig 3

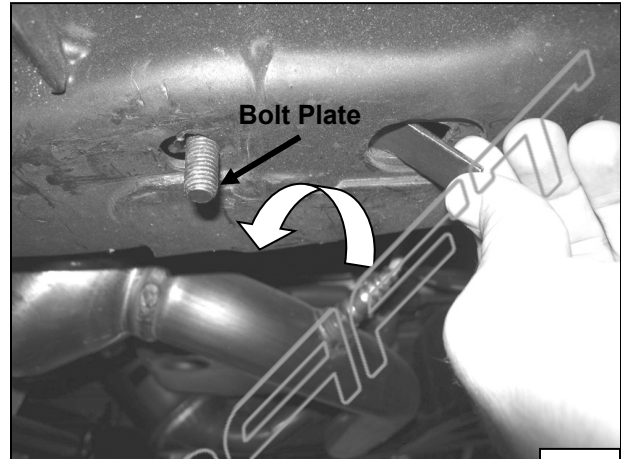

Fig 4

1/2" x 2" Hex Head Bolt
 1/2" Lock Washer
 1/2" Flat Washer

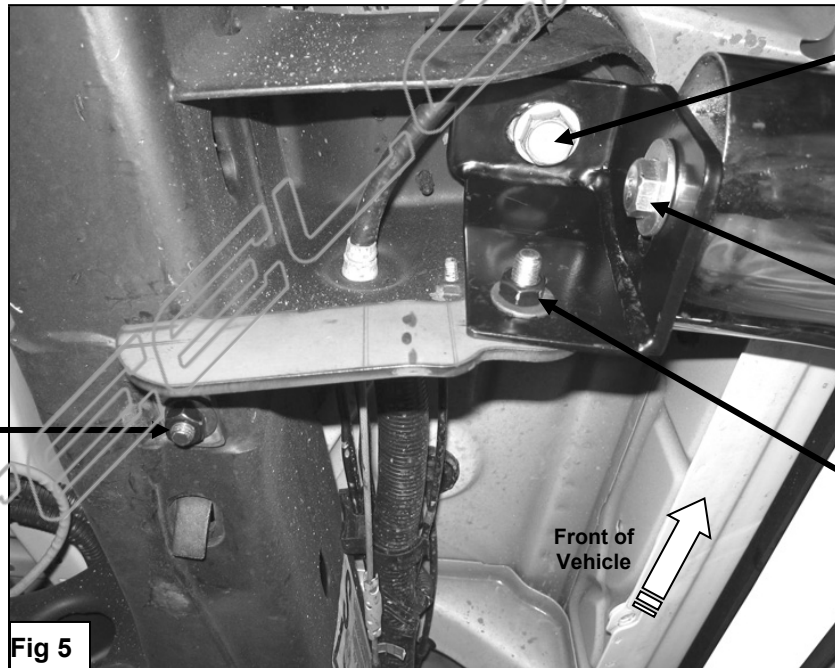

Fig 5

12mm x 120mm Hex Head Bolt
 12mm Lock Washer
 12mm Flat Washer
 NOTE: For 06-On vehicles use factory bolt.

1/2" x 2" Hex Head Bolt
 1/2" Lock Washer
 1/2" Flat Washer

10mm x 30mm Hex Head Bolt
 10mm Lock Washer
 10mm Flat Washers
 10mm Hex Nut

(Bolt Plate)
 10mm Lock Washer
 10mm Flat Washer
 10mm Hex Nut

Front of Vehicle



Fig 6

Installation Complete