

PARTS LIST:

1	Bumper Center Section	20	10mm x 24mm OD x 2.2mm Flat Washers
1	Driver/Left Full Width Wing	10	10mm Lock Washers
1	Passenger/Right Full Width Wing	10	10mm Hex Nuts
1	Driver/Left Stubby End Cap	1	8-1.25mm x 25mm Hex Bolt
1	Passenger/Right Stubby End Cap	1	8mm x 24mm OD x 2mm Flat Washers
1	Light Bar for Center Section	1	8mm Lock Washer
1	Vac Pump Support Bracket	1	6-1.0mm x 35mm Hex Bolt
1	Vac Pump Rectangular Fill Plate (Support Bracket)	2	6mm x 22mm OD x 2mm Flat Washers
10	12-1.75mm x 35mm Hex Bolts	1	6mm Nylon Lock Nut
18	12mm x 24mm OD x 2.5mm Flat Washers	6	4mm x 20mm Button Head Screws
10	12mm Lock Washers	12	4mm x 8.65mm x 8mm Flat Washers
8	12mm Hex Nuts	6	4mm Nylon Lock Nuts
10	10-1.5mm x 35mm Hex Bolts	1	Wrench

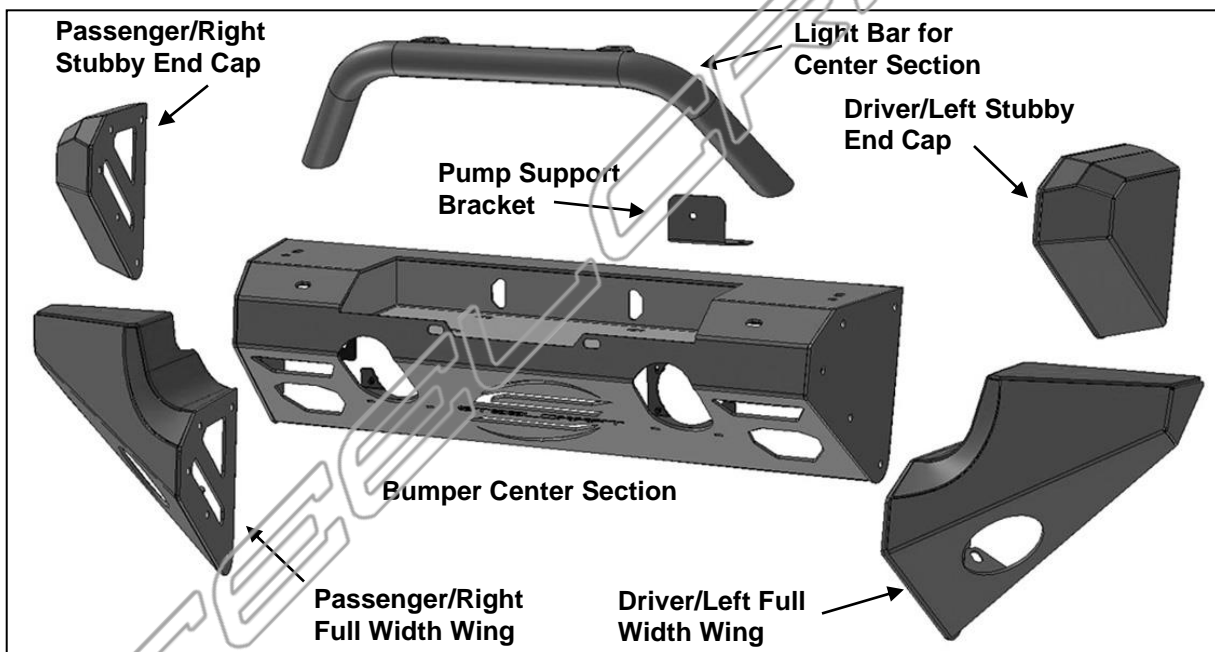

PROCEDURE:

- 1. REMOVE CONTENTS FROM BOX. VERIFY ALL PARTS ARE PRESENT. READ INSTRUCTIONS CAREFULLY BEFORE STARTING INSTALLATION. CUTTING MAY BE REQUIRED. ASSISTANCE IS RECOMMENDED.**
2. Start under the front bumper of the vehicle and remove the plastic lower splash guard, **(Figure 1)**.
3. On models with factory fog lights, unplug fog lights before removing bumper, **(Figure 2)**.
4. Remove the clips fastening the plastic fill panel to the top of frame behind the bumper. Slide fill panel left or right to access bumper hardware from above, **(Figure 3)**. **NOTE:** Bumper mounting hardware can also be accessed from below. Remove the front bumper assembly, **(Figures 2, 4 & 5)**. Move the bumper to a stable surface. Remove fog lights if equipped, **(Figure 5)**.
5. **On 2012-up models**, locate the vacuum pump attached to the inside of the driver side of the frame, **(Figure 6)**. Remove the hardware attaching the pump to the bracket and move the pump out of the way. Cut the **forward** mounting tab off of the bracket welded to the frame, **(Figure 7)**. **IMPORTANT:** Do not remove the rear mounting tab, only cut off the forward, (closest to the bumper), mounting tab. If necessary, hold the Bumper center section up in position to determine how much of the mounting tab will need to be removed to clear the back of the Bumper.
6. Select the pump relocating Bracket, **(Figure 8)**. Use the factory hardware to reattach the pump to the remaining rear mounting tab. Attach the Relocating Bracket to the bottom of the bushing on the pump with

**MODULAR FRONT BUMPER
07-16 JEEP J/K WRANGLER**

(1) 6mm x 35mm Hex Bolt, (2) 6mm Flat Washers and (1) 6mm Nylon Lock Nut. Snug but do not fully tighten hardware at this time.

7. Carefully unwrap the Modular Bumper Center Section, End Covers, Full Bumper End Wings and Light Mount Loop. Move the Modular Bumper to a clean stable work surface. **NOTE:** Assemble Bumper before installing on vehicle.
8. Determine desired configuration for Bumper assembly.
To install Light Mount Loop:
 - a. Attach Loop to mounting holes in top of Center Section with (2) 12mm x 35mm Hex Bolts, (2) 12mm Lock Washers and (2) 12mm Flat Washers, **(Figure 9)**.
 - b. Center the Loop on the Bumper and fully tighten Loop mounting hardware.**To install end caps or full bumper ends:**
 - a. Select the driver side Stubby End Cap or Bumper End. Attach the End Cap/Bumper End to the Center Section with (5) 10mm x 35mm Hex Bolts, (10) 10mm Flat Washers, (5) 10mm Lock Washers and (5) 10mm Hex Nuts, **(Figures 10 & 11)**. **NOTE:** Insert each Hex Bolt with Flat Washer into the Center Section and out through the End Cap/Bumper End.
 - b. Line up the edges of the End Cap/Bumper End with the Center Section and slowly tighten the hardware.
 - c. Repeat the above **Steps a & b** for passenger side installation.
9. Install the factory fog lights (if equipped) into the mounting brackets in the back of the center section with (6) 4mm x 20mm Button Head Screws, (12) 4mm Flat Washers and (6) 4mm Nylon Lock Nuts, **(Figure 12)**. **IMPORTANT:** Do not overtighten fog light hardware or damage to the fog light may result.
10. With assistance, move Bumper to vehicle once it has been completely assembled. Line up the mounting brackets on the back of the Center Section with the ends of the frame. Attach the Bumper assembly to the frame with (8) 12mm x 35mm Hex Bolts, (16) 12mm Flat Washers, (8) 12mm Lock Washers and (8) 12mm Hex Nuts, **(Figure 13)**. **NOTE:** Depending on model year, Bumper may attach to end of frame with 2—4 hex bolts per side. Adjust quantity of hardware as required. Do not fully tighten hardware at this time.
11. Stand back from the vehicle and check to see that the Bumper Assembly is centered and level on the vehicle and adjust as required. Once properly aligned, fully tighten all hardware.
12. **On 2012-up models**, move the vacuum pump and relocating bracket up to the back of the Center Section. Line up the mounting hole on the Bracket with the large opening in the back of the center section. Attach the Relocation Bracket to the center section with (1) 8mm x 25mm Hex Bolt, (1) 8mm Lock Washer, (1) 8mm Flat Washer and (1) Rectangular Spacer, **(Figure 14)**. Once properly lined up, fully tighten the hardware attaching the vacuum pump to the frame and brackets.
13. Reattach the wiring harness for the fog lights if equipped.
14. Do periodic inspections of the installation to make sure that all hardware is secure and tight.
15. On Bumper with full width end wings, Bumper Ends are equipped with universal tabs for most 4" round lights, (not included). Follow manufacturer's guide for installation and wiring instructions.

To protect your investment, wax this product after installing. Regular waxing is recommended to add a protective layer over the finish. Do not use any type of polish or wax that may contain abrasives that could damage the finish. Mild soap may be used to clean the Bumper assembly.

Passenger Side Installation Pictured



(Fig 1) Remove plastic splash guard from bumper

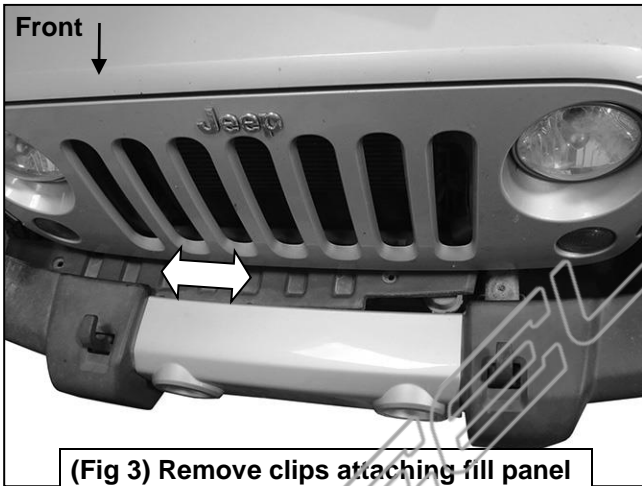

(Fig 3) Remove clips attaching fill panel to top of frame. Slide panel left or right to access bumper bolts from above



(Fig 5) Remove fog lights if equipped



(Fig 2) Unplug fog lights if equipped (passenger side inner bumper bolts pictured)

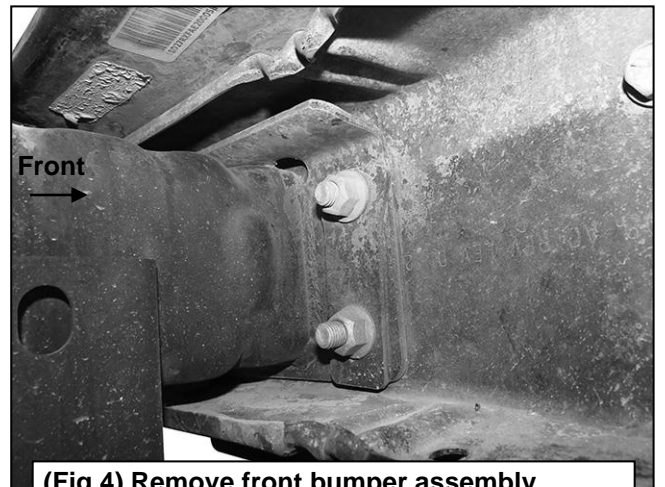

(Fig 4) Remove front bumper assembly (passenger side outer bumper bolts pictured)

Passenger Side Installation Pictured



(Fig 6) On 2012-on models, temporarily remove valve from driver side frame

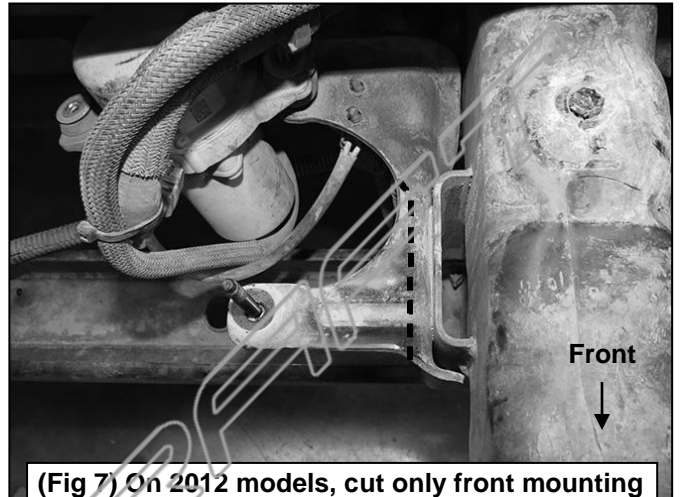

(Fig 7) On 2012 models, cut only front mounting tab off of frame (dashed line for example only)

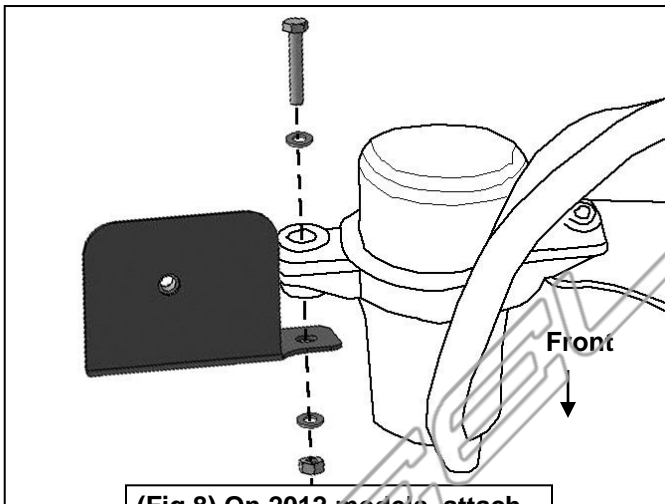

(Fig 8) On 2012 models, attach Support Bracket to valve

- (2) 12mm x 35mm Hex Bolts
- (2) 12mm Lock Washers
- (2) 12mm Flat Washers
- (see hardware kit #2)

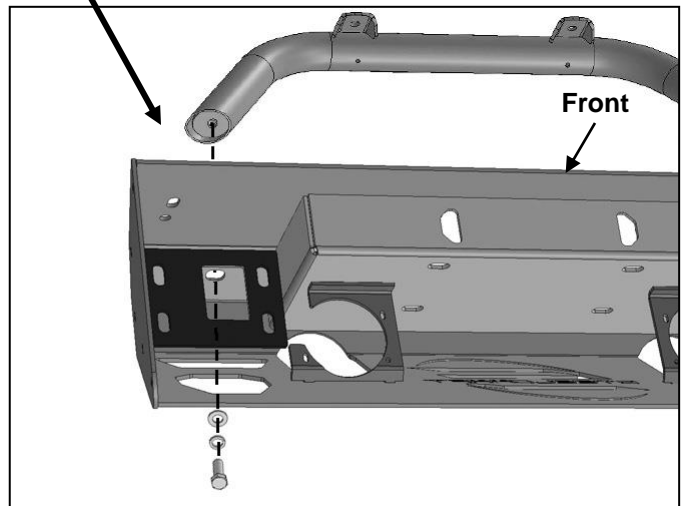

(Fig 9) Attach Light Bar to top of Bumper center section

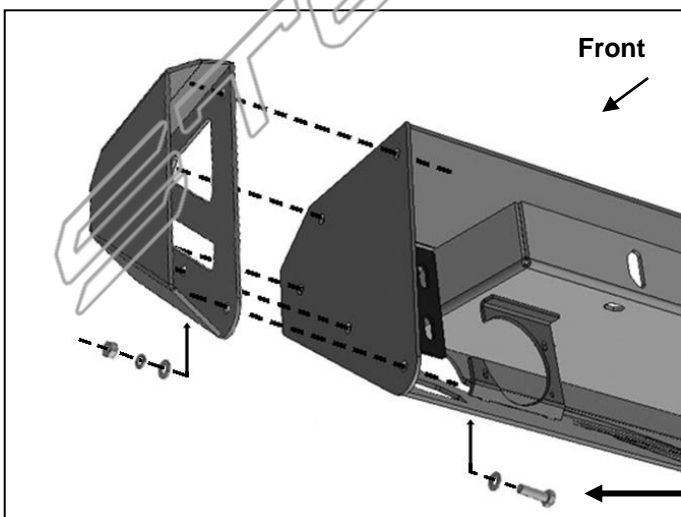

(Fig 10) Driver/left End Cap installation

- (5) 10mm x 35mm Hex Bolts
- (10) 10mm Flat Washers
- (5) 10mm Lock Washers
- (5) 10mm Hex Nuts
- (see hardware kit #1)

Passenger Side Installation Pictured

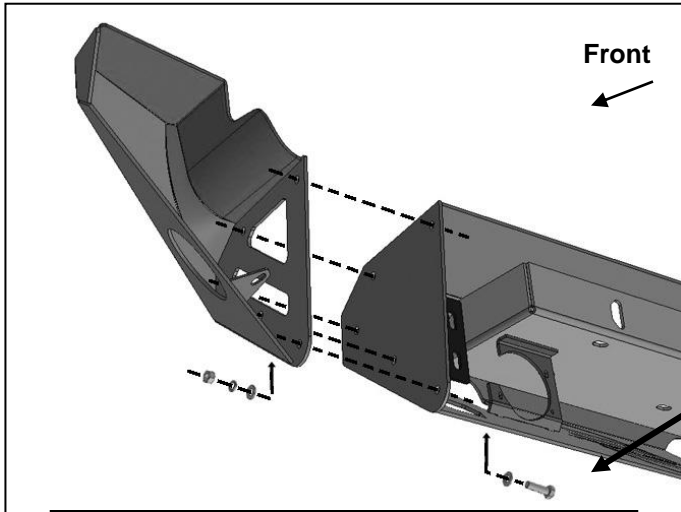

(Fig 11) Driver/left Bumper Wing installation

Bumper Wing (Fig 11) is designed to accept most universal 3-4" round flood/fog lights (not included). Follow manufacturer's guide for installation and wiring instructions

- (5) 10mm x 35mm Hex Bolts
- (10) 10mm Flat Washers
- (5) 10mm Lock Washers
- (5) 10mm Hex Nuts

- (3) 4mm x 20mm Button Head Screws
- (6) 4mm Flat Washers
- (3) 4mm Nylon Lock Nuts

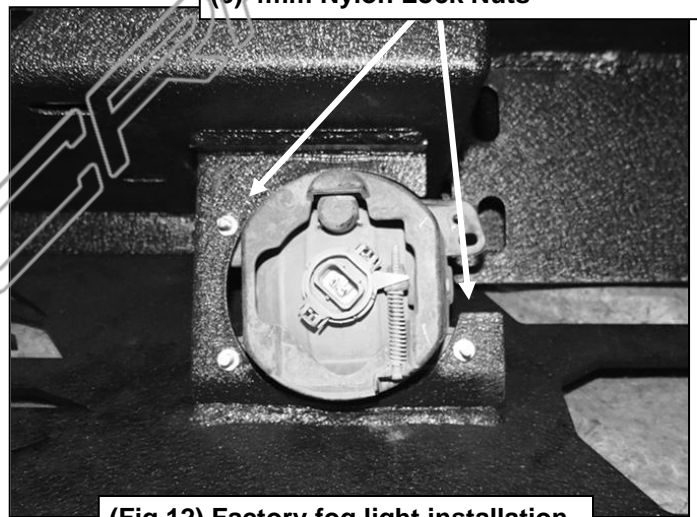

(Fig 12) Factory fog light installation

- 12mm x 35mm Hex Bolts
- 12mm Flat Washers
- 12mm Lock Washers
- 12mm Hex Nut

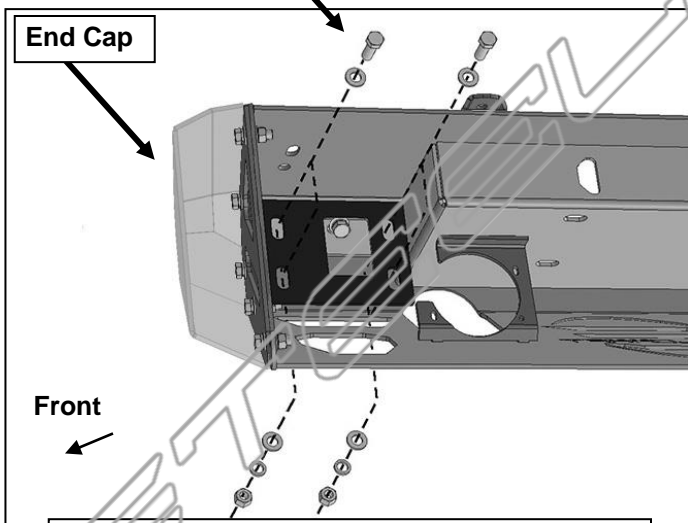

(Fig 13) Attach Bumper assembly to bumper mounting plates on ends of frame. Depending on model/year, installation may require 2-4 Hex Bolts per factory bumper mounting plate

- 8mm x 25mm Hex Bolt
- 8mm Lock Washer
- 8mm Flat Washer
- 8mm Rectangular Fill Plate for Valve Support Bracket

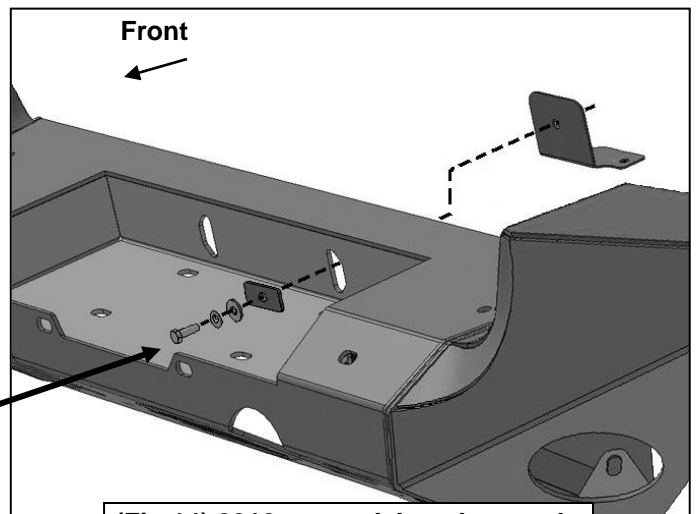

(Fig 14) 2012-on models only, attach Support Bracket to back of bumper after Bumper assembly installation