

Specifications

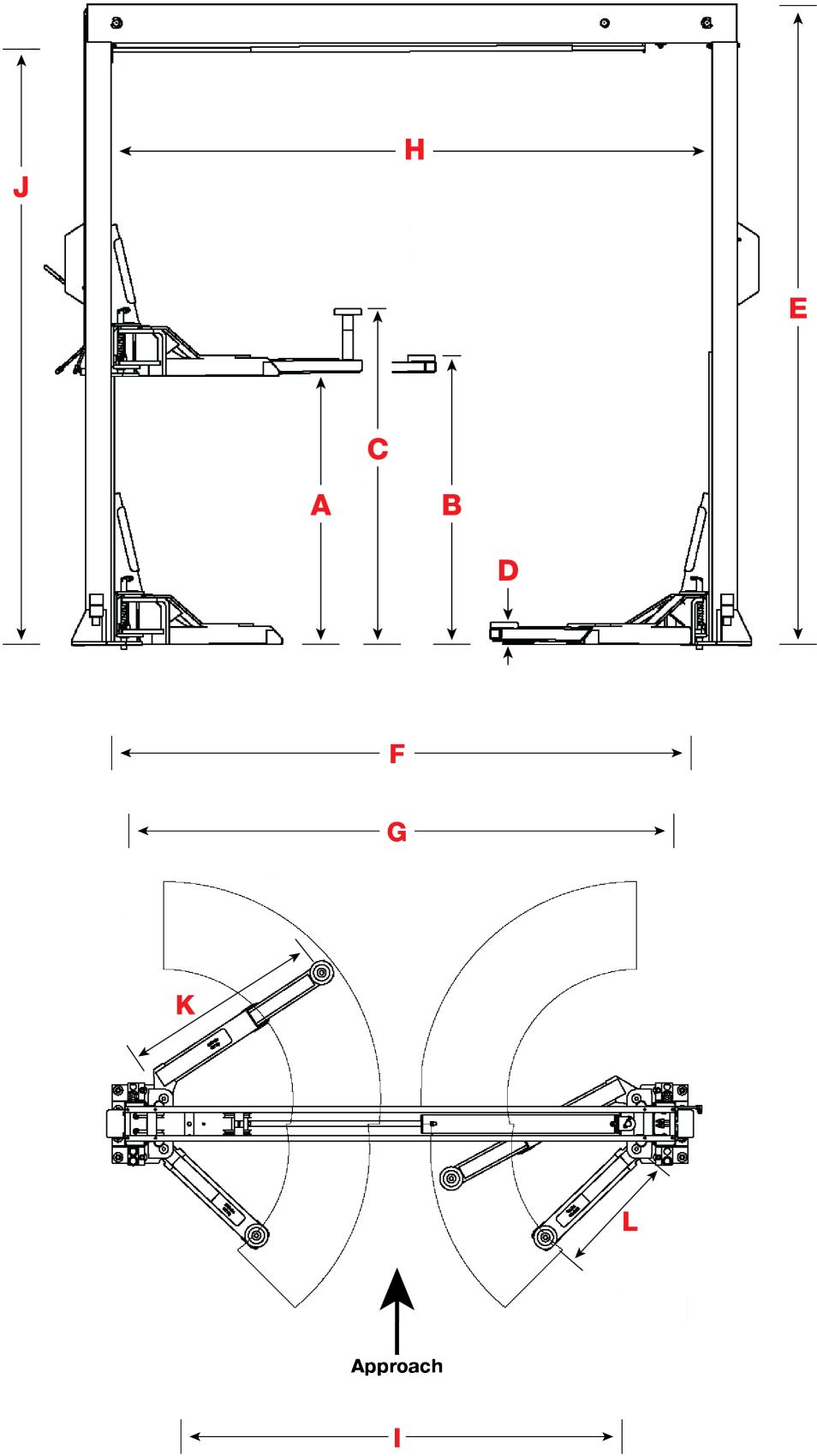

Model	GP-7LCS	GP-7LC	GP-7
Lifting capacity	7,000 lbs / 3,175 kg		
A – Rise	54" / 1,372 mm	64" / 1,626 mm	74" / 1,880 mm
B – Rise + pad	58" / 1,473 mm	68" / 1,727 mm	78" / 1,981 mm
C – Rise + pad + adapter	66" / 1,676 mm	76" / 1,930 mm	86.5" / 2,197 mm
D - Minimum pad height	4.5" / 114 mm		
E – Height overall	106.5" / 2,705 mm	118.5" / 3,010 mm	150" / 3,810 mm
F – Width overall	125" / 3,175 mm		
G - Outside posts	119.5" / 3,035 mm		
H – Inside posts	110" / 2,794 mm		
I - Drive-thru width	89.5" / 2,273 mm		
J - Floor to Trip Stop Tube	96" / 2,438 mm	108" / 2,743	140" / 3,556 mm
K - Reach (front arm min)	26" / 660 mm		
K - Reach (front arm max)	42" / 1,067 mm		
L - Reach (rear arm min)	28" / 711 mm		
L - Reach (rear arm max)	47.5" / 1,207 mm		
Standard Motor	220 VAC, 60 Hz, 1Ph		
Time to full rise	~45 seconds		
Maximum operating hydraulic pressure	2,940 PSI		
Sound	~70 dB		

Specifications subject to change without notice.