

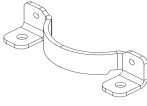

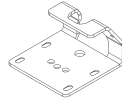

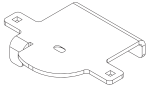











MAIN KIT CONTENTS:

PT # 6401	 x2 AIR SPRING	PT # 5897	 x4 CLAMP SPRING MOUNT	PT # 5898	 x2 UPPER BRACKET
PT # 5899	 x2 LOWER BRACKET	PT # 5900	 x4 HOOK SPRING MOUNT	PT # 9414	 x1 RED AIR LINE TUBE (18 FEET)
PT # 1004	 x1 HEAT SHIELD				

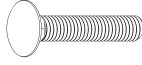
A24-760-7560 INFLATION VALVE BRACKET KIT

PT # 9483	 x1 NO-DRILL INFLATION VALVE BRACKET	PT # 9488	 x2 LARGE NYLON TIE
-----------	---	-----------	---

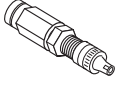
A21-760-2613 HARDWARE PACK

PT # 3046	 x2 AIR FITTING	PT # 3064	 x2 INTERNAL TOOTH LOCK WASHER	PT # 3513	 x4 1/4" - 20 x 2" HEX SCREW
PT # 3295	 x2 3/4" - 16 HEX NUT	PT # 3510	 x4 1/4" - 20 FLANGE NUT	PT # 3402	 x4 3/8" - 16 x 2" CARRIAGE BOLT
PT # 3033	 x4 5/16" FLAT WASHER	PT # 3514	 x8 3/8" - 16 x 1" FLAT HEAD SCREW	PT # 9036	 x6 RED NYLON TIE
PT # 3022	 x12 3/8" - 16 FLANGE LOCK NUT	PT # 3032	 x2 INFLATION VALVE AND VALVE CAP ASSEMBLY	PT # 0899	 x2 THERMAL SLEEVE
PT # 3142	 x2 3/8" - 16 x .625" FLAT HEAD BOLT				