

Exploded Assembly Diagram

WARNING
 INSTALLATION OF THIS KIT SHOULD **ONLY** BE PERFORMED BY PERSONS EXPERIENCED IN THE INSTALLATION AND PROPER OPERATION OF DISC BRAKE SYSTEMS.

NOTE
 SPECIFIC PARTS MAY VARY FROM DIAGRAM

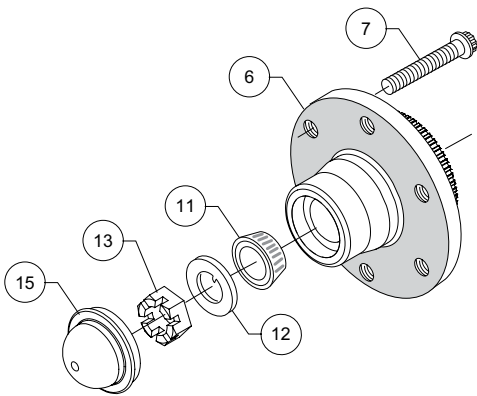

SRP DRILLED/SLOTTED PATTERN ROTOR

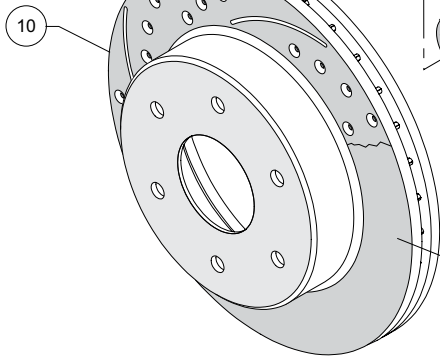

PLAIN FACE PATTERN ROTOR

OEM ABS SENSOR
 CUSTOMER SUPPLIED

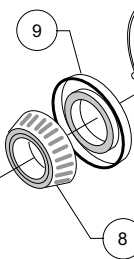

INCLUDED WITH WILWOOD PROSPINDLE
ADD LOCTITE® 271
 (SEE INSTRUCTIONS)

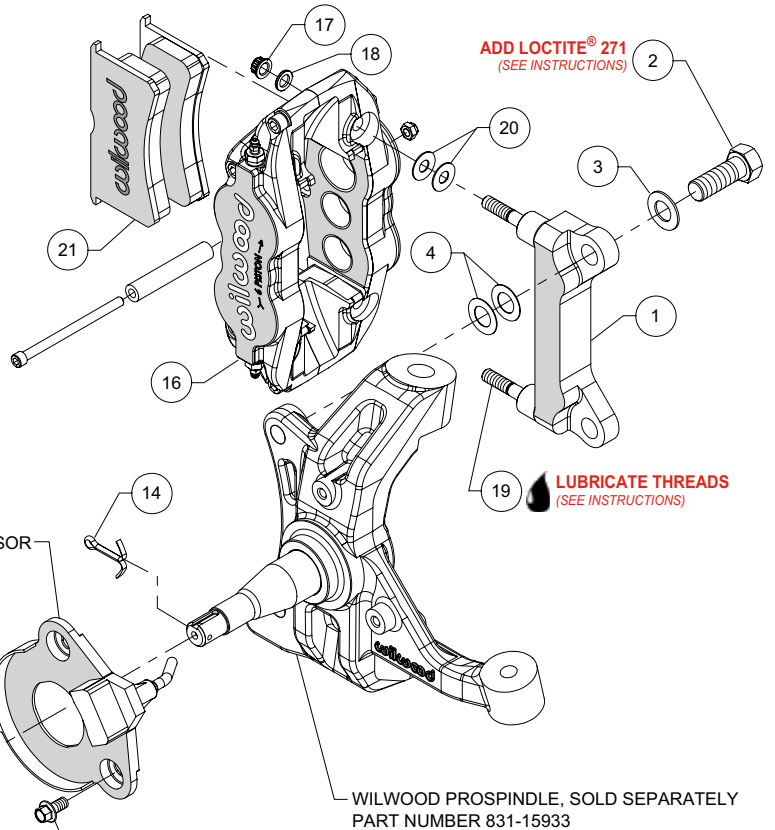

ADD LOCTITE® 271
 (SEE INSTRUCTIONS)

LUBRICATE THREADS
 (SEE INSTRUCTIONS)

WILWOOD PROSPINDLE, SOLD SEPARATELY
 PART NUMBER 831-15933

NOTE:
 RIGHT HAND VERSION SHOWN

Parts List

<u>ITEM NO.</u>	<u>PART NO.</u>	<u>DESCRIPTION</u>	<u>QTY</u>
1	250-14207	Bracket, Caliper Mounting	2
2	230-14217	Bolt, 5/8-18 x 1.50 Long, Hex Head	4
3	240-11856	Washer, .640" I.D. x 1.188" O.D. x .063" Thick	4
4	240-9074	Shim, .024" Thick	12
5	230-15934	Bolt, M8-1.25 x 16mm Long, Flanged Hex Head	4
6	270-15792	Hub, 6 on 5.50"	2
7	230-6959	Studs, Wheel	12
8	370-2609	Cone, Inner Bearing	2
9	380-10792	Seal, Grease	2
10	160-15782	Rotor, HP, 1.10" x 12.19" Diameter	2
10A	160-15784/85-BK	Rotor, Black, SRP Drilled and Slotted (one each, right and left)	2
11	370-9542	Cone, Outer Bearing	2
12	240-15900	Washer, Spindle, 3/4"	2
13	230-15901	Nut, Spindle, 3/4-16	2
14	180-15902	Cotter Pin, Spindle	2
15	270-15891	Cap, Dust	2
16	120-14539/40-BK	Caliper, Superlite 6R, Black (one each, right and left)	2
16A	120-14539/40-RD	Caliper, Superlite 6R, Red (one each, right and left)	2
17	230-9183	Nut, 3/8-24, Self-Locking, Hex Head	4
18	240-10190	Washer, .391" I.D. x .625" O.D. x .063" Thick	4
19	230-9078	Stud, 3/8-16 x 3/8-24 x 2.50" Long (pre installed in bracket)	4
20	240-1159	Shim, .035" Thick	12
21	150-8855K	Pad, BP-10 Compound, Axle Set	1

NOTES: P/N 230-15997 Bolt Kit, Wheel Studs includes part number 230-6959

P/N 230-15935 Bolt Kit (included with the ProSpindle kit), ABS Sensor, includes part number 230-15934

P/N 250-14208 Caliper Bracket Kit, includes P/N's 230-9078, 230-9183, 230-14217, 240-1159, 240-9074, 240-10190, 240-11856, and 250-14207

P/N 370-10763 Lock Nut Kit, includes part numbers 180-15902, 230-15901, 240-15900 and 270-15891

Item 10A is an optional item and included with the "-D" drilled rotor kits.

Add"-D" to end of part number when ordering.

Item 16A is an optional item and included with the "-R" red caliper kits.

Add"-R" to end of part number when ordering.