

Exploded Assembly Diagram

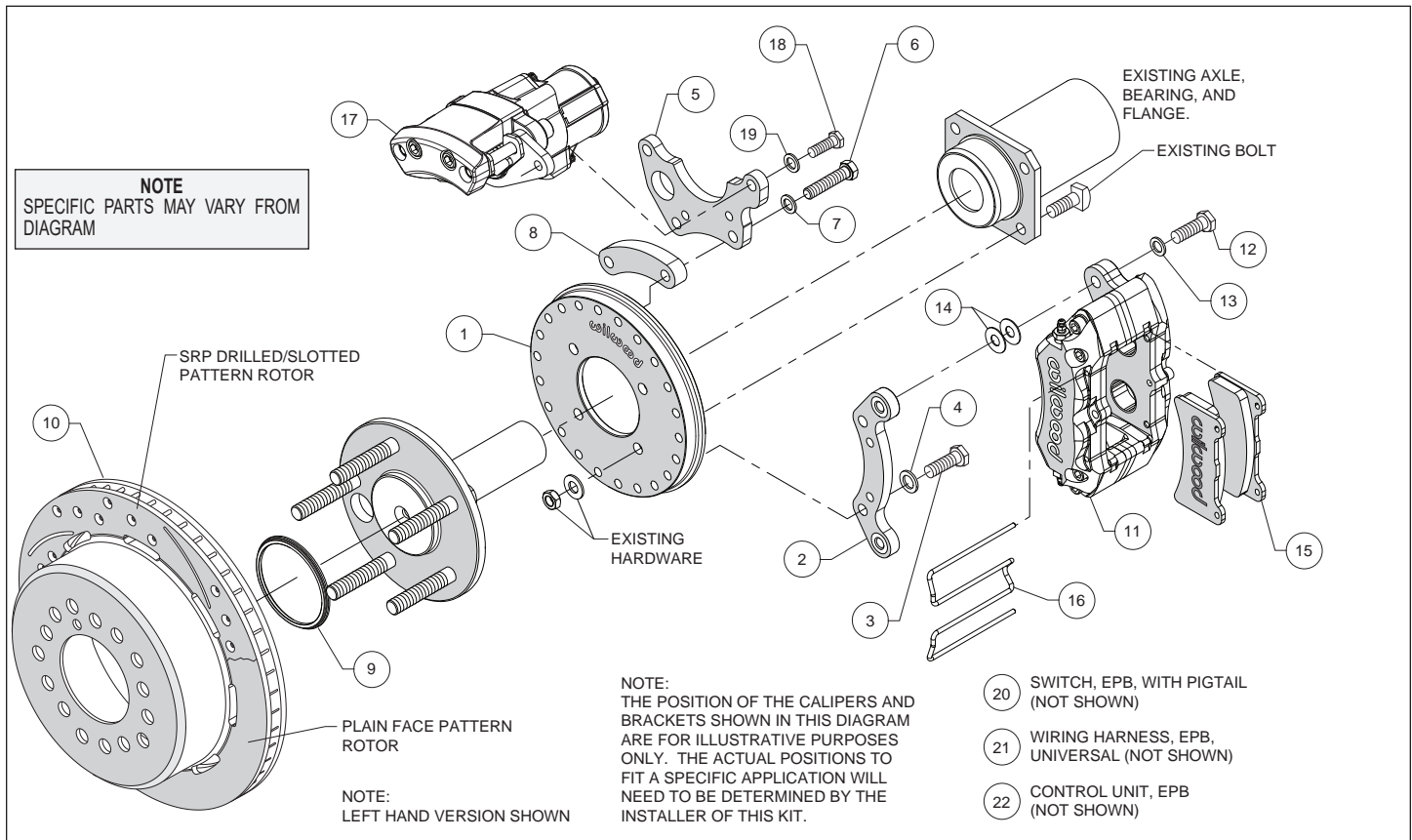

Figure 1. Typical Installation Configuration

Parts List

<u>ITEM NO.</u>	<u>PART NO.</u>	<u>DESCRIPTION</u>	<u>QTY</u>
1	250-16168	Backing Plate	2
2	250-15847	Bracket, Mounting, Service Caliper	2
3	230-10195	Bolt, 3/8-16 x 1.25 Long, Hex Head	4
4	240-10190	Washer, .391 I.D. x .625 O.D. x .063 Thick	4
5	250-15849	Bracket, Mounting, EPB Caliper	2
6	230-10331	Bolt, 3/8-16 x 1.75 Long, Hex Head	4
7	240-10190	Washer, .391 I.D. x .625 O.D. x .063 Thick	4
8	300-16065	Spacer, .525 Long	2
9	300-11337	Adapter, Rotor Registration	2
10	160-11365	Rotor, ULHP, .81" x 11.00" Dia.	2
11	120-16190-BK	Caliper, Forged DynaPro, Low-Profile, Black	2
12	230-10025	Bolt, 3/8-24 x 1.25 Long, Hex Head	4
13	240-10190	Washer, .391 I.D. x .625 O.D. x .063 Thick	4
14	240-1159	Shim, .035 Thick	16
15	150-11363K	Pad, BP-10 Compound, Axle Set	1
16	300-9636	Pad Clip Retainer	2
17	120-15700/01-BK	Caliper, EPB, Black (right and left hand)	2
18	230-15836	Bolt, 3/8-24 x .875 Long, Hex Head	4
19	240-10190	Washer, .391 I.D. x .625 O.D. x .063 Thick	4
20	300-15936	Switch, EPB, with Pigtail (not shown)	1
21	610-15588	EPB Wiring Harness, Universal (not shown)	1
22	620-15487	EPB Control Unit (not shown)	1