



# FORGED BILLET DYNALITE CALIPER

## Caliper Highlights:

The Dynalite caliper series has widespread application over many forms of motorsports. The **Forged Billet Dynalite** is the latest innovation from Wilwood providing substantial improvements in strength and performance over all comparable caliper models.

**Forged Dynalites** are the strongest calipers in the class. The process of stress-flow forging re-aligns the metal's grain structure within the contour of the caliper body. This process eliminates the breaks and interruptions to the internal grain structure that occur when machining a straight block billet. The FEA generated radial transition design eliminates steps and shoulders in the area between the piston housing body and the caliper bridges. Incorporating a radius in this transition area substantially increases resistance to deflection and caliper separation under load.

Structural deflection and volume displacement tests have proven the **Forged Dynalite** to outperform all existing styles of this popular caliper size. Without even considering the overall greater strength and reliability of the forging, the reduced deflection tendencies and the resulting decrease in fluid volume displacement translate to increased clamping efficiency with less pedal travel. The bottom line is a taller pedal and better stopping power.

The superior strength of this innovative design is combined with proven performance features from Wilwood's earlier designs. Each caliper is equipped with Wilwood's SRS stainless steel bridge plates. The SRS plates eliminate the bridge wear caused by pad gouging and extend the service life of the caliper body. The spring-loading action of the SRS plates also eliminates pad rattle and dampens the vibration harmonics that contribute to squeal under braking. Other standard Wilwood features include high temperature seals and stainless steel pistons to eliminate corrosion and retard heat transfer from the pads. Internal fluid passages eliminate the need for external tubes. Four corner bleed screws assure simple and effective air evacuation from the system and allow one caliper to be mounted in any front, rear, right or left position. Standard race calipers feature Wilwood's signature bright black anodized finish to resist corrosion and maintain their high tech style. Polished calipers (shown above) are also available for custom show car applications.

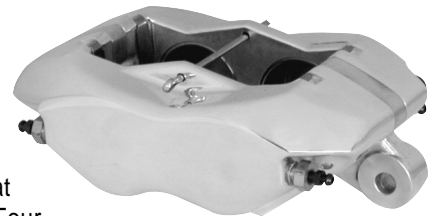

**Forged Dynalite** calipers are a direct replacement for all Wilwood Dynalite and similar competitive brand calipers with 5.25" centered mounting tabs. The **Forged Dynalite** uses the same 7112 type brake pad used in all earlier versions of this caliper. The full range of PolyMatrix pad compounds is available to match brake response and heat range to any application.

## ORDERING INFORMATION:

BORE SIZE		DISC WIDTH		BLACK PART NUMBER	POLISHED PART NUMBER
1.75"	44,5 mm	1.25"	31,8 mm	120-6814	—
1.75"	44,5 mm	1.00"	25,4 mm	120-6815	—
1.75"	44,5 mm	.81"	20,6 mm	120-6816	—
1.75"	44,5 mm	.50"	12,7 mm	120-6817	—
1.75"	44,5 mm	.38"	9,7 mm	120-6818	—
1.62"	41,1 mm	1.25"	31,8 mm	120-6809	120-6794-P
1.62"	41,1 mm	1.00"	25,4 mm	120-6810	120-6795-P
1.62"	41,1 mm	.81"	20,6 mm	120-6811	120-6796-P
1.62"	41,1 mm	.50"	12,7 mm	120-6812	120-6797-P
1.62"	41,1 mm	.38"	9,7 mm	120-6813	120-6798-P
1.38"	35,1 mm	1.25"	31,8 mm	120-6804	120-6789-P
1.38"	35,1 mm	1.00"	25,4 mm	120-6805	120-6790-P
1.38"	35,1 mm	.81"	20,6 mm	120-6806	120-6791-P
1.38"	35,1 mm	.50"	12,7 mm	120-6807	120-6792-P
1.38"	35,1 mm	.38"	9,7 mm	120-6808	120-6793-P

**FORGED DYNALITE CALIPER, MOUNTING DIMENSIONS:**

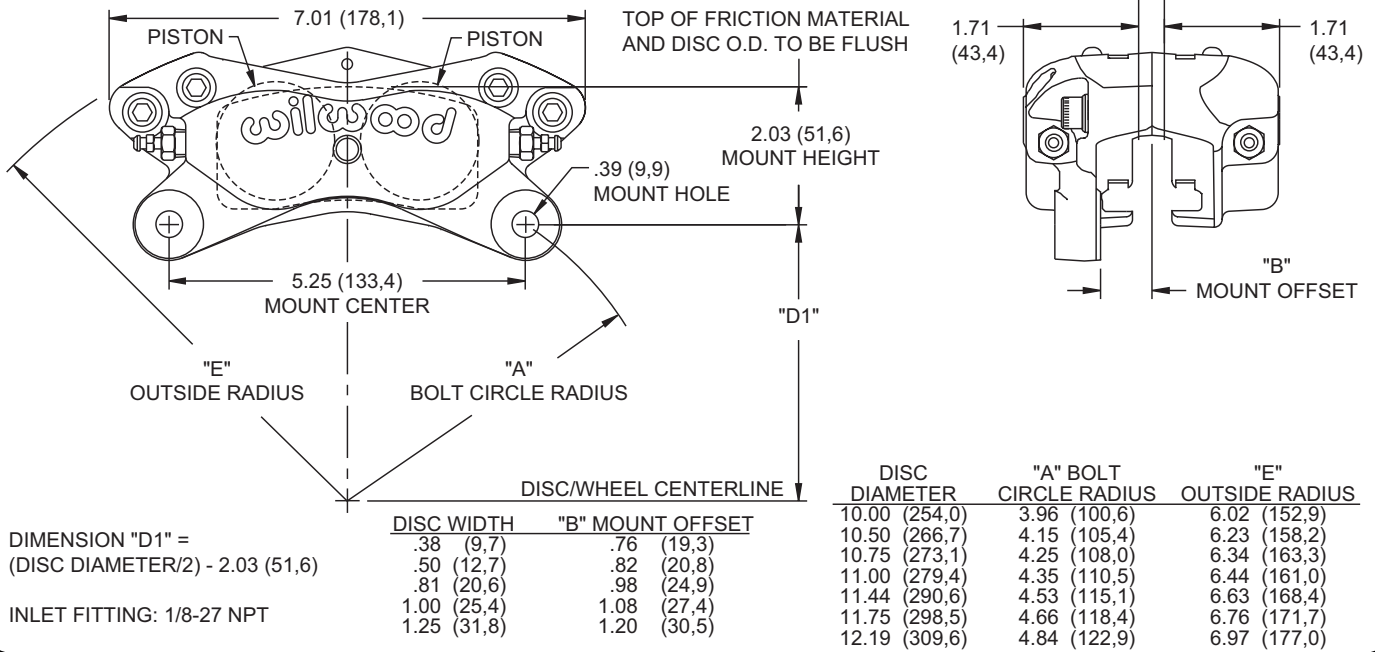

**DYNALITE CALIPER, TYPE 7112 PAD DIMENSIONS AND ORDERING INFORMATION:**

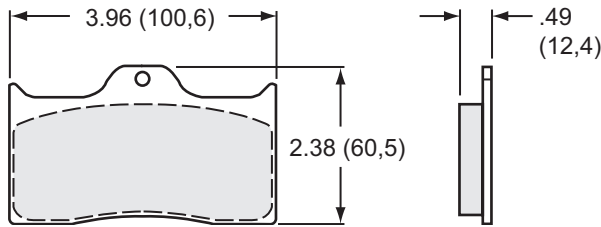

AXLE SET PART NO.	PAD TYPE/COMPOUND
15A - 5734K	7112 A PolyMatrix
15B - 3991K	7112 B PolyMatrix
15C - 4415K	7112 C PolyMatrix
15E - 6096K	7112 E PolyMatrix
15H - 8291K	7112 H PolyMatrix
15J - 7222K	7112 J PolyMatrix
15Q - 6824K	7112 Q PolyMatrix
15T - 5911K	7112 T PolyMatrix
150 - 2391K	Gator Pad

**ORDERING INFORMATION, USER SERVICEABLE COMPONENTS:**

CALIPER PART NO.	PISTON	SQ RING KIT (4 PK)	BLEED SCREW KIT (4 PK)	BODY SEAL (EA)	BRIDGE WEAR PLATE (EA)	COTTER PIN (10 PK)
120-6789-P	200-7518 (1.38")	130-2658	220-0627	210-2582	300-5875	180-0056
120-6790-P	200-7518 (1.38")	130-2658	220-0627	210-2582	300-5875	180-0056
120-6791-P	200-7518 (1.38")	130-2658	220-0627	210-2582	300-5875	180-0055
120-6792-P	200-7518 (1.38")	130-2658	220-0627	210-2582	300-5875	180-0055
120-6793-P	200-7518 (1.38")	130-2658	220-0627	210-2582	300-5875	180-0054
120-6794-P	200-7520 (1.62")	130-4346	220-0627	210-2582	300-5875	180-0056
120-6795-P	200-7520 (1.62")	130-4346	220-0627	210-2582	300-5875	180-0056
120-6796-P	200-7520 (1.62")	130-4346	220-0627	210-2582	300-5875	180-0055
120-6797-P	200-7520 (1.62")	130-4346	220-0627	210-2582	300-5875	180-0055
120-6798-P	200-7520 (1.62")	130-4346	220-0627	210-2582	300-5875	180-0054
120-6804	200-7518 (1.38")	130-2658	220-0627	210-2582	300-5875	180-0056
120-6805	200-7518 (1.38")	130-2658	220-0627	210-2582	300-5875	180-0056
120-6806	200-7518 (1.38")	130-2658	220-0627	210-2582	300-5875	180-0055
120-6807	200-7518 (1.38")	130-2658	220-0627	210-2582	300-5875	180-0055
120-6808	200-7518 (1.38")	130-2658	220-0627	210-2582	300-5875	180-0054
120-6809	200-7520 (1.62")	130-4346	220-0627	210-2582	300-5875	180-0056
120-6810	200-7520 (1.62")	130-4346	220-0627	210-2582	300-5875	180-0056
120-6811	200-7520 (1.62")	130-4346	220-0627	210-2582	300-5875	180-0055
120-6812	200-7520 (1.62")	130-4346	220-0627	210-2582	300-5875	180-0055
120-6813	200-7520 (1.62")	130-4346	220-0627	210-2582	300-5875	180-0054
120-6814	200-7528 (1.75")	130-2655	220-0627	210-2582	300-5875	180-0056
120-6815	200-7528 (1.75")	130-2655	220-0627	210-2582	300-5875	180-0056
120-6816	200-7528 (1.75")	130-2655	220-0627	210-2582	300-5875	180-0055
120-6817	200-7528 (1.75")	130-2655	220-0627	210-2582	300-5875	180-0055
120-6818	200-7528 (1.75")	130-2655	220-0627	210-2582	300-5875	180-0054